

SimElectronics[®] 1 Reference

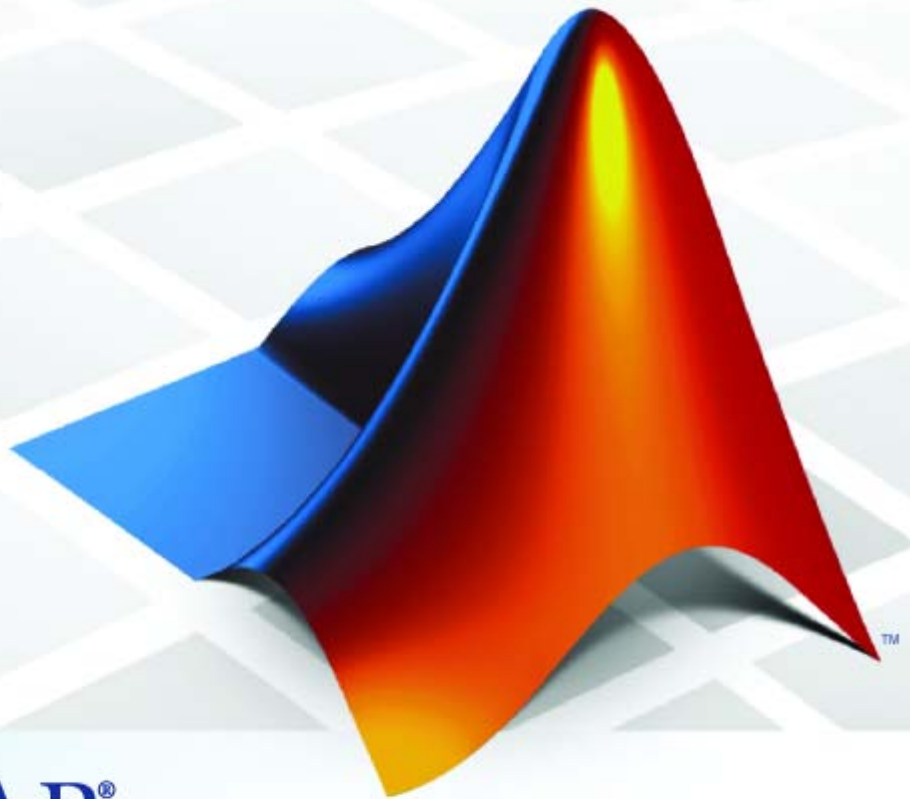

MATLAB[®]
& SIMULINK[®]

How to Contact The MathWorks



www.mathworks.com Web
comp.soft-sys.matlab Newsgroup
www.mathworks.com/contact_TS.html Technical Support



suggest@mathworks.com Product enhancement suggestions
bugs@mathworks.com Bug reports
doc@mathworks.com Documentation error reports
service@mathworks.com Order status, license renewals, passcodes
info@mathworks.com Sales, pricing, and general information



508-647-7000 (Phone)



508-647-7001 (Fax)



The MathWorks, Inc.
3 Apple Hill Drive
Natick, MA 01760-2098

For contact information about worldwide offices, see the MathWorks Web site.

SimElectronics[®] Reference

© COPYRIGHT 2008–2009 by The MathWorks, Inc.

The software described in this document is furnished under a license agreement. The software may be used or copied only under the terms of the license agreement. No part of this manual may be photocopied or reproduced in any form without prior written consent from The MathWorks, Inc.

FEDERAL ACQUISITION: This provision applies to all acquisitions of the Program and Documentation by, for, or through the federal government of the United States. By accepting delivery of the Program or Documentation, the government hereby agrees that this software or documentation qualifies as commercial computer software or commercial computer software documentation as such terms are used or defined in FAR 12.212, DFARS Part 227.72, and DFARS 252.227-7014. Accordingly, the terms and conditions of this Agreement and only those rights specified in this Agreement, shall pertain to and govern the use, modification, reproduction, release, performance, display, and disclosure of the Program and Documentation by the federal government (or other entity acquiring for or through the federal government) and shall supersede any conflicting contractual terms or conditions. If this License fails to meet the government's needs or is inconsistent in any respect with federal procurement law, the government agrees to return the Program and Documentation, unused, to The MathWorks, Inc.

Trademarks

MATLAB and Simulink are registered trademarks of The MathWorks, Inc. See www.mathworks.com/trademarks for a list of additional trademarks. Other product or brand names may be trademarks or registered trademarks of their respective holders.

Patents

The MathWorks products are protected by one or more U.S. patents. Please see www.mathworks.com/patents for more information.

Revision History

April 2008	Online only	New for Version 1.0 (Release 2008a+)
October 2008	Online only	Revised for Version 1.1 (Release 2008b)
March 2009	Online only	Revised for Version 1.2 (Release 2009a)
September 2009	Online only	Revised for Version 1.3 (Release 2009b)

Block Reference

1

Actuators & Drivers	1-2
Integrated Circuits	1-3
Logic	1-3
Passive Devices	1-4
Semiconductor Devices	1-4
Sensors	1-5
Sources	1-5
SPICE-Compatible Sources	1-6
SPICE-Compatible Semiconductors	1-7
Utilities	1-8

Blocks — Alphabetical List

2

Functions — Alphabetical List

3

Index

Block Reference

Actuators & Drivers (p. 1-2)	Mechanical control and motor devices
Integrated Circuits (p. 1-3)	Electronic circuits
Logic (p. 1-3)	Logic gates
Passive Devices (p. 1-4)	Passive electrical devices
Semiconductor Devices (p. 1-4)	Circuit components made from semiconductor material
Sensors (p. 1-5)	Electromechanical sensors
Sources (p. 1-5)	Electrical supplies
SPICE-Compatible Sources (p. 1-6)	SPICE-compatible electrical supplies
SPICE-Compatible Semiconductors (p. 1-7)	SPICE-compatible circuit components made from semiconductor material
Utilities (p. 1-8)	System-level parameter specification

Actuators & Drivers

Controlled PWM Voltage	Model pulse-width modulated voltage source
DC Motor	Model electrical and torque characteristics of DC motor
Generic Linear Actuator	Model generic linear actuator driven from DC voltage source or PWM driver
Generic Rotary Actuator	Model generic rotary actuator driven from DC voltage source or PWM driver
H-Bridge	Model H-bridge motor driver
Induction Motor	Model induction motor powered by ideal AC supply
Piezo Linear Motor	Model force-speed characteristics of linear piezoelectric traveling wave motor
Piezo Rotary Motor	Model torque-speed characteristics of rotary piezoelectric traveling wave motor
Piezo Stack	Model electrical and force characteristics of piezoelectric stacked actuator
Servomotor	Model brushless motor with closed-loop torque control
Shunt Motor	Model electrical and torque characteristics of shunt motor
Solenoid	Model electrical characteristics and generated force of solenoid
Stepper Motor	Model stepper motor

Stepper Motor Driver

Model stepper motor driver

Universal Motor

Model electrical and torque characteristics of a universal (or series) motor

Integrated Circuits

Band-Limited Op-Amp

Model band-limited operational amplifier

Comparator

Model a comparator behaviorally

Finite-Gain Op-Amp

Model gain-limited operational amplifier

Timer

Model timer integrated circuit behaviorally

Logic

CMOS AND

Model CMOS AND gate behaviorally

CMOS Buffer

Model CMOS Buffer gate behaviorally

CMOS NAND

Model CMOS NAND gate behaviorally

CMOS NOR

Model CMOS NOR gate behaviorally

CMOS NOT

Model CMOS NOT gate behaviorally

CMOS OR

Model CMOS OR gate behaviorally

CMOS XOR

Model CMOS XOR gate behaviorally

S-R Latch

Model an S-R Latch behaviorally

Passive Devices

Crystal	Model stable resonator
Current-Controlled Switch	Model current-controlled switch with hysteresis
Fuse	Model fuse that protects against excessive current
Relay	Model switching and associated delay of relay
Resistor	Model SPICE-compatible resistor
Thermal Resistor	Model resistor with thermal port
Three-Winding Mutual Inductor	Model three coupled inductors
Variable Capacitor	Model linear time-varying capacitor
Variable Inductor	Model linear time-varying inductor
Voltage-Controlled Switch	Model voltage-controlled switch with hysteresis

Semiconductor Devices

Diode	Model piecewise linear, piecewise linear zener, or exponential diode
N-Channel IGBT	Model N-Channel IGBT
N-Channel JFET	Model N-Channel JFET
N-Channel MOSFET	Model N-Channel MOSFET using Shichman-Hodges equation
NPN Bipolar Transistor	Model NPN bipolar transistor using enhanced Ebers-Moll equations
Optocoupler	Model optocoupler as LED, current sensor, and controlled current source
P-Channel JFET	Model P-Channel JFET

P-Channel MOSFET	Model P-Channel MOSFET using Shichman-Hodges equation
PNP Bipolar Transistor	Model PNP bipolar transistor using enhanced Ebers-Moll equations

Sensors

Incremental Shaft Encoder	Model device that converts information about angular shaft position into electrical pulses
Light-Emitting Diode	Model light-emitting diode as exponential diode and current sensor in series
Photodiode	Model photodiode as parallel controlled current source and exponential diode
Proximity Sensor	Model simple distance sensor
PS Sensor	Model generic linear sensor
Strain Gauge	Model deformation sensor
Thermistor	Model NTC thermistor using B-parameter equation
Thermocouple	Model sensor that converts thermal potential difference into electrical potential difference

Sources

Generic Battery	Model simple battery
Negative Supply Rail	Model ideal negative supply rail

Positive Supply Rail

Model ideal positive supply rail

Solar Cell

Model single solar cell

SPICE-Compatible Sources

DC Current Source

Model constant current source

DC Voltage Source

Model constant voltage source

Exponential Current Source

Model exponential pulse current source

Exponential Voltage Source

Model exponential pulse voltage source

PCCCS

Model polynomial current-controlled current source

PCCCS2

Model polynomial current-controlled current source with two controlling inputs

PCCVS

Model polynomial current-controlled voltage source

PCCVS2

Model polynomial current-controlled voltage source with two controlling inputs

Pulse Current Source

Model periodic square pulse current source

Pulse Voltage Source

Model periodic square pulse voltage source

PVCCS

Model polynomial voltage-controlled current source

PVCCS2

Model polynomial voltage-controlled current source with two controlling inputs

PVCVS	Model polynomial voltage-controlled voltage source
PVCVS2	Model polynomial voltage-controlled voltage source with two controlling inputs
PWL Current Source	Model lookup table current source
PWL Voltage Source	Model lookup table voltage source
SFFM Current Source	Model single-frequency FM current source
SFFM Voltage Source	Model single-frequency FM voltage source
Sinusoidal Current Source	Model damped sinusoidal current source
Sinusoidal Voltage Source	Model damped sinusoidal voltage source

SPICE-Compatible Semiconductors

Diode (SPICE)	Model SPICE-compatible diode
NJFET	Model SPICE-compatible N-Channel JFET
NMOS	Model SPICE-compatible N-Channel MOSFET
NPN	Model Gummel-Poon NPN Transistor
PJFET	Model SPICE-compatible P-Channel JFET
PMOS	Model SPICE-compatible P-Channel MOSFET
PNP	Model Gummel-Poon PNP Transistor

Utilities

SPICE Environment Parameters

Set parameters that apply to all connected SPICE-compatible blocks

Blocks — Alphabetical List

Band-Limited Op-Amp

Purpose Model band-limited operational amplifier

Library Integrated Circuits

Description



Band-Limited Op-Amp

The Band-Limited Op-Amp block models a band-limited operational amplifier. If the voltages at the positive and negative ports are V_p and V_m , respectively, the output voltage is:

$$V_{out} = \frac{A(V_p - V_m)}{\frac{s}{2\pi f} + 1} - I_{out} * R_{out}$$

where:

- A is the gain.
- R_{out} is the output resistance.
- I_{out} is the output current.
- s is the Laplace operator.
- f is the 3-dB bandwidth.

The input current is:

$$\frac{V_p - V_m}{R_{in}}$$

where R_{in} is the input resistance.

The block does not use the initial condition you specify using the **Initial output voltage, V0** parameter if you select the **Start simulation from steady state** check box in the Simscape™ Solver Configuration block.

Dialog Box and Parameters

Block Parameters: Band-Limited Op-Amp

Band-Limited Op-Amp

This block models a band-limited op-amp. If the voltages at the positive and negative pins are denoted V_p and V_m , then the output voltage is given by

$$V_{out} = A \cdot (V_p - V_m) \cdot \frac{1}{s / (2 \cdot \pi \cdot f) + 1} - I_{out} \cdot R_{out}$$

where A is the gain, R_{out} is the output resistance, I_{out} is the output current, s is the Laplace operator, and f is the 3dB bandwidth. The input current is given by $(V_p - V_m) / R_{in}$ where R_{in} is the input resistance. The no-load output voltage is limited the range V_{min} to V_{max} , and the slew rate is limited to $\pm V_{dot}$.

The Initial output voltage, V_0 , sets the initial op-amp output voltage. Note that this does not take account of any voltage drop across R_{out} . The initial condition is not used if you select the Start simulation from steady state option in the Solver Configuration block.

Parameters

Gain, A:	1000	
Input resistance, R_{in} :	1e+06	Ohm
Output resistance, R_{out} :	100	Ohm
Minimum output, V_{min} :	-15	V
Maximum output, V_{max} :	15	V
Maximum slew rate, V_{dot} :	1000	V/s
Bandwidth, f :	1e+05	Hz
Initial output voltage, V_0 :	0	V

OK Cancel Help Apply

Gain, A

The open-loop gain of the operational amplifier. The default value is 1000.

Band-Limited Op-Amp

Input resistance, R_{in}

The resistance at the input of the operational amplifier that the block uses to calculate the input current. The default value is $1e+06 \Omega$.

Output resistance, R_{out}

The resistance at the output of the operational amplifier that the block uses to calculate the drop in output voltage due to the output current. The default value is 100Ω .

Minimum output, V_{min}

The lower limit on the operational amplifier no-load output voltage. The default value is -15 V .

Maximum output, V_{max}

The upper limit on the operational amplifier no-load output voltage. The default value is 15 V .

Maximum slew rate, V_{dot}

The maximum positive or negative rate of change of output voltage magnitude. The default value is 1000 V/s .

Bandwidth, f

The open-loop bandwidth, that is, the frequency at which the gain drops by 3 dB compared to the low-frequency gain, A . The default value is $1e+05 \text{ Hz}$.

Initial output voltage, V_0

The output voltage at the start of the simulation when the output current is zero. The default value is 0 V .

Note This parameter value does not account for the voltage drop across the output resistor.

Ports

The block has the following ports:

+

Positive electrical voltage.

- Negative electrical voltage.

OUT Output voltage.

See Also Simscape Op-Amp, Finite-Gain Op-Amp

CMOS AND

Purpose Model CMOS AND gate behaviorally

Library Logic

Description The CMOS AND block represents a CMOS AND logic gate behaviorally:

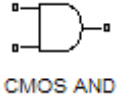

- The block output voltage value equals the **High level output voltage** parameter value if the logic levels of both of the gate inputs are 1.
- The block output voltage value equals the **Low level output voltage** parameter value otherwise.

The block determines the logic levels of the gate inputs as follows:

- If the gate voltage is greater than the threshold voltage, the block interprets the input as logic 1.
- Otherwise, the block interprets the input as logic 0.

The *threshold voltage* is the voltage value at midpoint between the **High level input voltage** parameter value and the **Low level input voltage** parameter value.

Note The block does not model the internal individual MOSFET devices that make up the gate.

The block models the gate as follows:

- The gate inputs have infinite resistance and finite or zero capacitance.
- The gate output (voltage source) drives a series resistor and capacitor connected to ground.
- The block sets the value of the gate output capacitor such that the resistor-capacitor time constant equals the **Propagation delay** parameter value.

Basic Assumptions and Limitations

The block does not model the internal individual MOSFET devices that make up the gate. This limitation has the following implications:

- The block does not accurately model the gate's response to input noise and inputs that are around the logic threshold voltage.
- The block does not accurately model dynamic response.
- The block's linear drop in output voltage as a function of output current is an approximation to the MOSFET output behavior.

To model a logic gate at the device level, use the `netlist2sl` function to import the netlist of the logic gate.

Dialog Box and Parameters

Inputs Tab

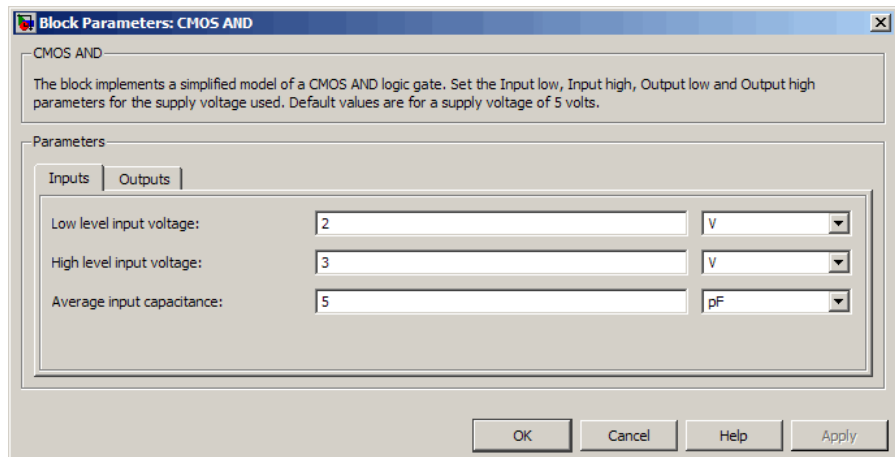

Low level input voltage

Voltage value below which the block interprets the input voltage as logic LOW. The default value is 2 V.

High level input voltage

Voltage value above which the block interprets the input voltage as logic HIGH. The default value is 3 V.

Average input capacitance

Fixed capacitance that approximates the input capacitance for a MOSFET gate. The MOSFET capacitance depends on the applied voltage. When you drive this block with another gate, the **Average input capacitance** produces a rise time similar to that of the MOSFET. You can usually find this capacitance value on a manufacturer datasheet. The default value is 5 pF. Setting this value to zero may result in faster simulation times.

Outputs Tab

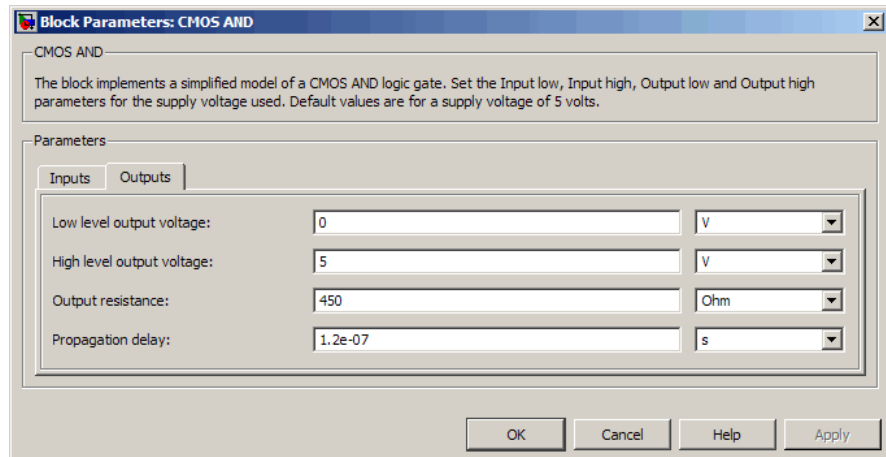

Low level output voltage

Voltage value at the output when the output logic level is LOW. The default value is 0 V.

High level output voltage

Voltage value at the output when the output logic level is HIGH. The default value is 5 V.

Output resistance

Value of the series output resistor that is used to model the drop in output voltage resulting from the output current. The default value is 450 Ω . You can derive this value from a datasheet by

dividing the high-level output voltage by the maximum low-level output current.

Propagation delay

Time it takes for the output to swing from LOW to HIGH or HIGH to LOW after the input logic levels change. The default value is $1.2e-07$ s.

Ports

The block has the following ports:

- A Electrical input port.
- B Electrical input port.
- J Electrical output port.

CMOS Buffer

Purpose Model CMOS Buffer gate behaviorally

Library Logic

Description

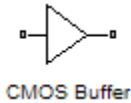

The CMOS Buffer block represents a CMOS Buffer logic gate behaviorally:

- The block output voltage value equals the **High level output voltage** parameter value if the logic level of the gate input is 1.
- The block output voltage value equals the **Low level output voltage** parameter value otherwise.

The block determines the logic level of the gate input as follows:

- If the gate voltage is greater than the threshold voltage, the block interprets the input as logic 1.
- Otherwise, the block interprets the input as logic 0.

The *threshold voltage* is the voltage value at midpoint between the **High level input voltage** parameter value and the **Low level input voltage** parameter value.

Note The block does not model the internal individual MOSFET devices that make up the gate.

The block models the gate as follows:

- The gate input has infinite resistance and finite or zero capacitance.
- The gate output (voltage source) drives a series resistor and capacitor connected to ground.
- The block sets the value of the gate output capacitor such that the resistor-capacitor time constant equals the **Propagation delay** parameter value.

Basic Assumptions and Limitations

The block does not model the internal individual MOSFET devices that make up the gate. This limitation has the following implications:

- The block does not accurately model the gate's response to input noise and inputs that are around the logic threshold voltage.
- The block does not accurately model dynamic response.
- The block's linear drop in output voltage as a function of output current is an approximation to the MOSFET output behavior.

To model a logic gate at the device level, use the `netlist2sl` function to import the netlist of the logic gate.

Dialog Box and Parameters

Inputs Tab

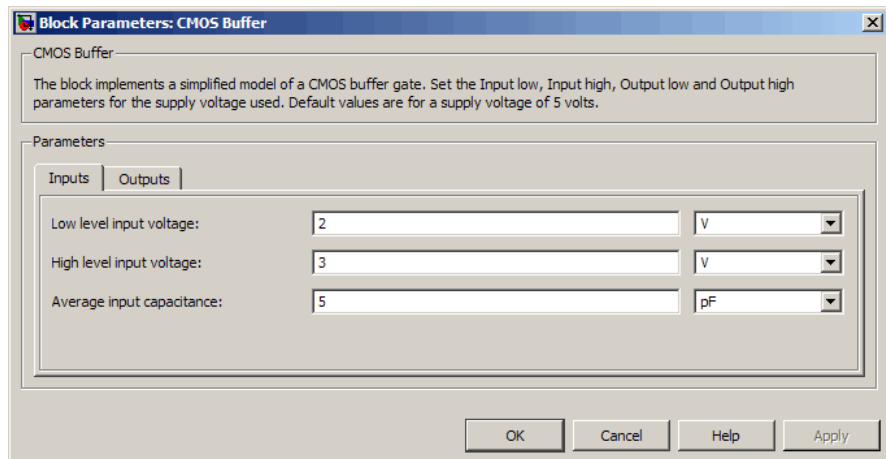

Low level input voltage

Voltage value below which the block interprets the input voltage as logic LOW. The default value is 2 V.

High level input voltage

Voltage value above which the block interprets the input voltage as logic HIGH. The default value is 3 V.

CMOS Buffer

Average input capacitance

Fixed capacitance that approximates the input capacitance for a MOSFET gate. The MOSFET capacitance depends on the applied voltage. When you drive this block with another gate, the **Average input capacitance** produces a rise time similar to that of the MOSFET. You can usually find this capacitance value on a manufacturer datasheet. The default value is 5 pF. Setting this value to zero may result in faster simulation times.

Outputs Tab

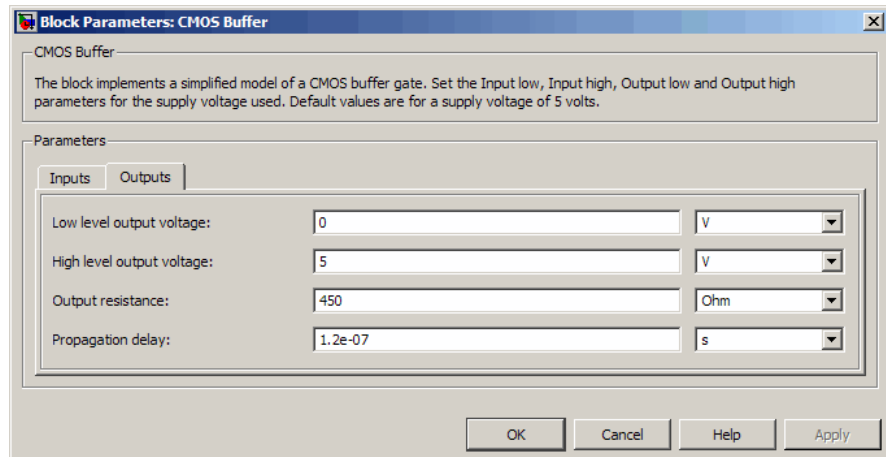

Low level output voltage

Voltage value at the output when the output logic level is LOW. The default value is 0 V.

High level output voltage

Voltage value at the output when the output logic level is HIGH. The default value is 5 V.

Output resistance

Value of the series output resistor that is used to model the drop in output voltage resulting from the output current. The default value is 450 Ω . You can derive this value from a datasheet by

dividing the high-level output voltage by the maximum low-level output current.

Propagation delay

Time it takes for the output to swing from LOW to HIGH or HIGH to LOW after the input logic levels change. The default value is $1.2e-07$ s.

Ports

The block has the following ports:

- A
Electrical input port.
- J
Electrical output port.

CMOS NAND

Purpose Model CMOS NAND gate behaviorally

Library Logic

Description The CMOS NAND block represents a CMOS NAND logic gate behaviorally:

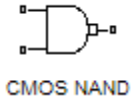

- The block output voltage value equals the **High level output voltage** parameter value if the logic levels of both of the gate inputs are 0.
- The block output voltage value equals the **Low level output voltage** parameter value otherwise.

The block determines the logic levels of the gate inputs as follows:

- If the gate voltage is greater than the threshold voltage, the block interprets the input as logic 1.
- Otherwise, the block interprets the input as logic 0.

The *threshold voltage* is the voltage value at midpoint between the **High level input voltage** parameter value and the **Low level input voltage** parameter value.

Note The block does not model the internal individual MOSFET devices that make up the gate.

The block models the gate as follows:

- The gate inputs have infinite resistance and finite or zero capacitance.
- The gate output (voltage source) drives a series resistor and capacitor connected to ground.

- The block sets the value of the gate output capacitor such that the resistor-capacitor time constant equals the **Propagation delay** parameter value.

Basic Assumptions and Limitations

The block does not model the internal individual MOSFET devices that make up the gate. This limitation has the following implications:

- The block does not accurately model the gate's response to input noise and inputs that are around the logic threshold voltage.
- The block does not accurately model dynamic response.
- The block's linear drop in output voltage as a function of output current is an approximation to the MOSFET output behavior.

To model a logic gate at the device level, use the `netlist2sl` function to import the netlist of the logic gate.

Dialog Box and Parameters

Inputs Tab

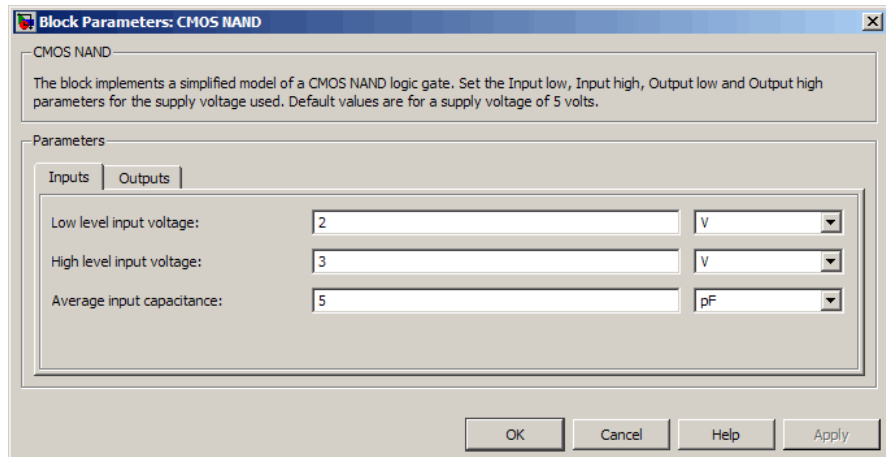

CMOS NAND

Low level input voltage

Voltage value below which the block interprets the input voltage as logic LOW. The default value is 2 V.

High level input voltage

Voltage value above which the block interprets the input voltage as logic HIGH. The default value is 3 V.

Average input capacitance

Fixed capacitance that approximates the input capacitance for a MOSFET gate. The MOSFET capacitance depends on the applied voltage. When you drive this block with another gate, the **Average input capacitance** produces a rise time similar to that of the MOSFET. You can usually find this capacitance value on a manufacturer datasheet. The default value is 5 pF. Setting this value to zero may result in faster simulation times.

Outputs Tab

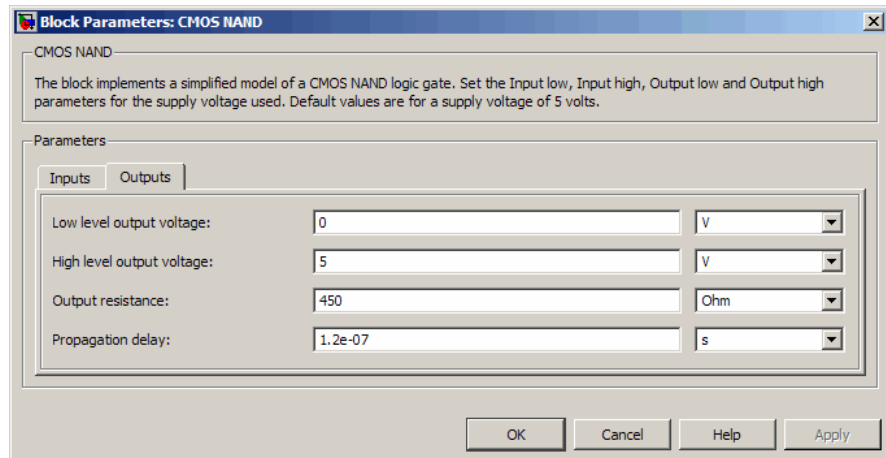

Low level output voltage

Voltage value at the output when the output logic level is LOW. The default value is 0 V.

High level output voltage

Voltage value at the output when the output logic level is HIGH. The default value is 5 V.

Output resistance

Value of the series output resistor that is used to model the drop in output voltage resulting from the output current. The default value is 450 Ω . You can derive this value from a datasheet by dividing the high-level output voltage by the maximum low-level output current.

Propagation delay

Time it takes for the output to swing from LOW to HIGH or HIGH to LOW after the input logic levels change. The default value is 1.2e-07 s.

Ports

The block has the following ports:

- A Electrical input port.
- B Electrical input port.
- J Electrical output port.

CMOS NOR

Purpose Model CMOS NOR gate behaviorally

Library Logic

Description The CMOS NOR block represents a CMOS NOR logic gate behaviorally:

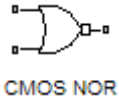

- The block output voltage value equals the **Low level output voltage** parameter value if the logic levels of any of the gate inputs are 1.
- The block output voltage value equals the **High level output voltage** parameter value otherwise.

The block determines the logic levels of the gate inputs as follows:

- If the gate voltage is greater than the threshold voltage, the block interprets the input as logic 1.
- Otherwise, the block interprets the input as logic 0.

The *threshold voltage* is the voltage value at midpoint between the **High level input voltage** parameter value and the **Low level input voltage** parameter value.

Note The block does not model the internal individual MOSFET devices that make up the gate.

The block models the gate as follows:

- The gate inputs have infinite resistance and finite or zero capacitance.
- The gate output (voltage source) drives a series resistor and capacitor connected to ground.
- The block sets the value of the gate output capacitor such that the resistor-capacitor time constant equals the **Propagation delay** parameter value.

Basic Assumptions and Limitations

The block does not model the internal individual MOSFET devices that make up the gate. This limitation has the following implications:

- The block does not accurately model the gate's response to input noise and inputs that are around the logic threshold voltage.
- The block does not accurately model dynamic response.
- The block's linear drop in output voltage as a function of output current is an approximation to the MOSFET output behavior.

To model a logic gate at the device level, use the `netlist2sl` function to import the netlist of the logic gate.

Dialog Box and Parameters

Inputs Tab

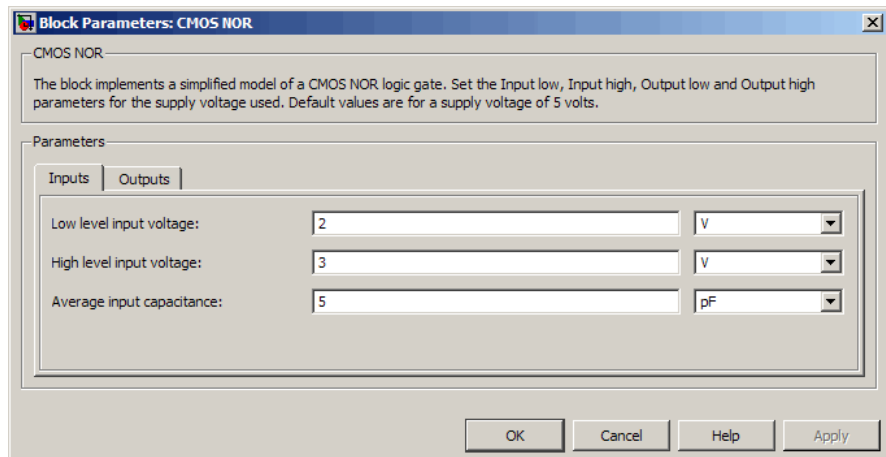

Low level input voltage

Voltage value below which the block interprets the input voltage as logic LOW. The default value is 2 V.

High level input voltage

Voltage value above which the block interprets the input voltage as logic HIGH. The default value is 3 V.

Average input capacitance

Fixed capacitance that approximates the input capacitance for a MOSFET gate. The MOSFET capacitance depends on the applied voltage. When you drive this block with another gate, the **Average input capacitance** produces a rise time similar to that of the MOSFET. You can usually find this capacitance value on a manufacturer datasheet. The default value is 5 pF. Setting this value to zero may result in faster simulation times.

Outputs Tab

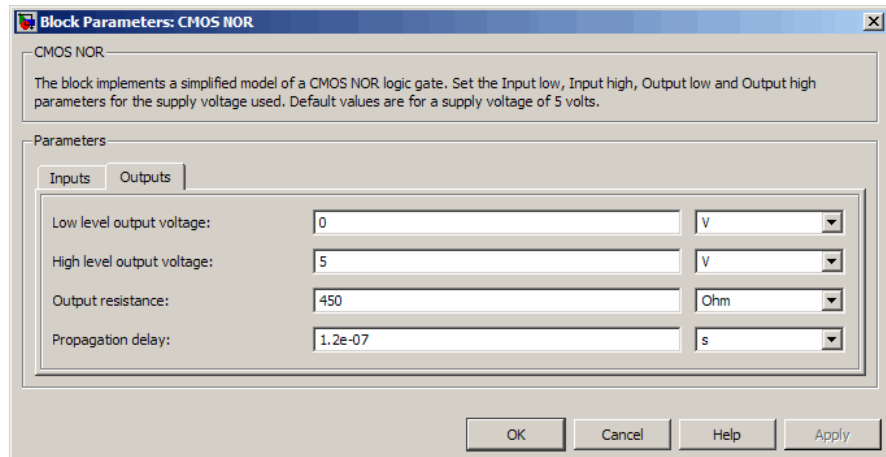

Low level output voltage

Voltage value at the output when the output logic level is LOW. The default value is 0 V.

High level output voltage

Voltage value at the output when the output logic level is HIGH. The default value is 5 V.

Output resistance

Value of the series output resistor that is used to model the drop in output voltage resulting from the output current. The default value is 450 Ω . You can derive this value from a datasheet by

dividing the high-level output voltage by the maximum low-level output current.

Propagation delay

Time it takes for the output to swing from LOW to HIGH or HIGH to LOW after the input logic levels change. The default value is $1.2e-07$ s.

Ports

The block has the following ports:

- A Electrical input port.
- B Electrical input port.
- J Electrical output port.

CMOS NOT

Purpose Model CMOS NOT gate behaviorally

Library Logic

Description The CMOS NOT block represents a CMOS NOT logic gate behaviorally:

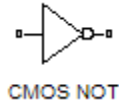

- The block output voltage value equals the **High level output voltage** parameter value if the logic level of the gate input is 0.
- The block output voltage value equals the **Low level output voltage** parameter value otherwise.

The block determines the logic level of the gate input as follows:

- If the gate voltage is greater than the threshold voltage, the block interprets the input as logic 1.
- Otherwise, the block interprets the input as logic 0.

The *threshold voltage* is the voltage value at midpoint between the **High level input voltage** parameter value and the **Low level input voltage** parameter value.

Note The block does not model the internal individual MOSFET devices that make up the gate.

The block models the gate as follows:

- The gate input has infinite resistance and finite or zero capacitance.
- The gate output (voltage source) drives a series resistor and capacitor connected to ground.
- The block sets the value of the gate output capacitor such that the resistor-capacitor time constant equals the **Propagation delay** parameter value.

Basic Assumptions and Limitations

The block does not model the internal individual MOSFET devices that make up the gate. This limitation has the following implications:

- The block does not accurately model the gate's response to input noise and inputs that are around the logic threshold voltage.
- The block does not accurately model dynamic response.
- The block's linear drop in output voltage as a function of output current is an approximation to the MOSFET output behavior.

To model a logic gate at the device level, use the `netlist2sl` function to import the netlist of the logic gate.

Dialog Box and Parameters

Inputs Tab

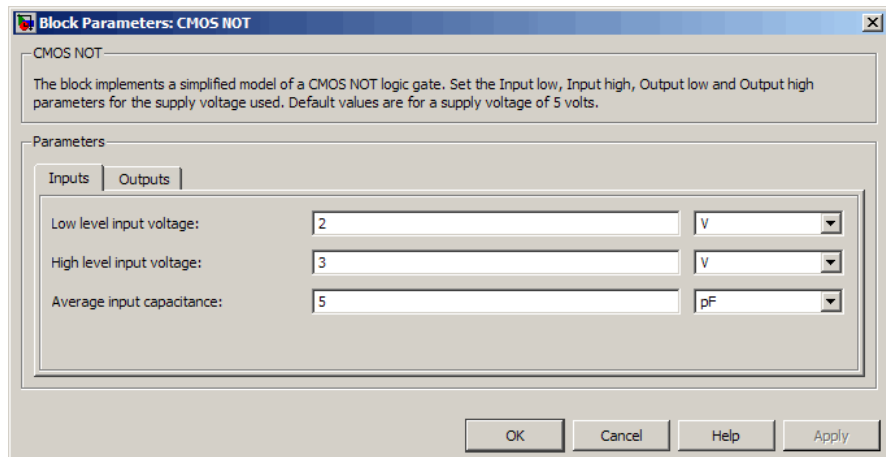

Low level input voltage

Voltage value below which the block interprets the input voltage as logic LOW. The default value is 2 V.

High level input voltage

Voltage value above which the block interprets the input voltage as logic HIGH. The default value is 3 V.

CMOS NOT

Average input capacitance

Fixed capacitance that approximates the input capacitance for a MOSFET gate. The MOSFET capacitance depends on the applied voltage. When you drive this block with another gate, the **Average input capacitance** produces a rise time similar to that of the MOSFET. You can usually find this capacitance value on a manufacturer datasheet. The default value is 5 pF. Setting this value to zero may result in faster simulation times.

Outputs Tab

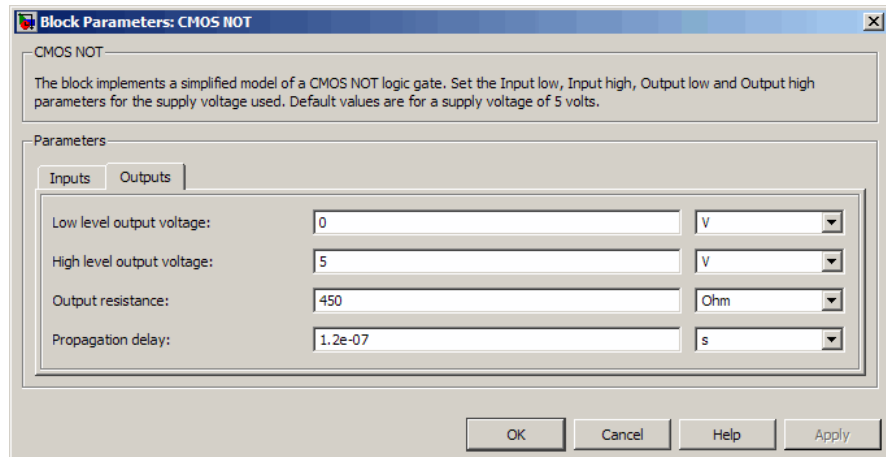

Low level output voltage

Voltage value at the output when the output logic level is LOW. The default value is 0 V.

High level output voltage

Voltage value at the output when the output logic level is HIGH. The default value is 5 V.

Output resistance

Value of the series output resistor that is used to model the drop in output voltage resulting from the output current. The default value is 450 Ω . You can derive this value from a datasheet by

dividing the high-level output voltage by the maximum low-level output current.

Propagation delay

Time it takes for the output to swing from LOW to HIGH or HIGH to LOW after the input logic levels change. The default value is $1.2e-07$ s.

Ports

The block has the following ports:

- A
Electrical input port.
- J
Electrical output port.

CMOS OR

Purpose Model CMOS OR gate behaviorally

Library Logic

Description The CMOS OR block represents a CMOS OR logic gate behaviorally:

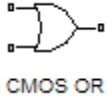

- The block output voltage value equals the **High level output voltage** parameter value if the logic levels of any of the gate inputs are 1.
- The block output voltage value equals the **Low level output voltage** parameter value otherwise.

The block determines the logic levels of the gate inputs as follows:

- If the gate voltage is greater than the threshold voltage, the block interprets the input as logic 1.
- Otherwise, the block interprets the input as logic 0.

The *threshold voltage* is the voltage value at midpoint between the **High level input voltage** parameter value and the **Low level input voltage** parameter value.

Note The block does not model the internal individual MOSFET devices that make up the gate.

The block models the gate as follows:

- The gate inputs have infinite resistance and finite or zero capacitance.
- The gate output (voltage source) drives a series resistor and capacitor connected to ground.
- The block sets the value of the gate output capacitor such that the resistor-capacitor time constant equals the **Propagation delay** parameter value.

Basic Assumptions and Limitations

The block does not model the internal individual MOSFET devices that make up the gate. This limitation has the following implications:

- The block does not accurately model the gate's response to input noise and inputs that are around the logic threshold voltage.
- The block does not accurately model dynamic response.
- The block's linear drop in output voltage as a function of output current is an approximation to the MOSFET output behavior.

To model a logic gate at the device level, use the `netlist2sl` function to import the netlist of the logic gate.

Dialog Box and Parameters

Inputs Tab

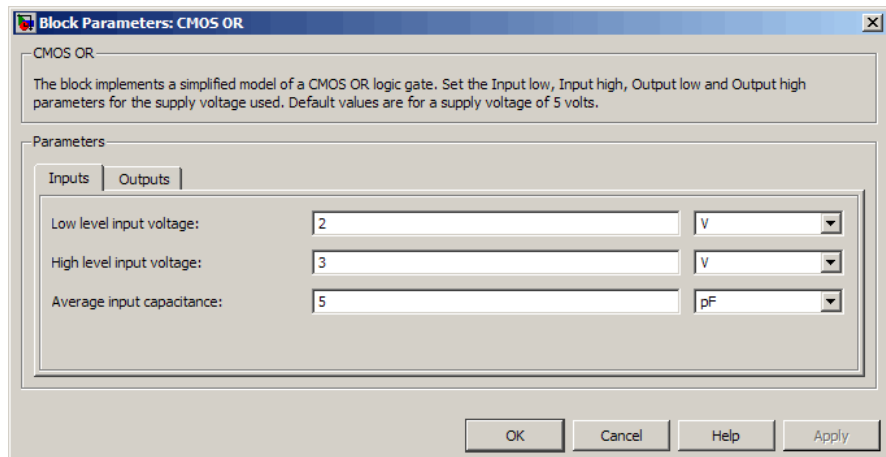

Low level input voltage

Voltage value below which the block interprets the input voltage as logic LOW. The default value is 2 V.

High level input voltage

Voltage value above which the block interprets the input voltage as logic HIGH. The default value is 3 V.

Average input capacitance

Fixed capacitance that approximates the input capacitance for a MOSFET gate. The MOSFET capacitance depends on the applied voltage. When you drive this block with another gate, the **Average input capacitance** produces a rise time similar to that of the MOSFET. You can usually find this capacitance value on a manufacturer datasheet. The default value is 5 pF. Setting this value to zero may result in faster simulation times.

Outputs Tab

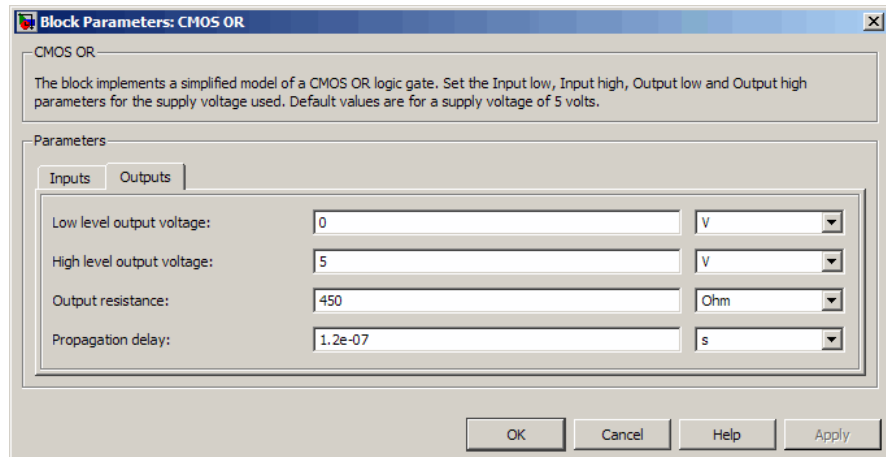

Low level output voltage

Voltage value at the output when the output logic level is LOW. The default value is 0 V.

High level output voltage

Voltage value at the output when the output logic level is HIGH. The default value is 5 V.

Output resistance

Value of the series output resistor that is used to model the drop in output voltage resulting from the output current. The default value is 450 Ω . You can derive this value from a datasheet by

dividing the high-level output voltage by the maximum low-level output current.

Propagation delay

Time it takes for the output to swing from LOW to HIGH or HIGH to LOW after the input logic levels change. The default value is $1.2e-07$ s.

Ports

The block has the following ports:

- A Electrical input port.
- B Electrical input port.
- J Electrical output port.

CMOS XOR

Purpose Model CMOS XOR gate behaviorally

Library Logic

Description The CMOS XOR block represents a CMOS XOR logic gate behaviorally:



CMOS XOR

- The block output voltage value equals the **High level output voltage** parameter value if the logic level of exactly one of the gate inputs is 1.
- The block output voltage value equals the **Low level output voltage** parameter value otherwise.

The block determines the logic levels of the gate inputs as follows:

- If the gate voltage is greater than the threshold voltage, the block interprets the input as logic 1.
- Otherwise, the block interprets the input as logic 0.

The *threshold voltage* is the voltage value at midpoint between the **High level input voltage** parameter value and the **Low level input voltage** parameter value.

Note The block does not model the internal individual MOSFET devices that make up the gate.

The block models the gate as follows:

- The gate inputs have infinite resistance and finite or zero capacitance.
- The gate output (voltage source) drives a series resistor and capacitor connected to ground.
- The block sets the value of the gate output capacitor such that the resistor-capacitor time constant equals the **Propagation delay** parameter value.

Basic Assumptions and Limitations

The block does not model the internal individual MOSFET devices that make up the gate. This limitation has the following implications:

- The block does not accurately model the gate's response to input noise and inputs that are around the logic threshold voltage.
- The block does not accurately model dynamic response.
- The block's linear drop in output voltage as a function of output current is an approximation to the MOSFET output behavior.

To model a logic gate at the device level, use the `netlist2sl` function to import the netlist of the logic gate.

Dialog Box and Parameters

Inputs Tab

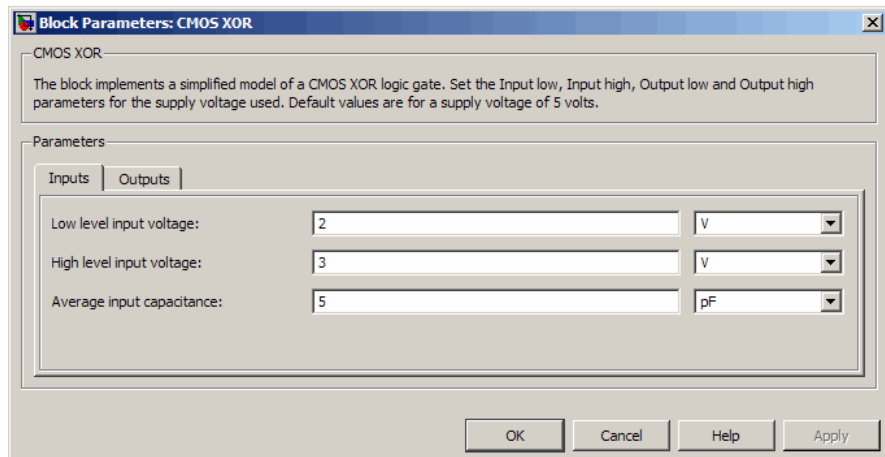

Low level input voltage

Voltage value below which the block interprets the input voltage as logic LOW. The default value is 2 V.

High level input voltage

Voltage value above which the block interprets the input voltage as logic HIGH. The default value is 3 V.

Average input capacitance

Fixed capacitance that approximates the input capacitance for a MOSFET gate. The MOSFET capacitance depends on the applied voltage. When you drive this block with another gate, the **Average input capacitance** produces a rise time similar to that of the MOSFET. You can usually find this capacitance value on a manufacturer datasheet. The default value is 5 pF. Setting this value to zero may result in faster simulation times.

Outputs Tab

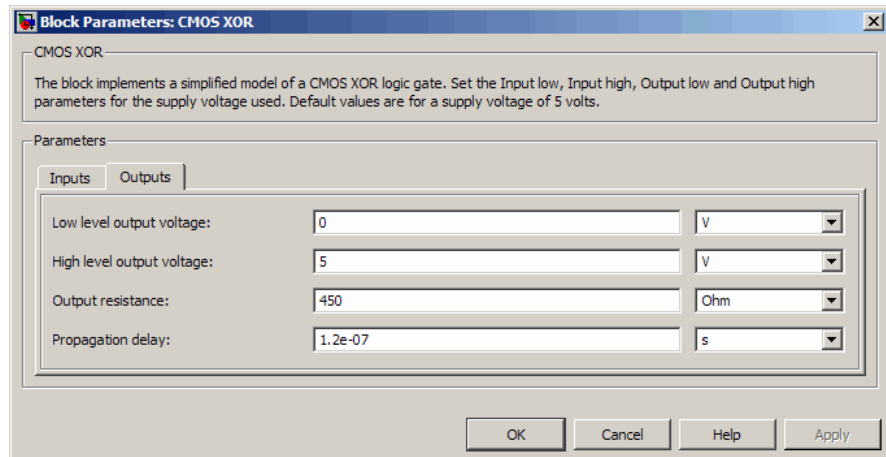

Low level output voltage

Voltage value at the output when the output logic level is LOW. The default value is 0 V.

High level output voltage

Voltage value at the output when the output logic level is HIGH. The default value is 5 V.

Output resistance

Value of the series output resistor that is used to model the drop in output voltage resulting from the output current. The default value is 450 Ω . You can derive this value from a datasheet by

dividing the high-level output voltage by the maximum low-level output current.

Propagation delay

Time it takes for the output to swing from LOW to HIGH or HIGH to LOW after the input logic levels change. The default value is $1.2e-07$ s.

Ports

The block has the following ports:

- A Electrical input port.
- B Electrical input port.
- J Electrical output port.

Comparator

Purpose Model a comparator behaviorally

Library Integrated Circuits

Description

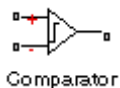

The Comparator block is an abstracted behavioral model of a comparator integrated circuit. It does not model an internal transistor-level implementation. Therefore, the block runs quickly during simulation but retains the correct I/O behavior. The block models differential inputs electrically as having infinite resistance and a finite or zero capacitance.

The block models the gate output as a voltage source driving a series resistor and a capacitor that connects to ground. The output pin connects to the resistor-capacitor connection node. If the difference in the inputs is greater than the input threshold voltage, then the output is equal to the **High level output voltage** (V_{OH}). Otherwise, the output is equal to the **Low level output voltage** (V_{OL}).

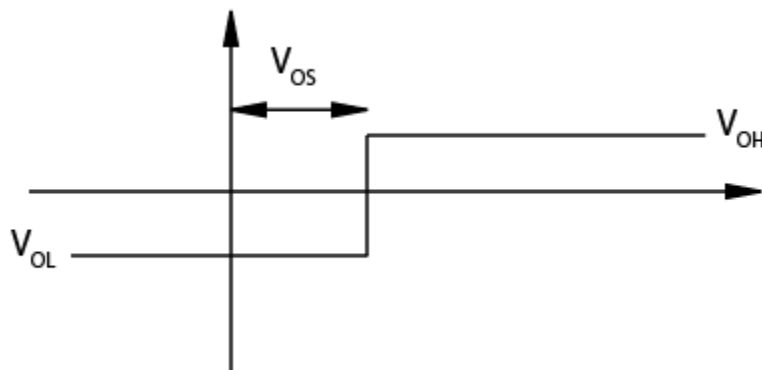

Basic Assumptions and Limitations

Modeling of the output as a controlled voltage source is representative of a totem-pole or push-pull output stage. To model a device with an open-collector:

- 1 Connect the output pin to the base of an NPN Bipolar Transistor or PNP Bipolar Transistor block.
- 2 Set the **Output resistance** parameter to a suitable value.

Dialog Box and Parameters

Inputs Tab

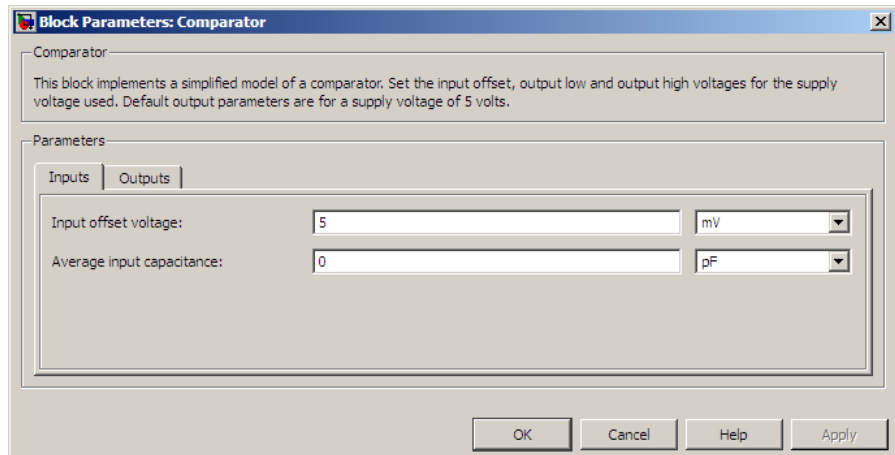

Input offset voltage

The voltage which the difference in the input voltages must be greater than so that the comparator gives a logic output 1. The default value is 5 mV.

Average input capacitance

You can usually find this capacitance value on a manufacturer datasheet. The default value is 0 pF. Setting this value to zero can result in faster simulation times.

Comparator

Outputs Tab

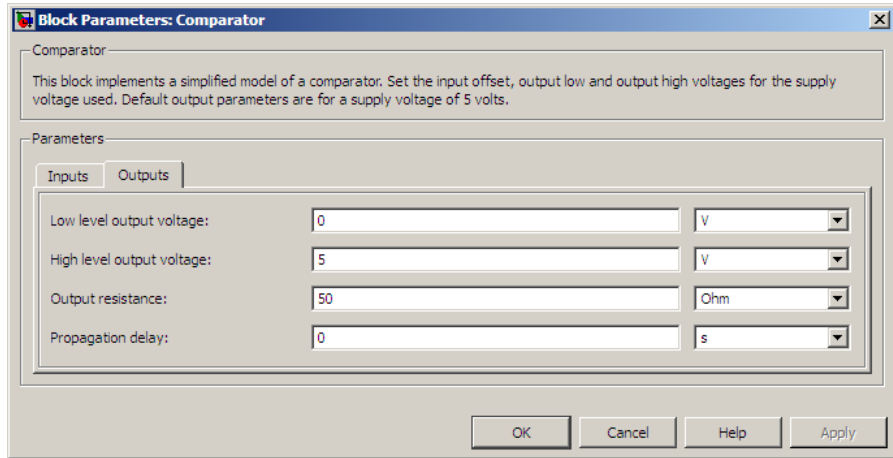

Low level output voltage

The steady-state output voltage, V_{OL} , when the voltage difference across the inputs is less than or equal to the threshold voltage, and the output current is zero. The default value is 0 V.

High level output voltage

The steady-state output voltage, V_{OH} , when the voltage difference across the inputs is greater than the threshold voltage, and the output current is zero. The default value is 5 V.

Output resistance

This parameter is the ratio of output voltage drop to output current. Set this parameter to $(V_{OH} - V_{OH1}) / I_{OH1}$, where V_{OH1} is the reduced output high voltage when the output current is I_{OH1} . The default value is 50 Ω .

Propagation delay

Set this value based on the high-to-low and low-to-high propagation delays. The default value is 0 s.

Ports

This block has the following ports:

- + Positive electrical input port.
- Negative electrical input port.
- OUT Electrical output port.

See Also

CMOS Buffer .

Controlled PWM Voltage

Purpose Model pulse-width modulated voltage source

Library Actuators & Drivers

Description The Controlled PWM Voltage block represents a pulse-width modulated (PWM) voltage source that depends on the reference voltage V_{ref} across its +ref and -ref ports. The duty cycle is

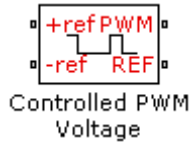

$$100 * \frac{V_{ref} - V_{min}}{V_{max} - V_{min}} \text{ percent}$$

where:

- V_{min} is the minimum reference voltage
- V_{max} is the maximum reference voltage

The value of the **Output voltage amplitude** parameter determines amplitude of the output voltage.

At time zero, the pulse is initialized as high, unless the duty cycle is set to zero.

Basic Assumptions and Limitations

The model is based on the following assumptions:

- The REF output of this block is floating, i.e. it is not tied to the Electrical Reference. One consequence of this is that if you connect the PWM and REF electrical ports directly to the H-Bridge PWM and REF electrical ports, you must attach an Electrical Reference block to the REF connection line.
- Do not use the Controlled PWM block to drive a motor block directly. A PWM motor driver goes open circuit in between pulses. Use the H-Bridge block to drive a motor block.
- When driving a motor via the H-Bridge block, set the **Simulation mode** parameter to **Averaged** to speed up simulations. You must also set the **Simulation mode** parameter of the H-Bridge block to **Averaged** mode. This applies the average of the demanded

PWM voltage to the motor. The Averaged mode assumes that the impedance of the motor inductive term is small at the **PWM frequency**. To verify this assumption, run the simulation using the PWM mode and compare the results to those obtained from using the Averaged mode.

- If you are linearizing your model, set the **Simulation mode** parameter to Averaged and ensure that you have specified the operating point of the block correctly. You can only linearize the block for inputs corresponding to a duty cycle greater than zero and less than 100 percent.

Dialog Box and Parameters

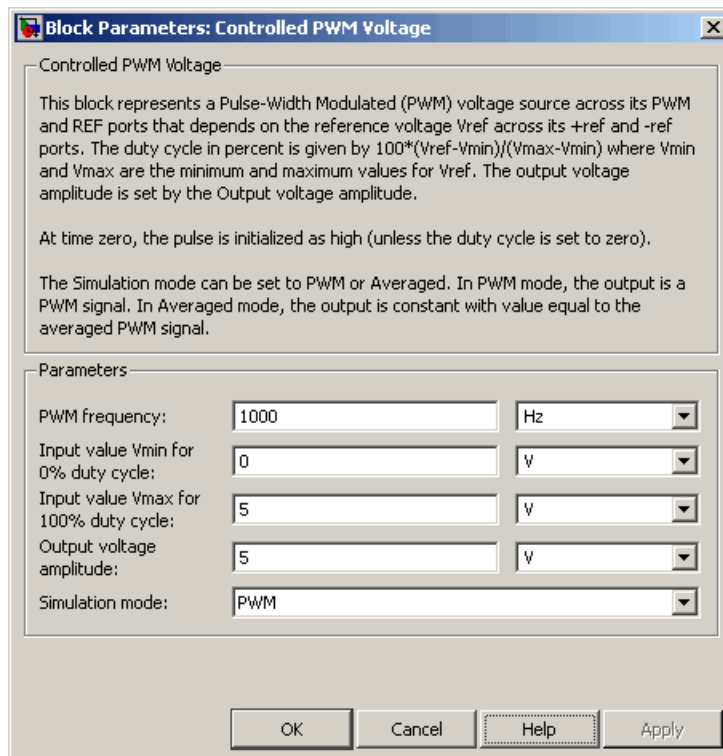

Controlled PWM Voltage

PWM frequency

Frequency of the PWM output signal. The default value is 1000 Hz.

Input value Vmin for 0% duty cycle

Value of the input voltage at which the PWM signal has a 0% duty cycle. The default value is 0 V.

Input value Vmax for 100% duty cycle

Value of the input voltage at which the PWM signal has a 100% duty cycle. The default value is 5 V.

Output voltage amplitude

Amplitude of the PWM signal when the output is high. The default value is 5 V.

Simulation mode

The type of output voltage can be PWM or Averaged. The default mode, PWM, produces a pulse-width modulated signal. In Averaged mode, the output is a constant whose value is equal to the average value of the PWM signal.

Ports

The block has the following ports:

+ref

Positive electrical reference voltage.

-ref

Negative electrical reference voltage.

PWM

Pulse-width modulated signal.

REF

Floating zero volt reference.

Examples

See the Linear Electrical Actuator (System-Level Model) and Linear Electrical Actuator (Implementation Model) demos.

See Also

Stepper Motor Driver

Purpose Model stable resonator

Library Passive Devices

Description



Crystal

The Crystal block represents the electrical characteristics of a crystal. The following figure shows the equivalent circuit model of the Crystal block.

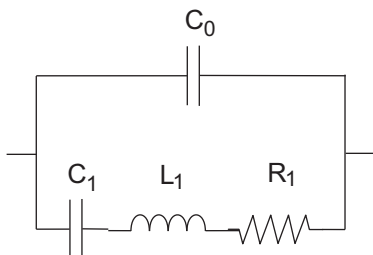

You specify the equivalent circuit parameters for this model when you set the **Parameterization** parameter to **Equivalent circuit parameters**.

- The capacitor C_0 corresponds to the capacitance you specify in the **Shunt capacitance, C_0** parameter.
- The capacitor C_1 corresponds to the capacitance you specify in the **Motional capacitance, C_1** parameter.
- The inductor L_1 corresponds to the inductance you specify in the **Motional inductance, L_1** parameter.
- The resistor R_1 corresponds to the resistance you specify in the **Equivalent series resistance, R_1** parameter.

Most datasheets specify crystal frequency rather than inductance, so the block optionally accepts frequency data.

- When you set the **Parameterization** parameter to **Series resonance data**, the block uses the following relationship to calculate $L1$ from the series resonant frequency:

$$f_s = \frac{1}{2\pi\sqrt{L_1C_1}}$$

Where f_s is the **Series resonance, fs** parameter value.

- When you set the **Parameterization** parameter to **Parallel resonance data**, the block uses the following relationship to calculate $L1$ from the parallel resonant frequency:

$$f_a = \frac{1}{2\pi\sqrt{L_1C_1(C_0 + C_L)/(C_1 + C_0 + C_L)}}$$

Where:

- f_a is the **Parallel resonance, fa** parameter value.
- C_L is the **Load capacitance, CL** parameter value.

Some datasheets specify quality factor rather than equivalent series resistance, so the block optionally accepts quality factor data. When you set the **R1 parameterization** parameter to **Quality factor Q**, the block uses the following relationship to calculate $R1$ from the quality factor:

$$Q = \frac{2\pi fL_1}{R_1}$$

Where Q is the **Quality factor, Q** parameter value.

Note The **R1 parameterization** parameter is only visible when you select **Series resonance data** or **Parallel resonance data** for the **Parameterization** parameter.

Basic Assumptions and Limitations

Dialog Box and Parameters

The Crystal block models only the fundamental crystal vibration mode.

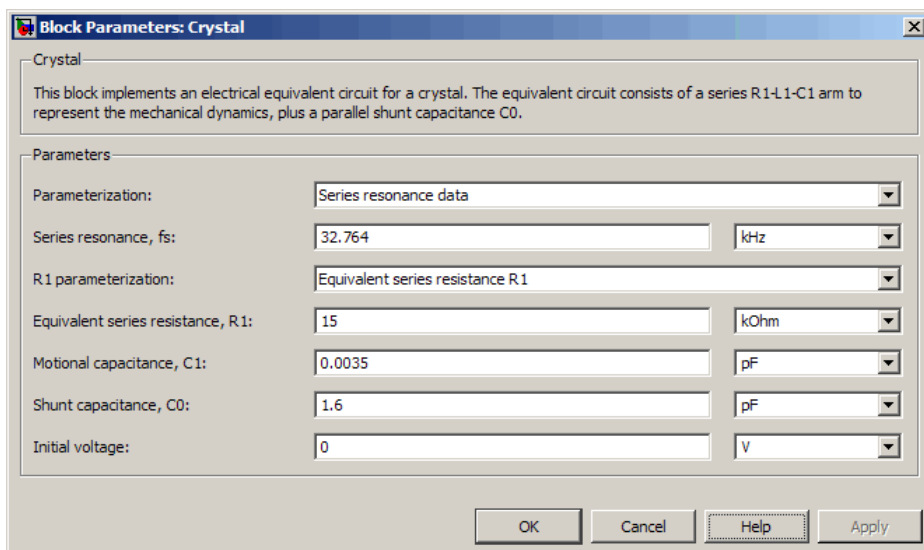

Parameterization

Select one of the following methods for block parameterization:

- **Series resonance data** — Provide series resonant frequency and capacitance data for the crystal. This method is the default.
- **Parallel resonance data** — Provide parallel resonant frequency and capacitance data for the crystal.
- **Equivalent circuit parameters** — Provide electrical parameters for an equivalent circuit model of the crystal.

Series resonance, fs

Crystal series resonant frequency. This parameter is only visible when you select **Series resonance data** for the **Parameterization** parameter. The default value is 32.764 kHz.

Parallel resonance, fa

Crystal parallel resonant frequency that corresponds to operating with a parallel load capacitance specified by the **Load capacitance, CL** parameter. This parameter is only visible when you select **Parallel resonance data** for the **Parameterization** parameter. The default value is 32.768 kHz.

Motional inductance, L1

Inductance that represents the mechanical mass of the crystal. This parameter is only visible when you select **Equivalent circuit parameters** for the **Parameterization** parameter. The default value is 6.742e+03 H.

R1 parameterization

Select one of the following methods for series resistance parameterization:

- **Equivalent series resistance R1** — Provide the resistance value directly. This is the default method.
- **Quality factor Q** — Provide the quality factor that the block uses to calculate the resistance value.

This parameter is only visible when you select **Series resonance data** or **Parallel resonance data** for the **Parameterization** parameter.

Quality factor, Q

Crystal quality factor. This parameter is only visible when you make one of the following selections:

- **Series resonance data** for the **Parameterization** parameter and **Quality factor Q** for the **R1 parameterization** parameter

- Parallel resonance data for the **Parameterization** parameter and Quality factor **Q** for the **R1 parameterization** parameter

The default value is $9e+04$.

Equivalent series resistance, R1

Motional damping term. This parameter is only visible when you make one of the following selections:

- Series resonance data for the **Parameterization** parameter and Equivalent series resistance **R1** for the **R1 parameterization** parameter
- Parallel resonance data for the **Parameterization** parameter and Equivalent series resistance **R1** for the **R1 parameterization** parameter
- Equivalent circuit parameters for the **Parameterization** parameter

The default value is 15 k Ω .

Motional capacitance, C1

Capacitance that represents crystal mechanical stiffness under load. The default value is 0.0035 pF.

Load capacitance, CL

Load capacitance that corresponds to the **Parallel resonance, fa** parameter value. This parameter is only visible when you select Parallel resonance data for the **Parameterization** parameter. The default value is 12.5 pF.

Shunt capacitance, C0

Electrical capacitance between the two crystal electrical connections. The parameter value must be greater than zero. The default value is 1.6 pF.

Initial voltage

The output voltage at the start of the simulation when the output current is zero. The default value is 0 V.

Ports

The block has the following ports:

Crystal

+ Positive electrical port.

- Negative electrical port.

Purpose Model current-controlled switch with hysteresis

Library Passive Devices

Description

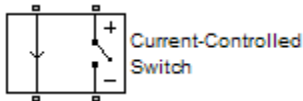

The Current-Controlled Switch block represents the electrical characteristics of a switch whose state is controlled by the current through the input ports (the *controlling current*):

- When the controlling current is greater than the sum of the **Threshold current, I_T** and **Hysteresis current, I_H** parameter values, the switch is closed and has a resistance equal to the **On resistance, R_{ON}** parameter value.
- When the controlling current is less than the **Threshold current, I_T** parameter value minus the **Hysteresis current, I_H** parameter value, the switch is open and has a resistance equal to the **Off resistance, R_{OFF}** parameter value.
- When the controlling current is greater than or less than the **Threshold current, I_T** parameter value by an amount less than or equal to the **Hysteresis current, I_H** parameter value, the current is in the *crossover region* and the state of the switch remains unchanged.

Basic Assumptions and Limitations

The block output resistance model is discontinuous during switching. The discontinuity might cause numerical issues. Try the following actions to resolve the issues:

- Set the **On resistance, R_{ON}** and **Off resistance, R_{OFF}** parameter values to keep the ratio R_{ON}/R_{OFF} as small as possible, and less than $1e+12$.
- Increase the **Hysteresis current, I_H** parameter value to reduce switch chatter.

Current-Controlled Switch

- Decrease the **Max step size** parameter value (in the Configuration Parameters block dialog box).

Note This increases the simulation time.

Dialog Box and Parameters

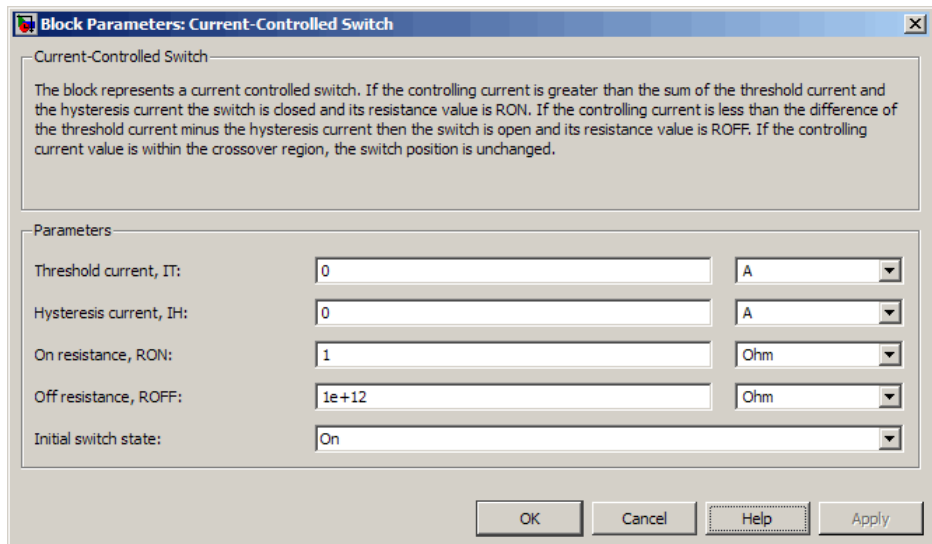

Threshold current, IT

The current above which the block interprets the controlling current as HIGH. The default value is 0 A.

Note The controlling current must differ from the threshold current by at least the **Hysteresis current, IH** parameter value to change the state of the switch.

Hysteresis current, **IH**

The amount by which the controlling current must exceed or fall below the **Threshold current, IT** parameter value to change the state of the switch. The default value is 0 A.

On resistance, **RON**

The resistance of the switch when it is closed. The default value is 1 Ω .

Off resistance, **ROFF**

The resistance of the switch when it is open. The default value is 1e+12 Ω .

Initial switch state

Select one of the following options for the state of the switch at the start of the simulation:

- **On** — The switch is initially closed and its resistance value is equal to the **On resistance, RON** parameter value. This is the default option.
- **Off** — The switch is initially open and its resistance value is equal to the **Off resistance, ROFF** parameter value.

Ports

The block has the following ports:

+

Positive electrical input and output ports.

-

Negative electrical input and output ports.

DC Current Source

Purpose Model constant current source

Library SPICE-Compatible Sources

Description

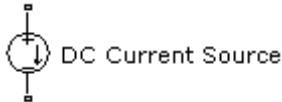

The DC Current Source block represents a constant current source whose output current value is independent of the voltage across its terminals.

The block uses a small conductance internally to prevent numerical simulation issues. The conductance connects the + and - ports of the device and has a conductance *GMIN*:

- By default, *GMIN* matches the **Minimum conductance GMIN** parameter of the SPICE Environment Parameters block, whose default value is $1e-12$.
- To change *GMIN*, add a SPICE Environment Parameters block to your model and set the **Minimum conductance GMIN** parameter to the desired value.

Dialog Box and Parameters

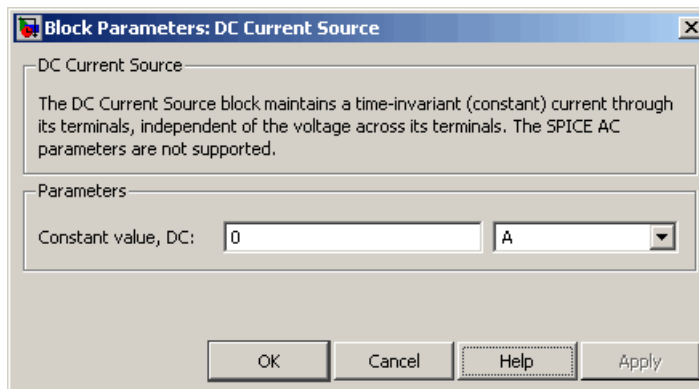

Constant value, DC

The value of the DC output current. The default value is 0 A.

Ports

The block has the following ports:

+

Positive electrical voltage.

-

Negative electrical voltage.

See Also

DC Voltage Source

DC Motor

Purpose Model electrical and torque characteristics of DC motor

Library Actuators & Drivers

Description

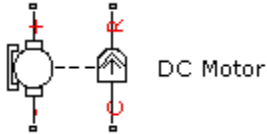

The DC Motor block represents the electrical and torque characteristics of a DC motor using the following equivalent circuit model:

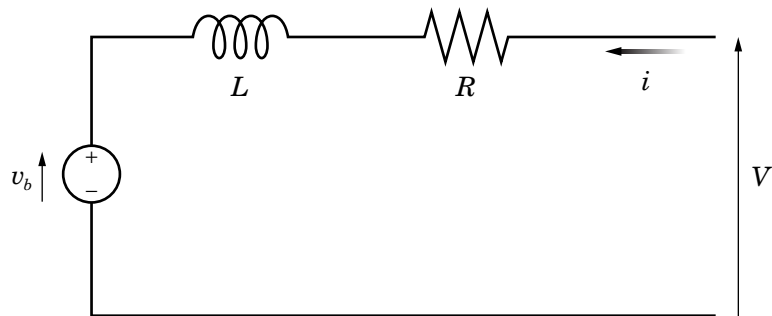

You specify the equivalent circuit parameters for this model when you set the **Model parameterization** parameter to **By equivalent circuit parameters**. The resistor R corresponds to the resistance you specify in the **Armature resistance** parameter. The inductor L corresponds to the inductance you specify in the **Armature inductance** parameter. The permanent magnets in the motor induce the following back emf v_b in the armature:

$$v_b = k_v \omega$$

where k_v is the **Back-emf constant** and ω is the angular velocity. The motor produces the following torque, which is proportional to the motor current i :

$$T = k_t i$$

where k_t is the **Torque constant**. The DC Motor block assumes that there are no electromagnetic losses. This means that mechanical power is equal to the electrical power dissipated by the back emf in the armature. Equating these two terms gives:

$$T\omega = v_b i$$

$$k_t i \omega = k_v \omega i$$

$$k_v = k_t$$

As a result, you specify either k_v or k_t in the block dialog box.

The torque-speed characteristic for the DC Motor block is related to the parameters in the preceding figure. When you set the **Model parameterization** parameter to **By stall torque & no-load speed** or **By rated power, rated speed & no-load speed**, the block solves for the equivalent circuit parameters as follows:

- 1 For the steady-state torque-speed relationship, L has no effect.
- 2 Sum the voltages around the loop and rearrange for i :

$$i = \frac{V - v_b}{R} = \frac{V - k_v \omega}{R}$$

- 3 Substitute this value of i into the equation for torque:

$$T = \frac{k_t}{R} (V - k_v \omega)$$

When you set the **Model parameterization** parameter to **By stall torque & no-load speed**, the block uses the preceding equation to determine values for R and k_t (and equivalently k_v).

DC Motor

When you set the **Model parameterization** parameter to **By rated power, rated speed & no-load speed**, the block uses the rated speed and power to calculate the rated torque. The block uses the rated torque and no-load speed values in the preceding equation to determine values for R and k_t .

The block models motor inertia J and damping B for all values of the **Model parameterization** parameter. The output torque is:

$$T_{load} = \frac{k_t}{R}(V - k_v \omega) - J\dot{\omega} - B\omega$$

When a positive current flows from the electrical + to - ports, a positive torque acts from the mechanical C to R ports.

Dialog Box and Parameters

Electrical Torque Tab

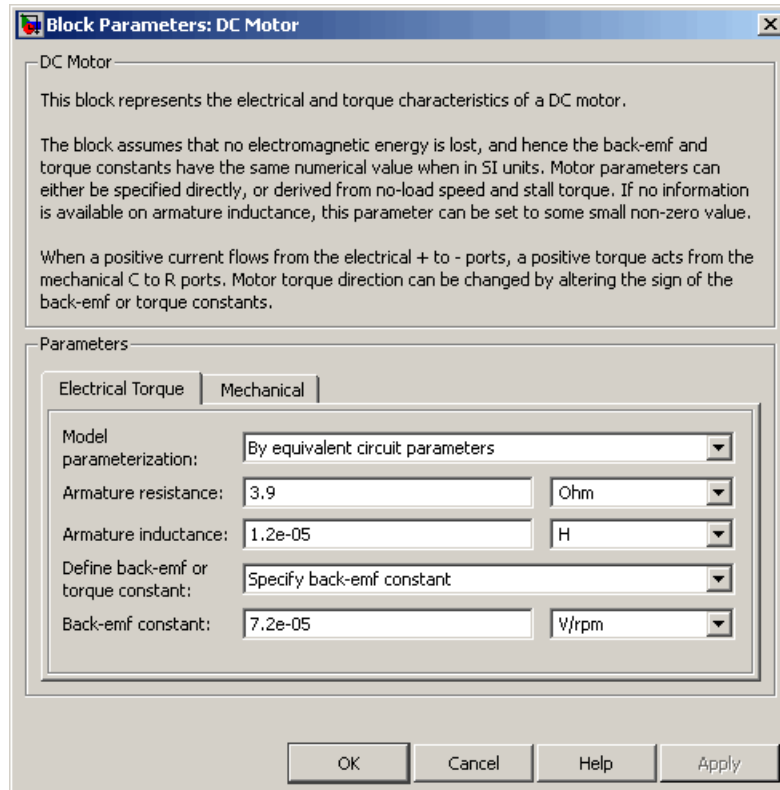

Model parameterization

Select one of the following methods for block parameterization:

- **By equivalent circuit parameters** — Provide electrical parameters for an equivalent circuit model of the motor. This is the default method.
- **By stall torque & no-load speed** — Provide torque and speed parameters that the block converts to an equivalent circuit model of the motor.

- By rated power, rated speed & no-load speed — Provide power and speed parameters that the block converts to an equivalent circuit model of the motor.

Armature resistance

Resistance of the conducting portion of the motor. This parameter is only visible when you select **By equivalent circuit parameters** for the **Model parameterization** parameter. The default value is 3.9 Ω .

Armature inductance

Inductance of the conducting portion of the motor. If you do not have information about this inductance, set the value of this parameter to a small, nonzero number. The default value is 1.2e-05 H.

Define back-emf or torque constant

Indicate whether you will specify the motor's back-emf constant or torque constant. When you specify them in SI units, these constants have the same value, so you only specify one or the other in the block dialog box. This parameter is only visible when you select **By equivalent circuit parameters** for the **Model parameterization** parameter. The default value is **Specify back-emf constant**.

Back-emf constant

The ratio of the voltage generated by the motor to the speed at which the motor is spinning. The default value is 7.2e-05 V/rpm. This parameter is only visible when you select **Specify back-emf constant** for the **Define back-emf or torque constant** parameter.

Torque constant

The ratio of the torque generated by the motor to the current delivered to it. This parameter is only visible when you select **Specify torque constant** for the **Define back-emf or torque constant** parameter. The default value is 6.876e-04 N*m/A.

Stall torque

The amount of torque generated by the motor when the speed is approximately zero. This parameter is only visible when you select **By stall torque & no-load speed** for the **Model parameterization** parameter. The default value is $2.4e-04$ N*m.

No-load speed

Speed of the motor when not driving a load. This parameter is only visible when you select **By stall torque & no-load speed** or **By rated power, rated speed & no-load speed** for the **Model parameterization** parameter. The default value is $1.91e+04$ rpm.

Rated speed (at rated load)

Motor speed at the rated mechanical power level. This parameter is only visible when you select **By rated power, rated speed & no-load speed** for the **Model parameterization** parameter. The default value is $1.5e+04$ rpm.

Rated load (mechanical power)

The mechanical power the motor is designed to deliver at the rated speed. This parameter is only visible when you select **By rated power, rated speed & no-load speed** for the **Model parameterization** parameter. The default value is 0.08 W.

Rated DC supply voltage

The voltage at which the motor is rated to operate. This parameter is only visible when you select **By stall torque & no-load speed** or **By rated power, rated speed & no-load speed** for the **Model parameterization** parameter. The default value is 1.5 V.

Mechanical Tab

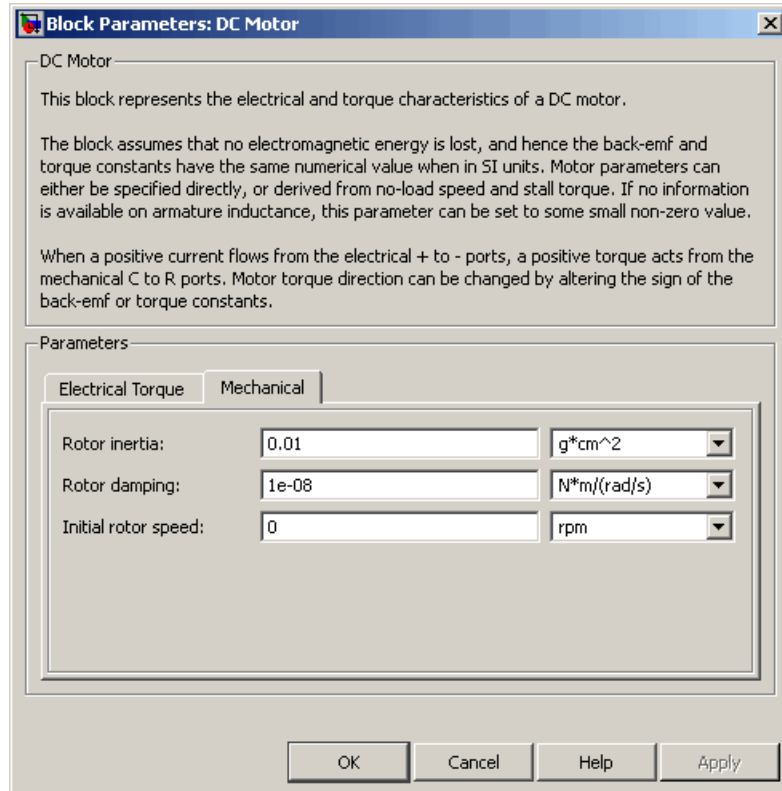

Rotor inertia

Resistance of the rotor to change in motor motion. The default value is 0.01 g*cm². The value can be zero.

Rotor damping

Energy dissipated by the rotor. The default value is 1e-08 N*m/(rad/s). The value can be zero.

Initial rotor speed

Speed of the rotor at the start of the simulation. The default value is 0 rpm.

Ports

The block has the following ports:

- + Positive electrical input.
- Negative electrical input.
- C Mechanical rotational conserving port.
- R Mechanical rotational conserving port.

Examples

See the following demos:

- Linear Electrical Actuator (Motor Model)
- Linear Electrical Actuator (System-Level Model)
- Linear Electrical Actuator (Implementation Model)

References

[1] Bolton, W. Mechatronics: Electronic Control Systems in Mechanical and Electrical Engineering, 3rd edition Pearson Education, 2004.

See Also

Induction Motor, Servomotor, Shunt Motor, and Universal Motor.

DC Voltage Source

Purpose Model constant voltage source

Library SPICE-Compatible Sources

Description

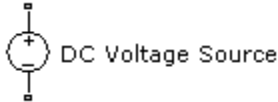

The DC Voltage Source block represents a constant voltage source whose output voltage value is independent of the current through the source.

Dialog Box and Parameters

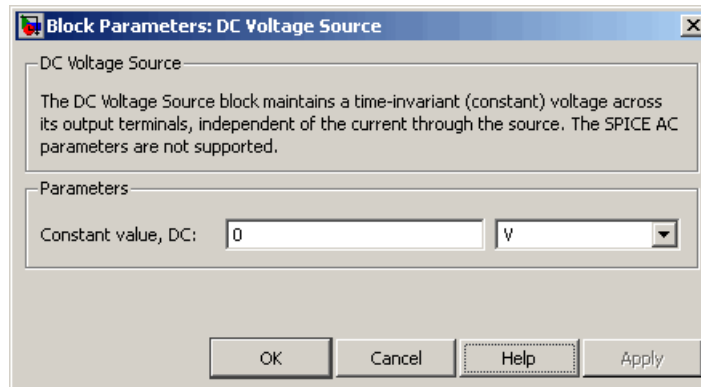

Constant value, DC

The value of the DC output voltage. The default value is 0 V.

Ports

The block has the following ports:

- + Positive electrical voltage.
- Negative electrical voltage.

See Also DC Current Source

Diode

Purpose Model piecewise linear, piecewise linear zener, or exponential diode

Library Semiconductor Devices

Description The Diode block represents one of the following types of diodes:

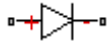

Diode

- “Piecewise Linear” on page 2-62
- “Piecewise Linear Zener” on page 2-62
- “Exponential” on page 2-63

Piecewise Linear

The piecewise linear diode model is the same model found in the Simscape Diode block, with the addition of a fixed junction capacitance. If the diode forward voltage exceeds the value specified in the **Forward voltage** parameter, the diode behaves as a linear resistor with the resistance specified in the **On resistance** parameter. Otherwise, the diode behaves as a linear resistor with the small conductance specified in the **Off conductance** parameter. Zero voltage across the diode results in zero current flowing.

Piecewise Linear Zener

The piecewise linear zener diode model behaves like the piecewise linear diode model for bias voltages above $-V_z$, where V_z is the **Reverse breakdown voltage V_z** parameter value. For voltages less than $-V_z$, the diode behaves as a linear resistor with the low Zener resistance specified in the **Zener resistance R_z** parameter. This diode model also includes a fixed junction capacitance.

Note The **Reverse breakdown voltage V_z** parameter is defined as a positive number. The p-n voltage at breakdown is $-V_z$, which is negative.

Exponential

The exponential diode model provides the following relationship between the diode current I and the diode voltage V :

$$I = IS \times \left(e^{\frac{qV}{NkT}} - 1 \right) \quad V > -V_z$$

$$I = -IS \times \left(e^{\frac{-q(V+V_z)}{kT}} - e^{\frac{qV}{NkT}} \right) \quad V \leq -V_z$$

where:

- q is the elementary charge on an electron (1.602176e-19 Coulombs).
- k is the Boltzmann constant (1.3806503e-23 J/K).
- V_z is the **Reverse breakdown voltage BV** parameter value.
- N is the emission coefficient.
- IS is the saturation current.
- T is the temperature at which the diode parameters are specified, as defined by the **Measurement temperature** parameter value.

When $\frac{qV}{NkT} > 80$, the block replaces $e^{\frac{qV}{NkT}}$ with $\left(\frac{qV}{NkT} - 79 \right) e^{80}$, which matches the gradient of the diode current at $qV/(NkT) = 80$ and

extrapolates linearly. When $\frac{qV}{NkT} < -79$, the block replaces $e^{\frac{qV}{NkT}}$ with

$\left(\frac{qV}{NkT} + 80 \right) e^{-79}$, which also matches the gradient and extrapolates linearly. Typical electrical circuits do not reach these extreme values. The block provides this linear extrapolation to help convergence when solving for the constraints during simulation.

When you select Use parameters IS and N for the **Parameterization** parameter, you specify the diode in terms of the **Saturation current** IS and **Emission coefficient** N parameters. When you select Use I-V curve data points for the **Parameterization** parameter, you specify two voltage and current measurement points on the diode I-V curve and the block derives the IS and N values. When you specify current and voltage measurements, the block calculates IS and N as follows:

- $N = ((V_1 - V_2) / V_t) / (\log(I_1) - \log(I_2))$
- $IS = (I_1 / (\exp(V_1 / (NV_t)) - 1) + I_2 / (\exp(V_2 / (NV_t)) - 1)) / 2$

where:

- $V_t = kT / q$.
- V_1 and V_2 are the values in the **Voltages [V1 V2]** vector.
- I_1 and I_2 are the values in the **Currents [I1 I2]** vector.

The exponential diode model provides the option to include a junction capacitance:

- When you select Include fixed or zero junction capacitance for the **Junction capacitance** parameter, the capacitance is fixed.
- When you select Use parameters CJO , VJ , M & FC for the **Junction capacitance** parameter, the block uses the coefficients CJO , VJ , M , and FC to calculate a junction capacitance that depends on the junction voltage.
- When you select Use C-V curve data points for the **Junction capacitance** parameter, the block uses three capacitance values on the C-V capacitance curve to estimate CJO , VJ , and M and uses these values with the specified value of FC to calculate a junction capacitance that depends on the junction voltage. The block calculates CJO , VJ , and M as follows:

- $CJ0 = C_1((V_{R2} - V_{R1}) / (V_{R2} - V_{R1}(C_2 / C_1)^{-1/M}))^M$
- $VJ = -(-V_{R2}(C_1 / C_2)^{-1/M} + V_{R1}) / (1 - (C_1 / C_2)^{-1/M})$
- $M = \log(C_3 / C_2) / \log(V_{R2} / V_{R3})$

where:

- V_{R1} , V_{R2} , and V_{R3} are the values in the **Reverse bias voltages [VR1 VR2 VR3]** vector.
- C_1 , C_2 , and C_3 are the values in the **Corresponding capacitances [C1 C2 C3]** vector.

It is not possible to estimate FC reliably from tabulated data, so you must specify its value using the **Capacitance coefficient FC** parameter. In the absence of suitable data for this parameter, use a typical value of 0.5.

The reverse bias voltages (defined as positive values) should satisfy $V_{R3} > V_{R2} > V_{R1}$. This means that the capacitances should satisfy $C_1 > C_2 > C_3$ as reverse bias widens the depletion region and hence reduces capacitance. Violating these inequalities results in an error. Voltages V_{R2} and V_{R3} should be well away from the Junction potential VJ . Voltage V_{R1} should be less than the Junction potential VJ , with a typical value for V_{R1} being 0.1 V.

The voltage-dependent junction is defined in terms of the capacitor charge storage Q_j as:

- For $V < FC \times VJ$:

$$Q_j = CJ0 \times (VJ / (M - 1)) \times ((1 - V / VJ)^{1-M} - 1)$$

- For $V \geq FC \times VJ$:

$$Q_j = CJ0 \times F_1 + (CJ0 / F_2) \times (F_3 \times (V - FC \times VJ) + 0.5 * (M / VJ) * (V^2 - (FC \times VJ)^2))$$

where:

- $F_1 = (VJ / (1 - M)) \times (1 - (1 - FC)^{1-M})$
- $F_2 = (1 - FC)^{1+M}$
- $F_3 = 1 - FC \times (1 + M)$

These equations are the same as used in [2], except that the temperature dependence of VJ and FC is not modeled. This model does not include the diffusion capacitance term that affects performance for high frequency switching applications.

Basic Assumptions and Limitations

The Exponential diode model has the following limitations:

- When you select Use I-V curve data points for the **Parameterization** parameter, choose a pair of voltages near the diode turn-on voltage. Typically, this is in the range from 0.05 to 1 Volt. Using values outside of this region may lead to numerical issues and poor estimates for IS and N .
- This block does not model temperature-dependent effects. SimElectronics® simulates the block at the temperature at which the component behavior was measured, as specified by the **Measurement temperature** parameter value.
- You may need to use nonzero ohmic resistance and junction capacitance values to prevent numerical simulation issues, but the simulation may run faster with these values set to zero.

Dialog Box and Parameters

Main Tab

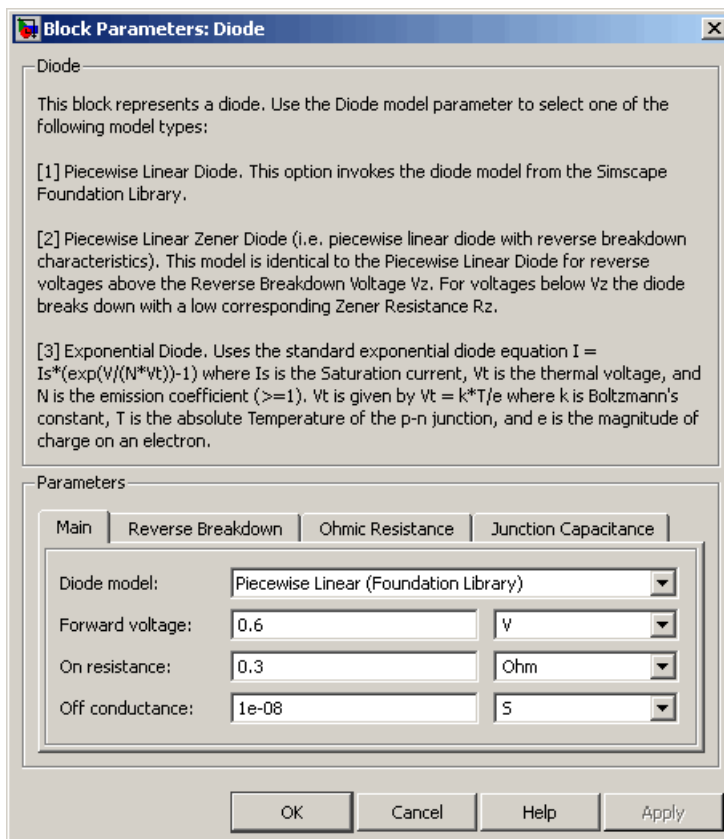

Diode model

Select one of the following diode models:

- **Piecewise Linear (Foundation Library)** — Use a piecewise linear model for the diode, as described in “Piecewise Linear” on page 2-62. This is the default method.

- **Piecewise Linear Zener** — Use a piecewise linear model with reverse breakdown characteristics for the diode, as described in “Piecewise Linear Zener” on page 2-62.
- **Exponential** — Use a standard exponential model for the diode, as described in “Exponential” on page 2-63.

Forward voltage

Minimum voltage that needs to be applied for the diode to become forward-biased. This parameter is only visible when you select **Piecewise Linear (Foundation Library)** or **Piecewise Linear Zener** for the **Diode model** parameter. The default value is 0.6 V.

On resistance

The resistance of the diode when it is forward biased. This parameter is only visible when you select **Piecewise Linear (Foundation Library)** or **Piecewise Linear Zener** for the **Diode model** parameter. The default value is 0.3 Ω .

Off conductance

The conductance of the diode when it is reverse biased. This parameter is only visible when you select **Piecewise Linear (Foundation Library)** or **Piecewise Linear Zener** for the **Diode model** parameter. The default value is 1e-08 1/ Ω .

Parameterization

Select one of the following methods for model parameterization:

- **Use I-V curve data points** — Specify measured data at two points on the diode I-V curve. This is the default method.
- **Use parameters IS and N** — Specify saturation current and emission coefficient.

Currents [I1 I2]

A vector of the current values at the two points on the diode I-V curve that the block uses to calculate *IS* and *N*. This parameter is only visible when you select **Exponential** for the **Diode model** parameter and **Use I-V curve data points** for the

Parameterization parameter. The default value is [0.07 1.5] A.

Voltages [V1 V2]

A vector of the voltage values at the two points on the diode I-V curve that the block uses to calculate IS and N . This parameter is only visible when you select **Exponential** for the **Diode model** parameter and **Use I-V curve data points** for the **Parameterization** parameter. The default value is [0.7 0.8] V.

Saturation current IS

The magnitude of the current that the ideal diode equation approaches asymptotically for very large reverse bias levels. This parameter is only visible when you select **Exponential** for the **Diode model** parameter and **Use parameters IS and N** for the **Parameterization** parameter. The default value is $1e-14$ A.

Measurement temperature

The temperature at which IS or the I-V curve was measured. This parameter is only visible when you select **Exponential** for the **Diode model** parameter. The default value is 25 °C.

Emission coefficient N

The diode emission coefficient or ideality factor. This parameter is only visible when you select **Exponential** for the **Diode model** parameter and **Use parameters IS and N** for the **Parameterization** parameter. The default value is 1.

Reverse Breakdown Tab

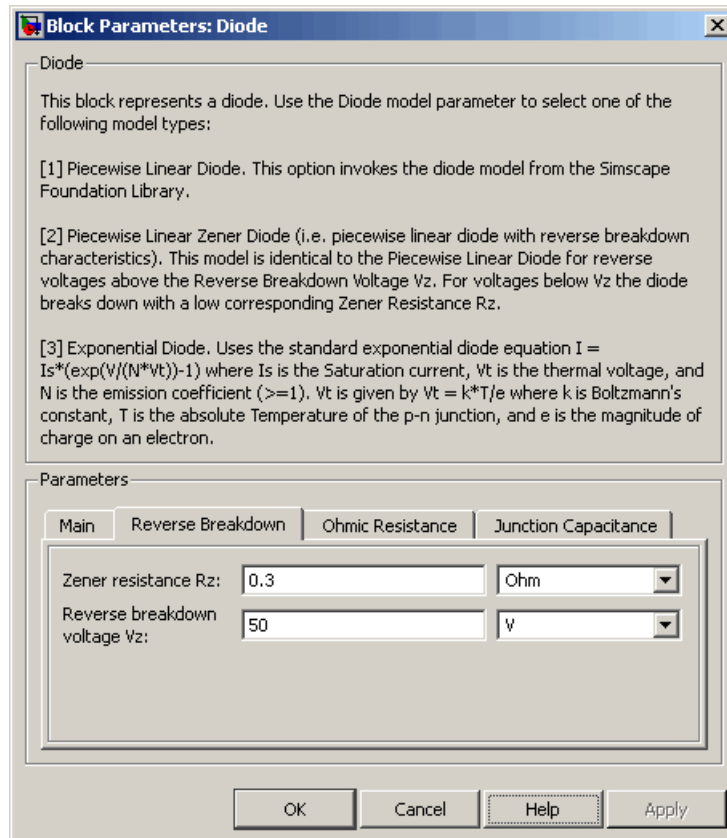

Zener resistance R_z

The resistance of the diode when the voltage is less than the **Reverse breakdown voltage V_z** value. This parameter is only visible when you select **Piecewise Linear Zener** for the **Diode model** parameter. The default value is 0.3 Ω .

Reverse breakdown voltage V_z

The reverse voltage below which the diode resistance changes to the **Zener resistance R_z** value. This parameter is only visible when you select Piecewise Linear Zener for the **Diode model** parameter. The default value is 50 V.

Reverse breakdown voltage BV

The reverse voltage below which to model the rapid increase in conductance that occurs at diode breakdown. This parameter is only visible when you select Exponential for the **Diode model** parameter. The default value is Inf V, which effectively omits reverse breakdown from the model.

Ohmic Resistance Tab

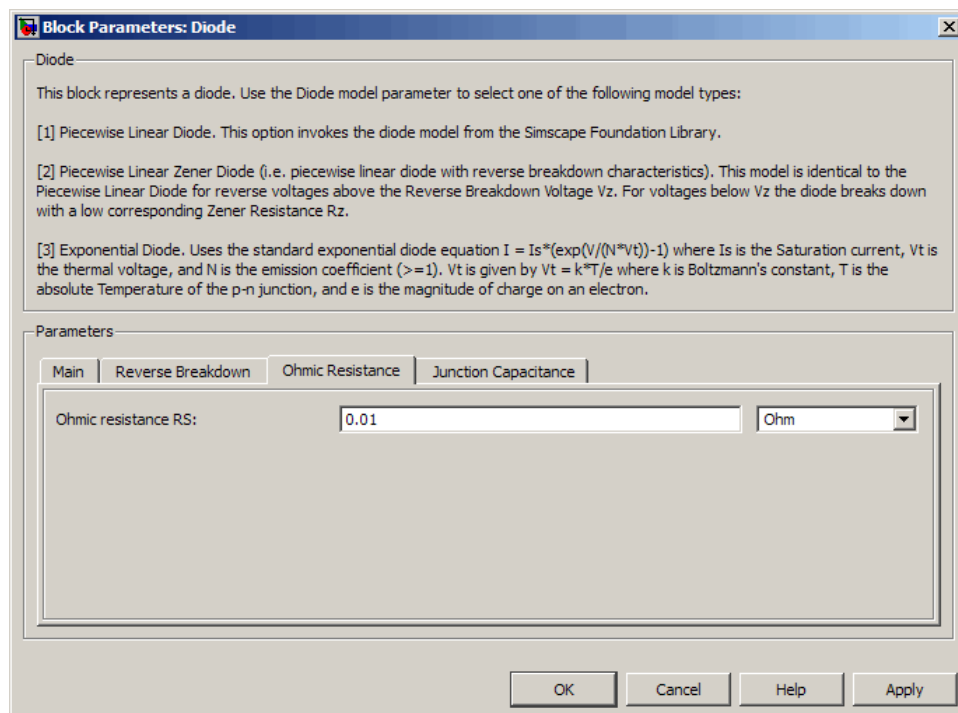

Ohmic resistance RS

The series diode connection resistance. This parameter is only visible when you select Exponential for the **Diode model** parameter. The default value is 0.01 Ω .

Junction Capacitance Tab

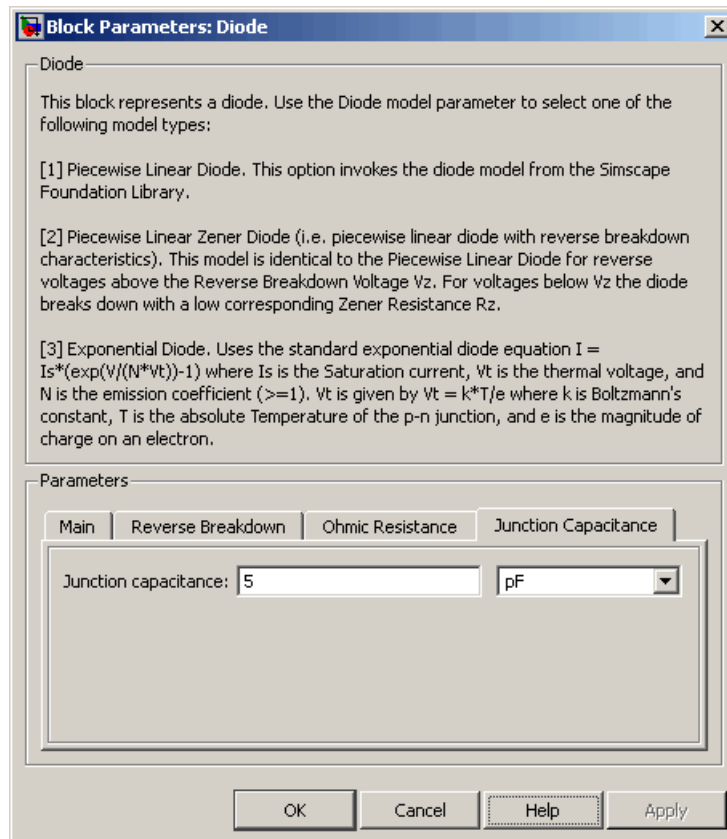

Junction capacitance

- When you select Piecewise Linear (Foundation Library) or Piecewise Linear Zener for the **Diode model** parameter, the **Junction capacitance** parameter is the fixed junction capacitance value. The default value is 5 pF.
- When you select Exponential for the **Diode model** parameter, the **Junction capacitance** parameter lets you select one of the following options for modeling the junction capacitance:
 - Include fixed or zero junction capacitance — Model the junction capacitance as a fixed value.
 - Use C-V curve data points — Specify measured data at three points on the diode C-V curve.
 - Use parameters CJO, VJ, M & FC — Specify zero-bias junction capacitance, junction potential, grading coefficient, and forward-bias depletion capacitance coefficient.

Zero-bias junction capacitance CJO

The value of the capacitance placed in parallel with the exponential diode term. This parameter is only visible when you select Exponential for the **Diode model** parameter and Include fixed or zero junction capacitance or Use parameters CJO, VJ, M & FC for the **Junction capacitance** parameter. The default value is 5 pF.

Reverse bias voltages [VR1 VR2 VR3]

A vector of the reverse bias voltage values at the three points on the diode C-V curve that the block uses to calculate CJO , VJ , and M . This parameter is only visible when you select Use C-V curve data points for the **Junction capacitance** parameter. The default value is [0.1 10 100] V.

Corresponding capacitances [C1 C2 C3]

A vector of the capacitance values at the three points on the diode C-V curve that the block uses to calculate CJO , VJ , and M . This parameter is only visible when you select Use C-V curve data

Diode

points for the **Junction capacitance** parameter. The default value is [3.5 1 0.4] pF.

Junction potential VJ

The junction potential. This parameter is only visible when you select Exponential for the **Diode model** parameter and Use parameters CJO, VJ, M & FC for the **Junction capacitance** parameter. The default value is 1 V.

Grading coefficient M

The grading coefficient. This parameter is only visible when you select Exponential for the **Diode model** parameter and Use parameters CJO, VJ, M & FC for the **Junction capacitance** parameter. The default value is 0.5.

Capacitance coefficient FC

Fitting coefficient that quantifies the decrease of the depletion capacitance with applied voltage. This parameter is only visible when you select Exponential for the **Diode model** parameter and Use C-V curve data points or Use parameters CJO, VJ, M & FC for the **Junction capacitance** parameter. The default value is 0.5.

Ports

The block has the following ports:

+

Electrical conserving port associated with the diode positive terminal.

-

Electrical conserving port associated with the diode negative terminal.

References

[1] MH. Ahmed and P.J. Spreadbury. *Analogue and digital electronics for engineers*. 2nd Edition, Cambridge University Press, 1984.

[2] G. Massobrio and P. Antognetti. *Semiconductor Device Modeling with SPICE*. 2nd Edition, McGraw-Hill, 1993.

See Also Simscape Diode, Diode (SPICE)

Diode (SPICE)

Purpose Model SPICE-compatible diode

Library SPICE-Compatible Semiconductors

Description The Diode block represents a SPICE-compatible diode.

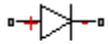

Diode

The Diode block model includes the following components:

- “Current-Voltage Model” on page 2-76
- “Junction Charge Model” on page 2-78
- “Temperature Dependence” on page 2-79

Current-Voltage Model

The block provides the following relationship between the diode current I_d and the diode voltage V_d after adjusting the applicable model parameters for temperature.

Applicable Range of V_d Values	Corresponding I_d Equation
$V_d > 80 * V_t$	$I_d = IS \left(\left(\frac{V_d}{V_t} - 79 \right) e^{80} - 1 \right) + V_d * G \text{ min}$
$80 * V_t \geq V_d \geq -3 * V_t$	$I_d = IS * (e^{V_d/V_t} - 1) + V_d * G \text{ min}$

Applicable Range of V_d Values	Corresponding I_d Equation
$-3 * V_t > V_d \geq -BV$	$I_d = -IS \left(1 + \frac{27}{(V_d / V_t)^3 e^3} \right) + V_d * G \text{ min}$
$V_d < -BV$	$I_d = -IBV * \left(e^{-(BV+V_d)/V_t} - 1 \right) -$ $IS * \left(1 - \left(\frac{3}{e * BV / V_t} \right)^3 \right) + V_d * G \text{ min}$

Where:

- IS is the **Saturation current**, **IS** parameter value.
- $V_t = N * k * T / q$
- N is the **Emission coefficient**, **ND** parameter value.
- q is the elementary charge on an electron.
- k is the Boltzmann constant.
- T is the diode temperature:
 - If you select Device temperature for the **Model temperature dependence using** parameter, T is the sum of the **Circuit temperature** value plus the **Offset local circuit temperature**, **TOFFSET** parameter value. The **Circuit temperature** value comes from the SPICE Environment Parameters block, if one exists in the circuit. Otherwise, it comes from the default value for this block.

Diode (SPICE)

- If you select Fixed temperature for the **Model temperature dependence using** parameter, T is the **Fixed circuit temperature**, **TFIXED** parameter value.
- $GMIN$ is the diode minimum conductance. By default, $GMIN$ matches the **Minimum conductance GMIN** parameter of the SPICE Environment Parameters block, whose default value is $1e-12$. To change $GMIN$, add a SPICE Environment Parameters block to your model and set the **Minimum conductance GMIN** parameter to the desired value.
- BV is the **Reverse breakdown voltage**, **BV** parameter value.

Junction Charge Model

The block provides the following relationship between the diode charge Q_d and the diode voltage V_d after adjusting the applicable model parameters for temperature.

Applicable Range of V_d Values	Corresponding Q_d Equation
$V_d < FC * VJ$	$Q_d = TT * I_d + CJO * VJ * \frac{1 - \left(1 - \frac{V_d}{VJ}\right)^{1-MG}}{1-MG}$
$V_d \geq FC * VJ$	$Q_d = TT * I_d + CJO * \left(F1 + \frac{F3 * (V_d - FC * VJ) + \left(\frac{MG}{2 * VJ}\right) * (V_d^2 - (FC * VJ)^2)}{F2} \right)$

Where:

- FC is the **Capacitance coefficient FC** parameter value.
- VJ is the **Junction potential VJ** parameter value.
- TT is the **Transit time, TT** parameter value.
- $CJ0$ is the **Zero-bias junction capacitance CJ0** parameter value.
- MG is the **Grading coefficient MG** parameter value.
- $F1 = VJ * (1 - (1 - FC)^{(1-MG)}) / (1 - MG)$
- $F2 = (1 - FC)^{(1+MG)}$
- $F3 = 1 - FC * (1 + MG)$

Temperature Dependence

Several diode parameters depend on temperature. There are two ways to specify the diode temperature:

- When you select `Device` temperature for the **Model temperature dependence using** parameter, the diode temperature is

$$T = T_C + T_O$$

where:

- T_C is the **Circuit temperature** parameter value from the SPICE Environment Parameters block. If this block doesn't exist in the circuit, T_C is the default value of this parameter.
- T_O is the **Offset local circuit temperature, TOFFSET** parameter value.
- When you select `Fixed` temperature for the **Model temperature dependence using** parameter, the diode temperature is the **Fixed circuit temperature, TFIXED** parameter value.

The block provides the following relationship between the saturation current IS and the diode temperature T :

Diode (SPICE)

$$IS(T) = IS * (T/T_{meas})^{\frac{XTI}{ND}} * e^{\left(\frac{T}{T_{meas}} - 1\right) * \frac{EG}{V_t}}$$

where:

- IS is the **Transport saturation current, IS** parameter value.
- T_{meas} is the **Parameter extraction temperature, TMEAS** parameter value.
- XTI is the **Saturation current temperature exponent, XTI** parameter value.
- ND is the **Emission coefficient, ND** parameter value.
- EG is the **Activation energy, EG** parameter value.
- $V_t = kT/q$.

The block provides the following relationship between the junction potential VJ and the diode temperature T :

$$VJ(T) = VJ * \left(\frac{T}{T_{meas}}\right) - \frac{3 * k * T}{q} * \log\left(\frac{T}{T_{meas}}\right) - \left(\frac{T}{T_{meas}}\right) * EG_{T_{meas}} + EG_T$$

where:

- VJ is the **Junction potential, VJ** parameter value.
- $EG_{T_{meas}} = 1.16eV - (7.02e - 4 * T_{meas}^2) / (T_{meas} + 1108)$
- $EG_T = 1.16eV - (7.02e - 4 * T^2) / (T + 1108)$

The block provides the following relationship between the junction capacitance CJO and the diode temperature T :

$$CJO(T) = CJO * \left[1 + MJ * \left(400e^{-6 * (T - T_{meas})} - \frac{VJ(T) - VJ}{VJ} \right) \right]$$

where CJO is the **Zero-bias junction capacitance CJO** parameter value.

Basic Assumptions and Limitations

The model is based on the following assumptions:

- The Diode block does not support noise analysis.
- The Diode block applies initial conditions across junction capacitors and not across the block ports.

Diode (SPICE)

Dialog Box and Parameters

Main Tab

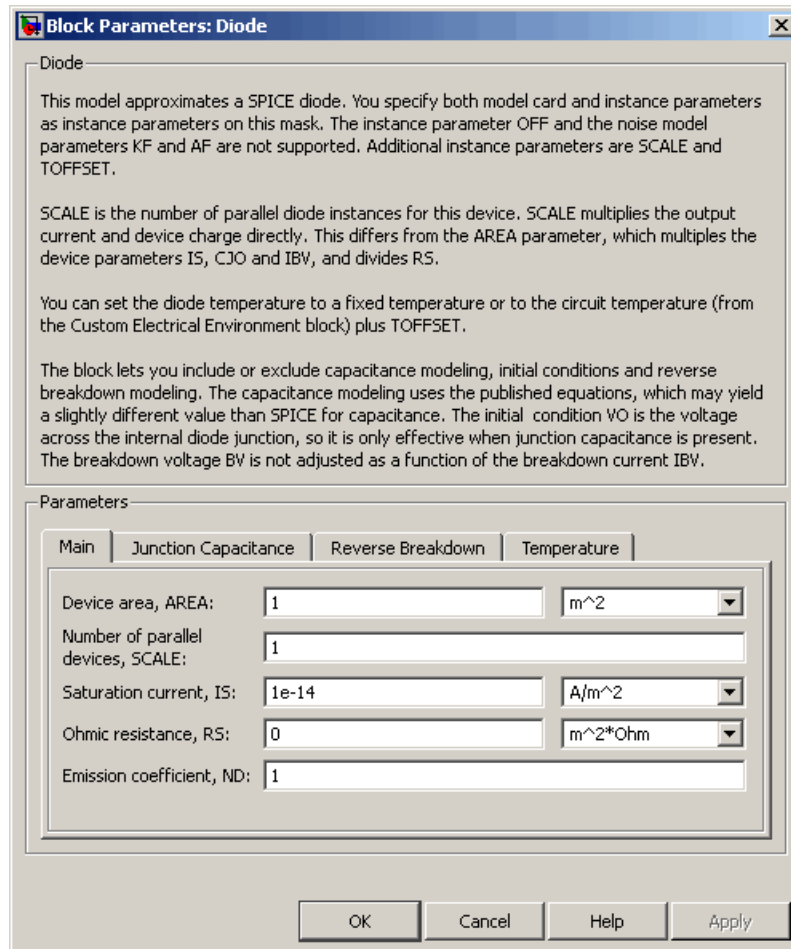

Device area, AREA

The diode area. This value multiplies the **Saturation current, IS**, **Zero-bias junction capacitance CJO**, and **Reverse breakdown current, IBV** parameter values. It divides the

Ohmic resistance, RS parameter value. The default value is 1 m². The value must be greater than 0.

Number of parallel devices, SCALE

The number of parallel diodes the block represents. This value multiplies the output current and device charges. The default value is 1. The value must be greater than 0.

Saturation current, IS

The magnitude of the current that the ideal diode equation approaches asymptotically for very large reverse bias levels. The default value is 1e-14 A/m². The value must be greater than or equal to 0.

Ohmic resistance, RS

The series diode connection resistance. The default value is 0 m²*Ω. The value must be greater than or equal to 0.

Emission coefficient, ND

The diode emission coefficient or ideality factor. The default value is 1. The value must be greater than 0.

Diode (SPICE)

Junction Capacitance Tab

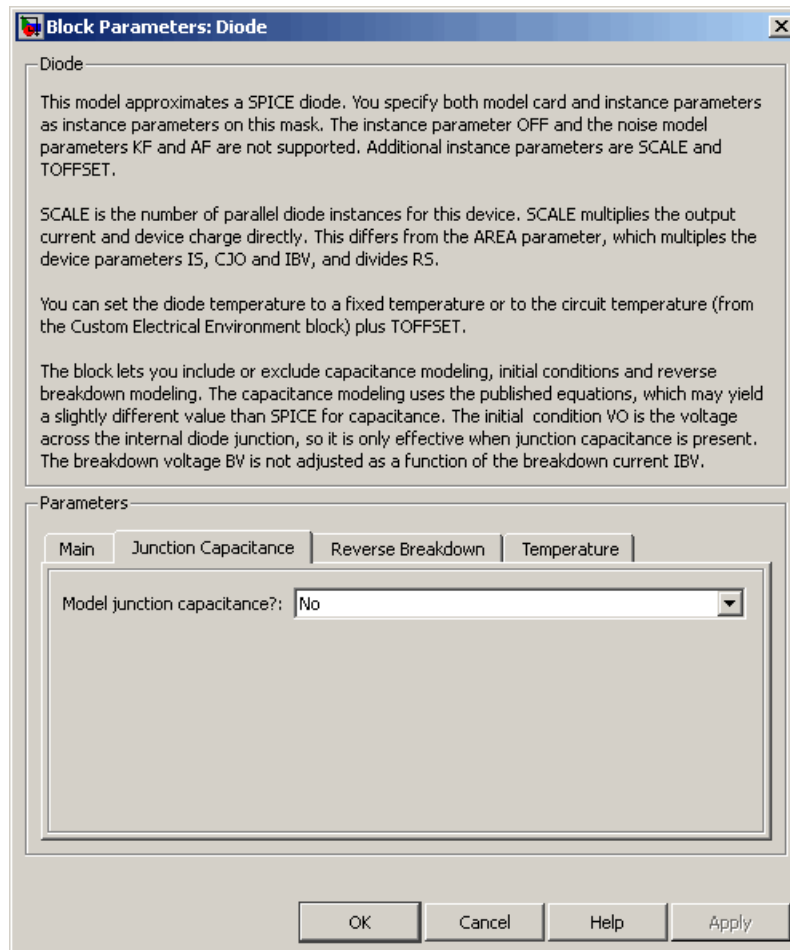

Model junction capacitance

Select one of the following options for modeling the junction capacitance:

- **No** — Do not include junction capacitance in the model. This is the default option.
- **Yes** — Specify zero-bias junction capacitance, junction potential, grading coefficient, forward-bias depletion capacitance coefficient, and transit time.

Zero-bias junction capacitance CJO

The value of the capacitance placed in parallel with the exponential diode term. This parameter is only visible when you select **Yes** for the **Model junction capacitance** parameter. The default value is 0 F/m². The value must be greater than or equal to 0.

Junction potential VJ

The junction potential. This parameter is only visible when you select **Yes** for the **Model junction capacitance** parameter. The default value is 1 V. The value must be greater than 0.01 V.

Grading coefficient MG

The grading coefficient. This parameter is only visible when you select **Yes** for the **Model junction capacitance** parameter. The default value is 0.5. The value must be greater than 0 and less than 0.9.

Capacitance coefficient FC

The fitting coefficient that quantifies the decrease of the depletion capacitance with applied voltage. This parameter is only visible when you select **Yes** for the **Model junction capacitance** parameter. The default value is 0.5. The value must be greater than or equal to 0 and less than 0.95.

Transit time, TT

The transit time of the minority carriers that cause diffusion capacitance. This parameter is only visible when you select **Yes** for the **Model junction capacitance** parameter. The default value is 0 s. The value must be greater than or equal to 0.

Diode (SPICE)

Specify initial condition

Select one of the following options for specifying an initial condition:

- No — Do not specify an initial condition for the model. This is the default option.
- Yes — Specify the initial diode voltage.

Note The Diode block applies the initial diode voltage across the junction capacitors and not across the ports.

Initial voltage V0

Diode voltage at the start of the simulation. This parameter is only visible when you select **Yes** for the **Model junction capacitance** and **Yes** for the **Specify initial condition** parameter. The default value is 0 V.

Note The block applies the initial condition across the diode junction, so the initial condition is only effective when charge storage is included, i.e. when one or both of the **Zero-bias junction capacitance CJO** and **Transit time, TT** parameters are greater than zero.

Reverse Breakdown Tab

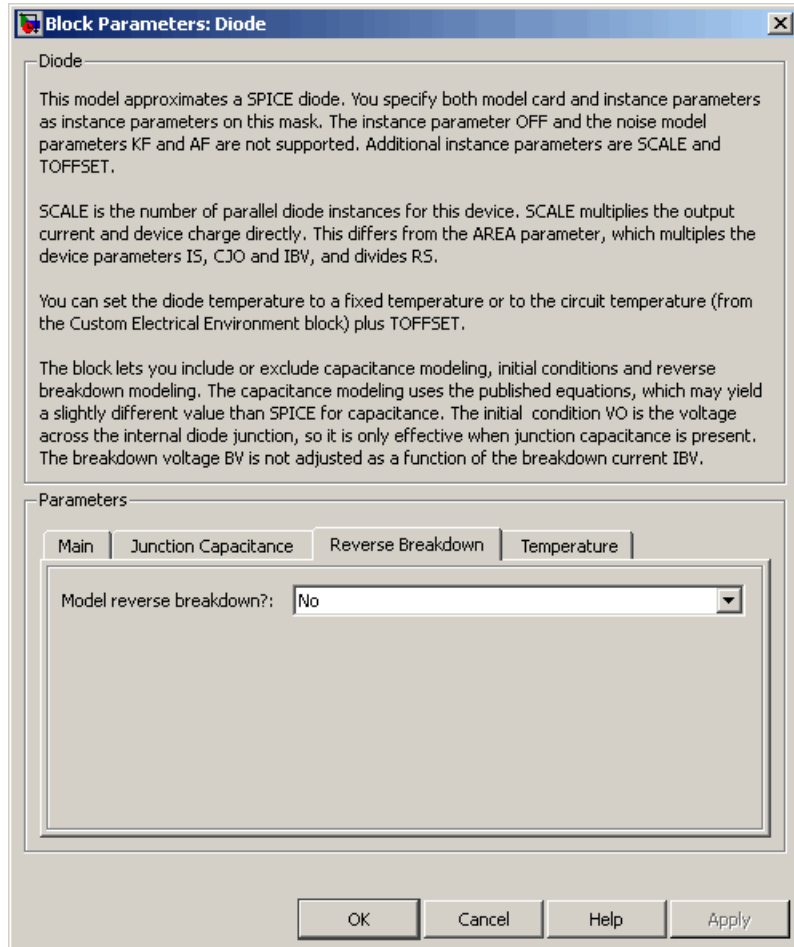

Model reverse breakdown

Select one of the following options for modeling the diode reverse breakdown:

Diode (SPICE)

- No — Don't model reverse breakdown. This is the default option.
- Yes — Introduce a second exponential term to the diode I-V relationship, thereby modeling a rapid increase in conductance as the breakdown voltage is exceeded.

Reverse breakdown current, IBV

The diode current that corresponds to the **Reverse breakdown voltage, BV** value. This parameter is only visible when you select Yes for the **Model reverse breakdown** parameter. The default value is 0.001 A/m₂. The value must be greater than 0.

Note The Diode model does not use this parameter at this time.

Reverse breakdown voltage, BV

The voltage below which to model the rapid increase in conductance that occurs at diode breakdown. This parameter is only visible when you select Yes for the **Model reverse breakdown** parameter. The default value is Inf V. The value must be greater than or equal to 0.

Temperature Tab

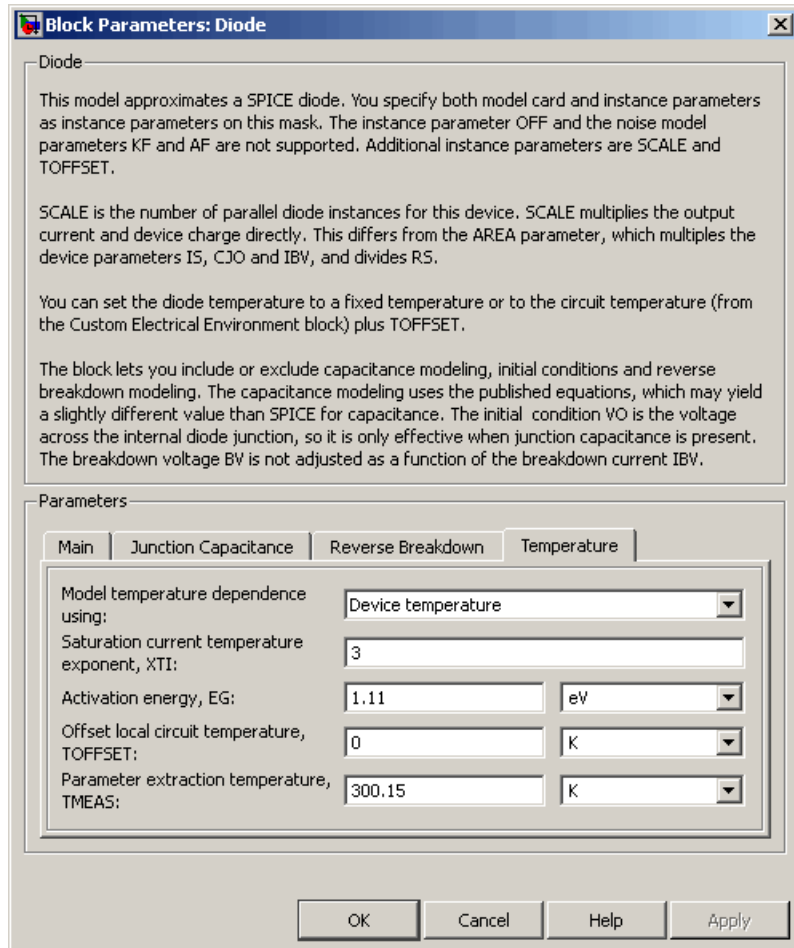

Model temperature dependence using

Select one of the following options for modeling the diode temperature dependence:

Diode (SPICE)

- **Device temperature** — Use the device temperature, which is the **Circuit temperature** parameter value (from the SPICE Environment Parameters block, if one exists in the circuit, or the default value for this block otherwise) plus the **Offset local circuit temperature, TOFFSET** parameter value.
- **Fixed temperature** — Use a temperature that is independent of the circuit temperature to model temperature dependence.

Saturation current temperature exponent, XTI

The order of the exponential increase in the saturation current as temperature increases. This parameter is only visible when you select **Device temperature** for the **Model temperature dependence using** parameter. The default value is 3. The value must be greater than 0.

Activation energy, EG

The diode activation energy. This parameter is only visible when you select **Device temperature** for the **Model temperature dependence using** parameter. The default value is 1.11 eV. The value must be greater than or equal to 0.1.

Offset local circuit temperature, TOFFSET

The amount by which the diode temperature differs from the circuit temperature. This parameter is only visible when you select **Device temperature** for the **Model temperature dependence using** parameter. The default value is 0 K.

Parameter extraction temperature, TMEAS

The temperature at which the diode parameters were measured. The default value is 300.15 K. The value must be greater than 0.

Fixed circuit temperature, TFIXED

The temperature at which to simulate the diode. This parameter is only visible when you select **Fixed temperature** for the **Model temperature dependence using** parameter. The default value is 300.15 K. The value must be greater than 0.

Ports

The block has the following ports:

+ Positive electrical voltage.

- Negative electrical voltage.

See Also

Diode

Exponential Current Source

Purpose Model exponential pulse current source

Library SPICE-Compatible Sources

Description



Exponential Current Source

The Exponential Current Source block represents a current source whose output current value is an exponential pulse as a function of time and is independent of the voltage across the terminals of the source. The following equations describe the current through the source as a function of time:

$$I_{out}(0 \leq Time \leq TDR) = I1$$

$$I_{out}(TDR < Time \leq TDF) = I1 + (I2 - I1) * (1 - e^{-(Time-TDR)/TR})$$

$$I_{out}(TDF < Time) = I1 + (I2 - I1) * (e^{-(Time-TDF)/TF} - e^{-(Time-TDR)/TR})$$

where:

- $I1$ is the **Initial value**, **I1** parameter value.
- $I2$ is the **Pulse value**, **I2** parameter value.
- TDR is the **Rise delay time**, **TDR** parameter value.
- TR is the **Rise time**, **TR** parameter value.
- TDF is the **Fall delay time**, **TDF** parameter value.
- TF is the **Fall time**, **TF** parameter value.

The block uses a small conductance internally to prevent numerical simulation issues. The conductance connects the + and - ports of the device and has a conductance $GMIN$:

- By default, *GMIN* matches the **Minimum conductance GMIN** parameter of the SPICE Environment Parameters block, whose default value is $1e-12$.
- To change *GMIN*, add a SPICE Environment Parameters block to your model and set the **Minimum conductance GMIN** parameter to the desired value.

Dialog Box and Parameters

Block Parameters: Exponential Current Source

Exponential Current Source

The Exponential Current Source block maintains an exponential current through its terminals, independent of the voltage across its terminals. The following equations describe the current through the exponential source as a function of time:

$$I_{out}(0 \leq \text{Time} \leq \text{TDR}) = I_1$$
$$I_{out}(\text{TDR} < \text{Time} \leq \text{TDF}) = I_1 + (I_2 - I_1) * (1 - \exp(-(\text{Time} - \text{TDR}) / \text{TR}))$$
$$I_{out}(\text{TDF} < \text{Time}) = I_1 + (I_2 - I_1) * (1 - \exp(-(\text{Time} - \text{TDR}) / \text{TR})) + (I_1 - I_2) * (1 - \exp(-(\text{Time} - \text{TDF}) / \text{TF}))$$

TR is the rise time. TF is the fall time. TDR is the rise time delay. TDF is the fall time delay. The default values for TR, TF and TDF differ from SPICE. The default rise and fall times are one nanosecond ($1e-9$), and the values of TR and TF must be greater than zero. The default value for the fall delay time is zero. If TDF is less than TDR, the middle equation above is not used.

Parameters

Initial value, I1:	<input type="text" value="0"/>	A
Pulse value, I2:	<input type="text" value="0"/>	A
Rise delay time, TDR:	<input type="text" value="0"/>	s
Rise time, TR:	<input type="text" value="1e-09"/>	s
Fall delay time, TDF:	<input type="text" value="0"/>	s
Fall time, TF:	<input type="text" value="1e-09"/>	s

OK Cancel Help Apply

Exponential Current Source

Initial value, I1

The value of the output current at time zero. The default value is 0 A.

Pulse value, I2

The asymptotic value of the output current when the output is high. The default value is 0 A.

Rise delay time, TDR

The rise time delay. The default value is 0 s.

Rise time, TR

The time it takes the output current to rise from the **Initial Value, I1** value to the **Pulse Value, I2** value. The default value is 1e-09 s. The value must be greater than 0.

Fall delay time, TDR

The fall time delay. The default value is 0 s, which differs from the SPICE default value.

Fall time, TF

The time it takes the output current to fall from the **Pulse value, I2** value to the **Initial value, I1** value. The default value is 1e-09 s. The value must be greater than 0.

Ports

The block has the following ports:

+

Positive electrical voltage.

-

Negative electrical voltage.

See Also

Exponential Voltage Source

Purpose Model exponential pulse voltage source

Library SPICE-Compatible Sources

Description

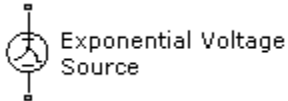

The Exponential Voltage Source block represents a voltage source whose output voltage value is an exponential pulse as a function of time and is independent of the current through the source. The following equations describe the output current as a function of time:

$$V_{out}(0 \leq Time \leq TDR) = V1$$

$$V_{out}(TDR < Time \leq TDF) = V1 + (V2 - V1) * (1 - e^{-(Time-TDR)/TR})$$

$$V_{out}(TDF < Time) = V1 + (V2 - V1) * (e^{-(Time-TDF)/TF} - e^{-(Time-TDR)/TR})$$

where:

- $V1$ is the **Initial value**, **V1** parameter value.
- $V2$ is the **Pulse value**, **V2** parameter value.
- TDR is the **Rise delay time**, **TDR** parameter value.
- TR is the **Rise time**, **TR** parameter value.
- TDF is the **Fall delay time**, **TDF** parameter value.
- TF is the **Fall time**, **TF** parameter value.

Exponential Voltage Source

Dialog Box and Parameters

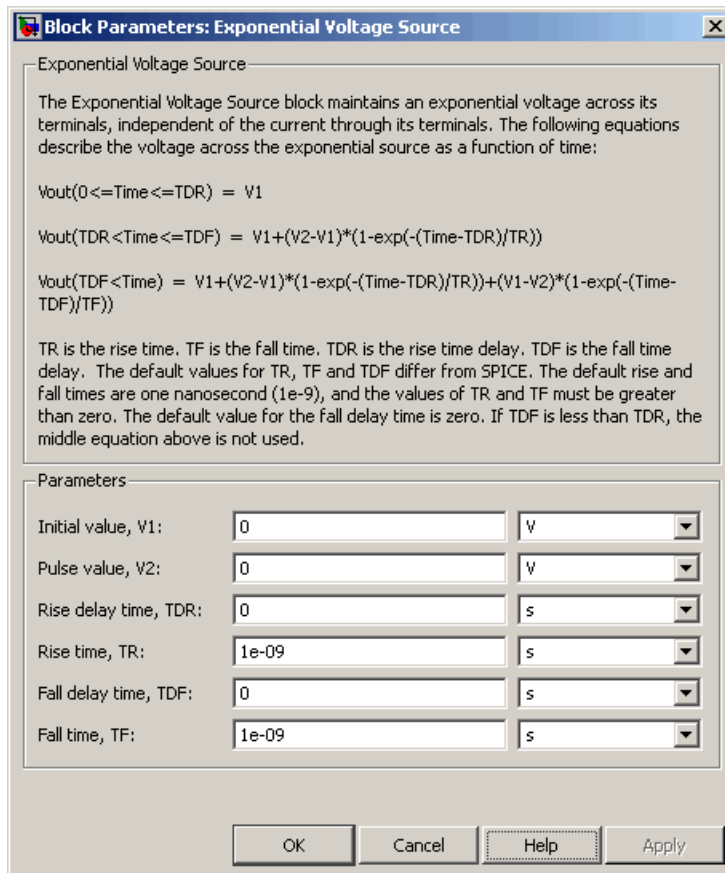

Initial value, V1

The value of the output voltage at time zero. The default value is 0 V.

Pulse value, V2

The asymptotic value of the output voltage when the output is high. The default value is 0 V.

Rise delay time, TDR

The rise time delay. The default value is 0 s.

Rise time, TR

The time it takes the output voltage to rise from the **Initial value, I1** value to the **Pulse value, I2** value. The default value is 1e-09 s. The value must be greater than 0.

Fall delay time, TDR

The fall time delay. The default value is 0 s.

Fall Time, TF

The time it takes the output voltage to fall from the **Pulse value, I2** value to the **Initial value, I1** value. The default value is 1e-09 s. The value must be greater than 0.

Ports

The block has the following ports:

+

Positive electrical voltage.

-

Negative electrical voltage.

See Also

Exponential Current Source

Finite-Gain Op-Amp

Purpose Model gain-limited operational amplifier

Library Integrated Circuits

Description



Finite Gain Op-Amp

The Finite-Gain Op-Amp block models a gain-limited operational amplifier. If the voltages at the positive and negative ports are V_p and V_m , respectively, the output voltage is:

$$V_{out} = A(V_p - V_m) - I_{out} * R_{out}$$

where:

- A is the gain.
- R_{out} is the output resistance.
- I_{out} is the output current.

The input current is:

$$\frac{V_p - V_m}{R_{in}}$$

where R_{in} is the input resistance.

The output voltage is limited by the minimum and maximum output values you specify in the block dialog box.

Dialog Box and Parameters

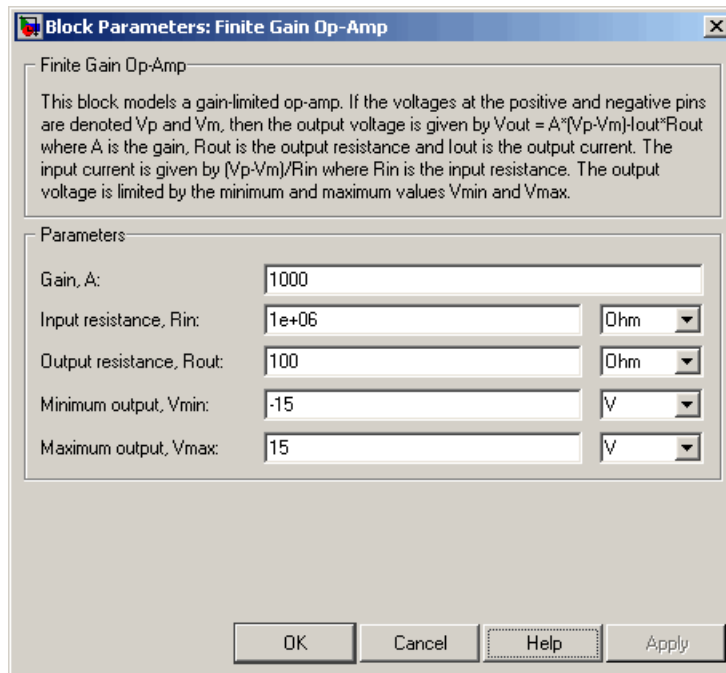

Gain, A

The open-loop gain of the operational amplifier. The default value is 1000.

Input resistance, R_{in}

The resistance at the input of the operational amplifier that the block uses to calculate the input current. The default value is $1e+06 \Omega$.

Output resistance, R_{out}

The resistance at the output of the operational amplifier that the block uses to calculate the drop in output voltage due to output current. The default value is 100Ω .

Finite-Gain Op-Amp

Minimum output, V_{min}

The lower limit on the operational amplifier output voltage. The default value is -15 V.

Maximum output, V_{max}

The upper limit on the operational amplifier output voltage. The default value is 15 V.

Ports

The block has the following ports:

+

Positive electrical voltage.

-

Negative electrical voltage.

OUT

Output voltage.

See Also

Simscape Op-Amp, Band-Limited Op-Amp

Purpose Model fuse that protects against excessive current

Library Passive Devices

Description



Fuse

The Fuse block breaks the circuit in which it is connected. It does so when the current through the device exceeds the rated current at which the fuse is designed to blow and continues to exceed it for a specified amount of time.

Dialog Box and Parameters

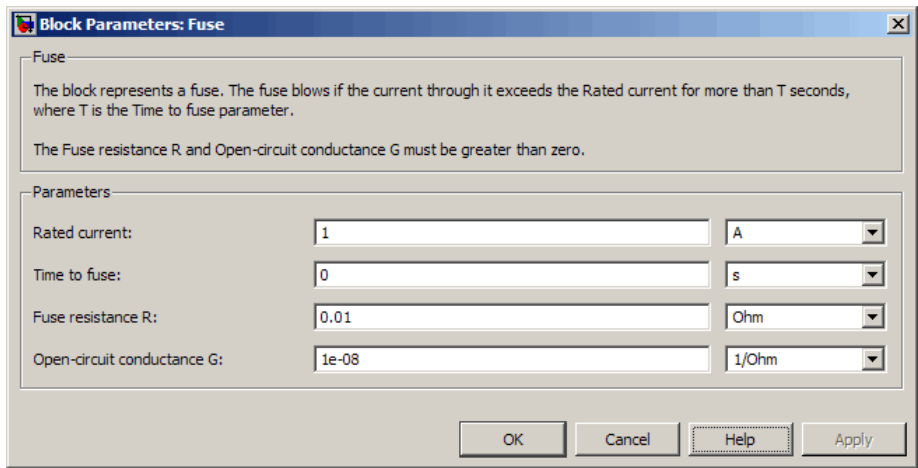

Rated current

The current value at which the fuse blows when exceeded for a specified amount of time. The default value is 1 A.

Time to fuse

The time for which the current must exceed the rated current for the fuse to blow. The default value is 0 s.

Fuse resistance R

The fuse resistance. The parameter value must be greater than zero. The default value is 0.01 Ω.

Open-circuit conductance G

The open-circuit fuse conductance when the fuse has blown. The parameter value must be greater than zero. The default value is $1e-08$ $1/\Omega$.

Ports

The block has the following ports:

- + Positive electrical port.
- Negative electrical port.

Purpose Model simple battery

Library Sources

Description



Generic Battery

The Generic Battery block represents a simple battery. If you select **Infinite** for the **Battery charge capacity** parameter, the block models the battery as a series resistor and a constant voltage source. If you select **Finite** for the **Battery charge capacity** parameter, the block models the battery as a series resistor and a charge-dependent voltage source whose voltage as a function of charge has the following reciprocal relationship:

$$V = V_0 \left[1 - \left(\frac{\alpha(1-x)}{1-\beta(1-x)} \right) \right]$$

where:

- x is the ratio of the ampere-hours left to the number of ampere-hours, AH , for which the battery is rated.
- V_0 is the voltage when the battery is fully charged, as defined by the **Nominal voltage, V_nominal** parameter.
- The block calculates the constants α and β to satisfy the following battery conditions:
 - The battery voltage is zero when the charge is zero, that is, when $x = 0$.
 - The battery voltage is $V1$ (the **Voltage V1 < V_nominal when charge is AH1** parameter value) when the charge is the **Charge AH1 when no-load volts are V1** parameter value, that is, when $x = AH1/AH$.

Generic Battery

Dialog Box and Parameters

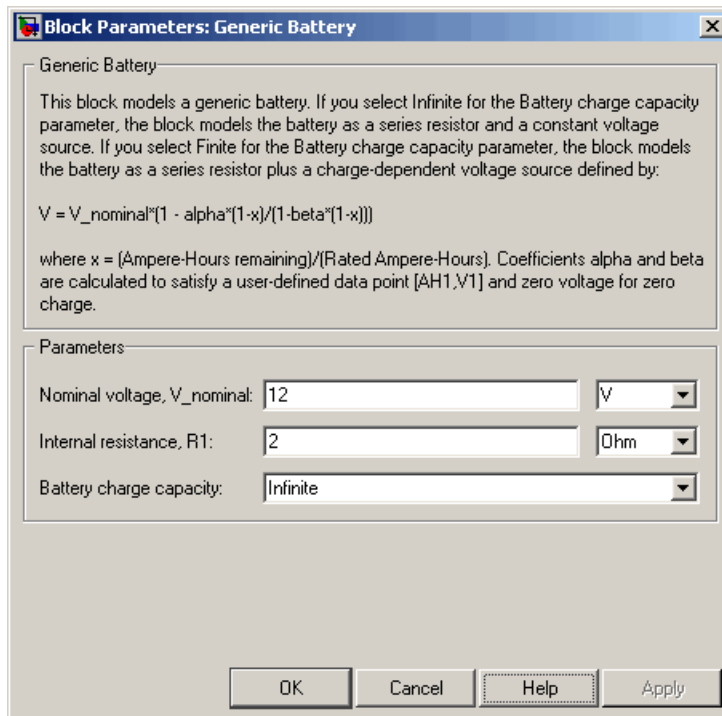

Nominal voltage, V_nominal

The voltage at the output port when the battery is fully charged. The default value is 12 V.

Internal resistance, R1

Internal connection resistance. The default value is 2 Ω.

Battery charge capacity

Select one of the following options for modeling the charge capacity of the battery:

- **Infinite** — The battery voltage is independent of charge drawn from the battery. This is the default option.
- **Finite** — The battery voltage decreases as charge decreases.

Ampere-Hour rating, AH

The maximum battery charge in ampere-hours. This parameter is only visible when you select `Finite` for the **Battery charge capacity** parameter. The default value is 50 hr*A.

Initial charge

The battery charge at the start of the simulation. This parameter is only visible when you select `Finite` for the **Battery charge capacity** parameter. The default value is 50 hr*A.

Voltage V1 < V_nominal when charge is AH1

The battery output voltage when the charge level is AH1 hr*A. This parameter is only visible when you select `Finite` for the **Battery charge capacity** parameter. The default value is 11.5 V.

Charge AH1 when no-load volts are V1

The battery charge level in hr*A when the no-load output voltage is V1. This parameter is only visible when you select `Finite` for the **Battery charge capacity** parameter. The default value is 25 hr*A.

Self-discharge resistance, R2

Select one of the following options for modeling the self-discharge resistance of the battery:

- `Omit` — Do not include resistance across the battery output terminals in the model.
- `Include` — Include resistance R2 across the battery output terminals in the model.

R2

The resistance across the battery output terminals that represents battery self-discharge. This parameter is only visible when you select `Include` for the **Self-discharge resistance, R2** parameter. The default value is 2e+03 Ω.

Ports

The block has the following ports:

Generic Battery

+ Positive electrical voltage.

- Negative electrical voltage.

See Also Simscape DC Voltage Source, Simscape Controlled Voltage Source

Purpose

Model generic linear actuator driven from DC voltage source or PWM driver

Library

Actuators & Drivers

Description

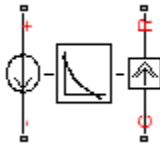

Generic Linear Actuator

The Generic Linear Actuator block implements a model of a generic linear actuator designed to be driven from a DC voltage source or a PWM driver. Define force-speed characteristics in terms of tabulated values for powering the motor at the rated voltage. This functionality enables you to model a motor without referencing an equivalent circuit.

The motor or actuator architecture determines the way in which electrical losses depend on force. For example, a DC motor has losses that are proportional to the square of the current. As force is proportional to current, losses are also proportional to mechanical force. Most motors have an electrical loss term that is proportional to the square of mechanical force. The Generic Linear Actuator block calculates this loss term using the **Motor efficiency (percent)** and **Speed at which efficiency is measured** parameters that you provide.

Some motors also have a loss term that is independent of force. An example is a shunt motor where the field winding draws a constant current regardless of load. The **Force-independent electrical losses** parameter accounts for this effect.

The motor efficiency is the mechanical power divided by the sum of the mechanical power and both electrical loss terms. The block assumes that the speed at which the motor efficiency is defined is in the motoring quadrant and, therefore, positive.

Generic Linear Actuator

You can operate the block in the reverse direction by changing the sign of the voltage applied. The H-Bridge block, for example, reverses motor direction if the voltage at the REV port is greater than the **Reverse threshold voltage** parameter. However, if you are using the block in reverse, specify the force-speed data for forward operation:

- Positive forces and positive speeds in the motoring quadrant.
- Positive force and negative speeds in the generating counterclockwise quadrant.
- Negative force and positive speed in the generating clockwise quadrant.

Basic Assumptions and Limitations

This block has the following limitations:

- The force-speed curve data corresponds only to the rated voltage, so the block produces accurate results only when driven by plus or minus the rated voltage.
- The block requires you to provide force-speed data for the full range over which you use the actuator. To use the actuator in the generating and braking regions, provide additional data outside of the normal motoring region.
- Model behavior is sensitive to force-speed data. For example, no-load speed is correctly defined and finite only when the data crosses the speed axis.
- To drive the block from the H-Bridge block:
 - Do not place any other blocks between the H-Bridge and the Generic Linear Actuator blocks.
 - In the H-Bridge block dialog box, set the **Freewheeling mode** to **Via one semiconductor switch and one freewheeling diode**. Selecting **Via two freewheeling diodes** does not set the bridge output voltage to zero when the PWM input signal is low.

- In the H-Bridge, Generic Rotary Actuator, and Controlled PWM block dialog boxes, ensure that the **Simulation mode** is the same for all three blocks.

Dialog Box and Parameters

Electrical Force Tab

Block Parameters: Generic Linear Actuator

Generic Linear Actuator

This block implements a model of generic linear actuator designed to be driven from a DC voltage source or PWM driver. The force-speed characteristics are defined in terms of tabulated values for when the motor is powered at the rated voltage. The block can be driven in PWM or Averaged mode. In PWM mode, the applied voltage should either be the rated supply voltage, or a PWM voltage with amplitude equal to the rated supply voltage. In Averaged mode, the applied voltage should be the rated supply voltage multiplied by the fraction of the PWM period for which the motor is powered. If driving the block with the H-Bridge block, the Simulation mode parameter value must be the same for both blocks and also for the Controlled PWM Voltage block if used.

Electrical losses are assumed to be the sum of a force-independent term plus a term proportional to the square of the force.

Parameters

Electrical Force | Mechanical

Speed values: [-15 -10 -5 0 5 10 15 20 25 30] m/s

Force values: [4 3.5 3 2.5 2 1.5 1 0.5 0 -0.5] N

Rated voltage: 12 V

Motor efficiency (percent): 70

Speed at which efficiency is measured: 20 m/s

Force-independent electrical losses: 2 W

Simulation mode: PWM

OK Cancel Help Apply

Speed values

Specify a vector of speeds, including their units, for your force-speed data. The default value is [-15 -10 -5 0 5 10 15 20 25 30] m/s.

Force values

Specify a vector of forces, including their units, for your force-speed data. The default value is [4 3.5 3 2.5 2 1.5 1 0.5 0 -0.5] N.

Generic Linear Actuator

Rated voltage

Indicate the voltage for which the device you are modeling is rated. The default value is 12 V.

Motor efficiency (percent)

Efficiency that the block uses to calculate force-dependent electrical losses. The default value is 70.

Speed at which efficiency is measured

Speed that the block uses to calculate force-dependent electrical losses. The default value is 20 m/s.

Force-independent electrical losses

Fixed electrical loss associated with the actuator when the force is zero. The default value is 2 W.

Simulation mode

If you set the **Simulation mode** parameter to PWM, apply a PWM waveform switching between zero and rated volts to the block electrical terminals. The current drawn from the electrical supply is equal to the amount required to deliver the mechanical power and to compensate for electrical losses. If the applied voltage exceeds the rated voltage, the resultant force scales proportionately. However, applying anything other than the rated voltage can provide unrepresentative results. PWM is the default setting.

If you set the **Simulation mode** parameter to Averaged, the force generated in response to an applied voltage V_{av} is

$$\frac{V_{av}}{V_{rated}} \times F(v)$$

where $F(v)$ is the force value at speed v . The current drawn from the supply is such that the product of the current and V_{av} is equal to the average power that is consumed.

Mechanical Tab

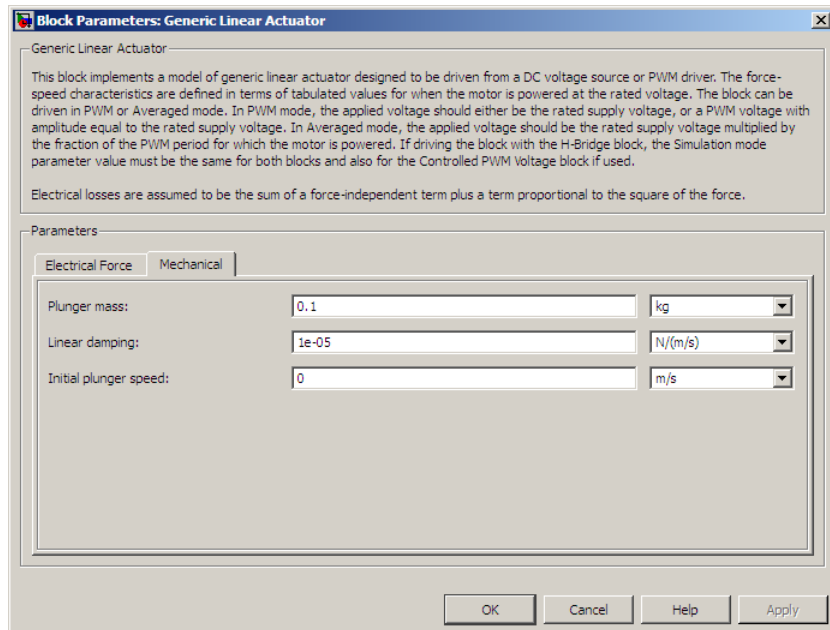

Plunger mass

Mass of the moving part of the motor. The default value is 0.1 kg. The value can be zero.

Linear damping

Linear damping. The default value is 1e-05 N/(m/s). The value can be zero.

Initial plunger speed

Speed of the plunger at the start of the simulation. The default value is 0 m/s.

Ports

This block has the following ports:

Generic Linear Actuator

- + Positive electrical input port.
- Negative electrical input port.
- C Mechanical translational conserving port.
- R Mechanical translational conserving port.

See Also Generic Rotary Actuator and H-Bridge.

Purpose

Model generic rotary actuator driven from DC voltage source or PWM driver

Library

Actuators & Drivers

Description

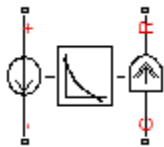

Generic Rotary Actuator

The Generic Rotary Actuator block implements a model of a generic rotary actuator designed to be driven from a DC voltage source or PWM driver. You define torque-speed characteristics in terms of tabulated values for powering the motor at the rated voltage. This functionality allows you to model a motor without referencing an equivalent circuit.

The motor or actuator architecture determines the way in which electrical losses depend on torque. For example, a DC motor has losses that are proportional to the square of the current. As torque is proportional to current, losses are also proportional to mechanical torque. Most motors have an electrical loss term that is proportional to the square of mechanical torque. The Generic Rotary Actuator block calculates this loss term using the **Motor efficiency (percent)** and **Speed at which efficiency is measured** parameters that you provide.

Some motors also have a loss term that is independent of torque. An example is a shunt motor where the field winding draws a constant current regardless of load. The **Torque-independent electrical losses** parameter accounts for this effect.

The motor efficiency is the mechanical power divided by the sum of the mechanical power and both electrical loss terms. The block assumes that the speed at which the motor efficiency is defined is in the motoring quadrant and, therefore, positive.

You can operate the block in the reverse direction by changing the sign of the voltage that you apply. The H-Bridge block, for example, reverses

Generic Rotary Actuator

motor direction if the voltage at the REV port is greater than the **Reverse threshold voltage** parameter. However, if you are using the block in reverse, specify the torque-speed data for forward operation:

- Positive torques and positive speeds in the motoring quadrant.
- Positive torque and negative speeds in the generating counterclockwise quadrant.
- Negative torque and positive speed in the generating clockwise quadrant.

Basic Assumptions and Limitations

This block has the following limitations:

- The torque-speed curve data corresponds only to the rated voltage, so the block produces accurate results only when driven by plus or minus the rated voltage.
- In this block requires, you must provide torque-speed data for the full range over which you use the actuator. To use the actuator in the generating and braking regions, provide additional data outside of the normal motoring region.
- Model behavior is sensitive to torque-speed data. For example, no-load speed is correctly defined and finite only when the data crosses the speed axis.
- To drive the block from the H-Bridge block:
 - Do not place any other blocks between the H-Bridge and the Generic Rotary Actuator blocks.
 - In the H-Bridge block dialog box, set the **Freewheeling mode** to **Via one semiconductor switch and one freewheeling diode**. Selecting **Via two freewheeling diodes** does not set the bridge output voltage to zero when the PWM input signal is low.

- In the H-Bridge, Generic Rotary Actuator, and Controlled PWM block dialog boxes, ensure that the **Simulation mode** is the same for all three blocks.

Dialog Box and Parameters

Electrical Torque Tab

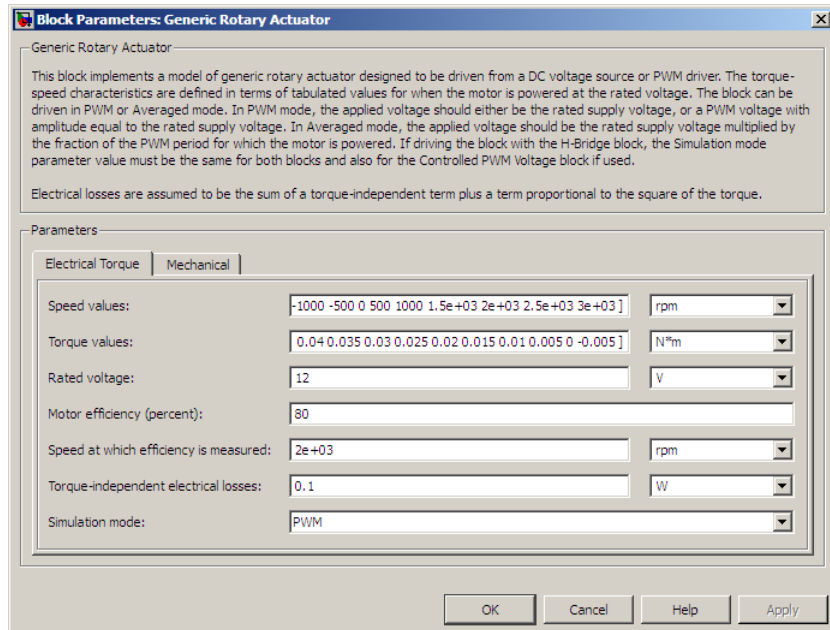

Speed values

Specify a vector of speeds, including their units, for your torque-speed data. The default value is [-1.5e+03 -1000 -500 0 500 1000 1.5e+03 2e+03 2.5e+03 3e+03] rpm.

Torque values

Specify a vector of torques, including their units, for your torque-speed data. The default value is [0.04 0.035 0.03 0.025 0.02 0.015 0.01 0.005 0 -0.005] Nm.

Generic Rotary Actuator

Rated voltage

Indicate the voltage for which the device you are modeling is rated. The default value is 12 V.

Motor efficiency (percent)

The efficiency that the block uses to calculate torque-dependent electrical losses. The default value is 80.

Speed at which efficiency is measured

The speed that the block uses to calculate torque-dependent electrical losses. The default value is 2e+03 rpm.

Torque-independent electrical losses

Fixed electrical loss associated with the actuator when the torque is zero. The default value is 0.1 W.

Simulation mode

If you set the **Simulation mode** parameter to PWM, apply a PWM waveform switching between zero and rated volts to the block electrical terminals. The current drawn from the electrical supply is equal to the amount required to deliver the mechanical power and to compensate for electrical losses. If the applied voltage exceeds the rated voltage, the resultant torque scales proportionately. However, applying anything other than the rated voltage can provide unrepresentative results. PWM is the default setting.

If you set the **Simulation mode** parameter to Averaged, the torque generated in response to an applied voltage V_{av} is

$$\frac{V_{av}}{V_{rated}} \times T(\omega)$$

where $T(\omega)$ is the torque value at speed ω . The current drawn from the supply is such that the product of the current and V_{av} is equal to the average power that is consumed.

Mechanical Tab

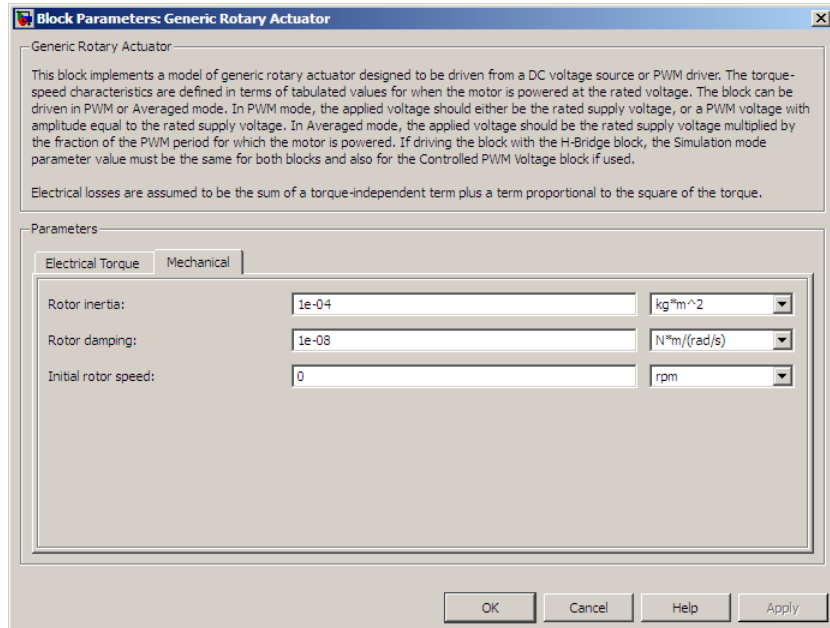

Rotor inertia

Rotor resistance to change in motor motion. The default value is $1e-04 \text{ kg}\cdot\text{m}^2$. The value can be zero.

Rotor damping

Rotor damping. The default value is $1e-08 \text{ N}\cdot\text{m}/(\text{rad}/\text{s})$. The value can be zero.

Initial rotor speed

Speed of the rotor at the start of the simulation. The default value is 0 rpm .

Ports

This block has the following ports:

Generic Rotary Actuator

- + Positive electrical input.
- Negative electrical input.
- C Mechanical rotational conserving port.
- R Mechanical rotational conserving port.

See Also Generic Linear Actuator and H-Bridge.

Purpose Model H-bridge motor driver

Library Actuators & Drivers

Description

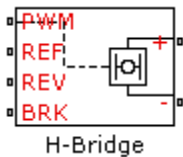

The H-Bridge block represents an H-bridge motor driver. The block has the following two **Simulation mode** options:

- PWM — The H-Bridge output is a controlled voltage that depends on the input signal at the PWM port. If the input signal has a value greater than the **Enable threshold voltage** parameter value, the H-Bridge output is on and has a value equal to the value of the **Output voltage amplitude** parameter. If it has a value less than the **Enable threshold voltage** parameter value, the block maintains the load circuit using one of the following two Freewheeling mode options:

- A freewheeling diode and a semiconductor switch
- Two freewheeling diodes

The signal at the REV port determines the polarity of the output. If the value of the signal at the REV port is less than the value of the **Reverse threshold voltage** parameter, the output has positive polarity; otherwise, it has negative polarity.

- Averaged — The H-Bridge output is:

$$\frac{V_O V_{PWM}}{A_{PWM}} - I_{OUT} R_{ON}$$

Where:

- V_O is the value of the **Output voltage amplitude** parameter.
- V_{PWM} is the value of the voltage at the PWM port.
- A_{PWM} is the value of the **PWM signal amplitude** parameter.
- I_{OUT} is the value of the output current.
- R_{ON} is the **Bridge on resistance** parameter.

H-Bridge

Set the **Simulation mode** parameter to **Averaged** to speed up simulations when driving the H-Bridge block with a Controlled PWM Voltage block. You must also set the **Simulation mode** parameter of the Controlled PWM Voltage block to **Averaged** mode. This applies the average of the demanded PWM voltage to the motor. The **Averaged** mode assumes that the effect of the motor inductive term is small at the **PWM frequency**. To verify this assumption, run the simulation using the **PWM** mode and compare the results to those obtained from using the **Averaged** mode.

Basic Assumptions and Limitations

The model has the following limitations:

- If you are linearizing your model, set the **Simulation mode** parameter to **Averaged** and ensure that you have specified the operating point correctly. You can only linearize the H-Bridge block for inputs that are greater than zero and less than the PWM signal amplitude.

Dialog Box and Parameters

Block Parameters: H-Bridge

H-Bridge

This block represents an H-bridge motor driver.

The block can be driven by the Controlled PWM Voltage block in PWM or Averaged mode. In PWM mode, the motor is powered if the PWM port voltage V is above the Enable threshold voltage. In Averaged mode, the output voltage magnitude is proportional to the PWM port voltage V , reaching a maximum when V is equal to the parameter PWM signal amplitude. The Simulation mode parameter value must be the same for the Controlled PWM Voltage and H-Bridge blocks.

If the REV port voltage is greater than the Reverse threshold voltage, then the output voltage polarity is reversed. If the BRK port voltage is greater than the Braking threshold voltage, then the output terminals are short circuited.

Voltages at ports PWM, REV and BRK are defined relative to the REF port.

Parameters

Enable threshold voltage:	2.5	V
PWM signal amplitude:	5	V
Reverse threshold voltage:	2.5	V
Braking threshold voltage:	2.5	V
Output voltage amplitude:	12	V
Simulation mode:	PWM	
Freewheeling mode:	Via one semiconductor switch and one freewheeling diode	
Total bridge on resistance:	0.1	Ohm
Freewheeling diode on resistance:	0.05	Ohm

OK Cancel Help Apply

Enable threshold voltage

Threshold above which the voltage at the PWM port must rise to enable the H-Bridge output. This parameter is used only when the **Simulation mode** parameter is set to PWM. The default value is 2.5 V.

PWM signal amplitude

The amplitude of the signal at the PWM input. The H-Bridge block uses this parameter only when the **Simulation mode** parameter is set to Averaged. The default value is 5 V.

Reverse threshold voltage

When the voltage at the REV port is greater than this threshold, the output polarity becomes negative. The default value is 2.5 V.

Braking threshold voltage

When the voltage at the BRK port is greater than this threshold, the H-Bridge output terminals are short-circuited via the following series of devices:

- One bridge arm
- One bridge arm in parallel with a conducting freewheeling diode

The default value is 2.5 V.

Output voltage amplitude

The amplitude of the voltage across the H-Bridge output ports when the output is on. The default value is 12 V.

Simulation mode

Select one of the following options for the type of output voltage:

- PWM — The output voltage is a pulse-width modulated signal. This is the default option.
- Averaged — The output voltage is a constant whose value is equal to the average value of the PWM signal.

Freewheeling mode

Select one of the following options for the type of H-Bridge dissipation circuit:

- Via one semiconductor switch and one freewheeling diode — In this mode, the block controls the load by maintaining one high-side bridge arm permanently on and using the PWM signal to modulate the corresponding low-side bridge arm. This means that the block uses only one of the freewheeling diodes in completing the dissipation circuit when the bridge turns off. This option is the default.
- Via two freewheeling diodes — In this mode, all bridge arms are off during the bridge off-state. This means that the

block dissipates the load current across the power supply by two freewheeling diodes.

This parameter is only visible when you select PWM for the **Simulation mode** parameter.

Total bridge on resistance

The total effective resistance of the two semiconductor switches that connect the load to the two power rails when the voltage at the PWM port is greater than the **Enable threshold voltage**. The default value is 0.1 Ω .

Freewheeling diode on resistance

The total resistance in the freewheeling diodes that dissipate the current that flows through the motor when the voltage at the PWM port is less than the **Enable threshold voltage**. This parameter is only visible when you select PWM for the **Simulation mode** parameter. The default value is 0.1 Ω .

Ports

The block has the following ports:

+ref

Positive electrical output voltage.

-ref

Negative electrical output voltage.

PWM

Pulse-width modulated signal. The voltage is defined relative to the REF port.

REF

Floating zero volt reference.

REV

Voltage that controls when to reverse the polarity of the H-Bridge output. The voltage is defined relative to the REF port.

BRK

Voltage that controls when to short circuit the H-Bridge output. The voltage is defined relative to the REF port.

H-Bridge

Examples

See the Controlled DC Motor, Linear Electrical Actuator (System-Level Model) and Linear Electrical Actuator (Implementation Model) demos.

Purpose

Model device that converts information about angular shaft position into electrical pulses

Library

Sensors

Description

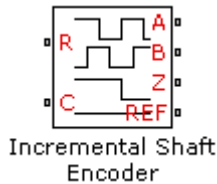

The Incremental Shaft Encoder block represents a device that converts information about the angular position of a shaft into electrical pulses. The block produces N pulses on ports A and B per shaft revolution, where N is the value you specify for the **Pulses per revolution** parameter. Pulses A and B are 90 degrees out of phase. If the shaft rotates in a positive direction, then A leads B. The block produces a single index pulse on port Z once per revolution. The Z pulse positive transition always coincides with an A pulse positive transition. The voltages at output ports A, B, and Z are defined relative to the REF reference port voltage.

Use this block if you need to model the shaft encoder signals, either to support development of a decoding algorithm, or to include the quantization effects. Otherwise, use the Simscape Ideal Rotational Motion Sensor block.

Basic Assumptions and Limitations

The Incremental Shaft Encoder block has the following limitations:

- The Incremental Shaft Encoder block is not linearizable. Use the Simscape Ideal Rotational Motion Sensor block for control design studies where you need to linearize your model.

Incremental Shaft Encoder

Dialog Box and Parameters

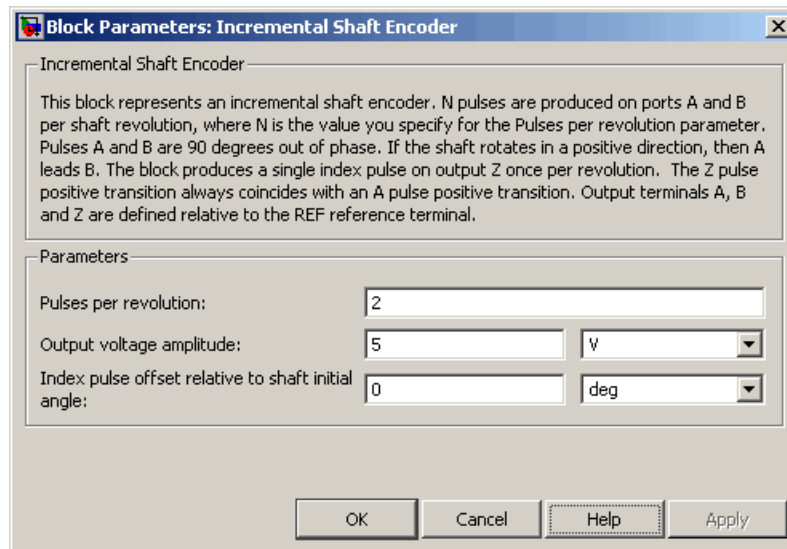

Pulses per revolution

The number of pulses produced on each of the A and B phases per revolution of the shaft. The default value is 2.

Output voltage amplitude

The amplitude of the shaft encoder output voltage when the output is high. The default value is 5 V.

Index pulse offset relative to shaft initial angle

The offset of the index pulse Z relative to the angle of the shaft at the start of the simulation. This parameter lets you set the initial location of the index pulse. The default value is 0°.

Ports

The block has the following ports:

R

Mechanical rotational conserving port associated with the sensor positive probe.

- C Mechanical rotational conserving port associated with the sensor negative (reference) probe.
- A Encoded electrical output.
- B Encoded electrical output.
- Z Index, or synchronization, electrical output.
- REF Floating zero volt reference.

See Also

Simscape Ideal Rotational Motion Sensor

Induction Motor

Purpose Model induction motor powered by ideal AC supply

Library Actuators & Drivers

Description

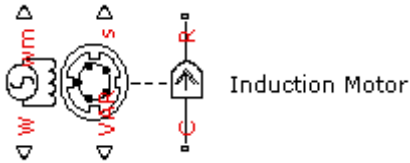

The Induction Motor block represents the electrical and torque characteristics of an induction motor powered by an ideal AC supply. The following figure shows the equivalent circuit model of the Induction Motor block.

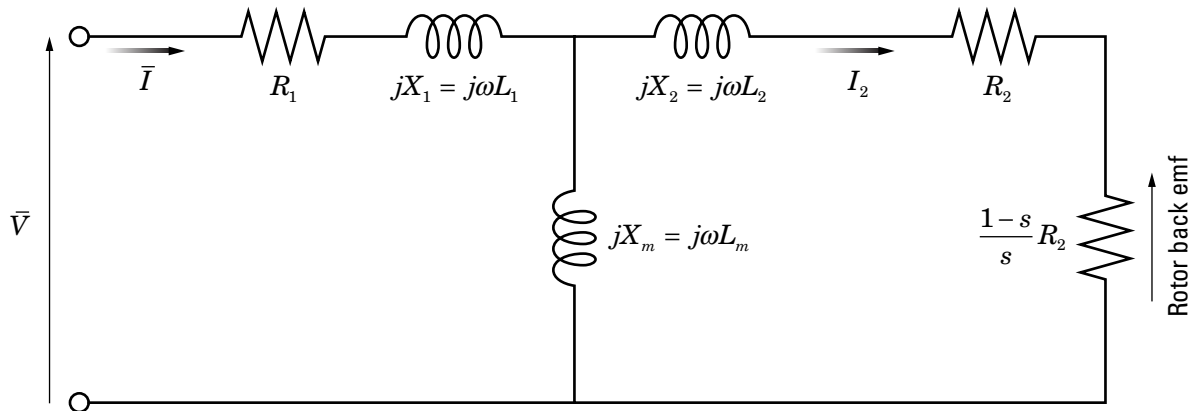

In the figure:

- R_1 is the stator resistance.
- R_2 is the rotor resistance with respect to the stator.
- L_1 is the stator inductance.
- L_2 is the rotor inductance with respect to the stator.

- L_m is magnetizing inductance.
- s is the rotor slip.
- \bar{V} and \bar{I} are the sinusoidal supply voltage and current phasors.

Rotor slip s is defined in terms of the mechanical rotational speed ω_m , the number of pole pairs p , and the electrical supply frequency ω by

$$s = 1 - \frac{p\omega_m}{\omega}$$

This means that the slip is one when starting, and zero when running synchronously with the supply frequency.

For an n -phase induction motor the torque-speed relationship is given by:

$$T = \frac{npR_2}{s\omega} \frac{V_{rms}^2}{\left(R_1 + R_2 + \frac{1-s}{s}R_2\right)^2 + (X_1 + X_2)^2}$$

where:

- V_{rms} is the line-neutral supply voltage for a star-configuration induction motor, and the line-to-line voltage for a delta-configuration induction motor.
- n is the number of phases.

You can parameterize this block in terms of the preceding equivalent circuit model parameters or in terms of the motor ratings the block uses to derive these parameters.

This block produces a positive torque acting from the mechanical C to R ports.

Induction Motor

Basic Assumptions and Limitations

The model is based on the following assumptions:

- The block does not model the starting mechanism for a single-phase induction motor.
- When you parameterize the block by motor ratings, the block derives the equivalent circuit model parameters by assuming that the magnetizing inductance L_m is very large compared to L_1 and L_2 .

Dialog Box and Parameters

Electrical Torque Tab

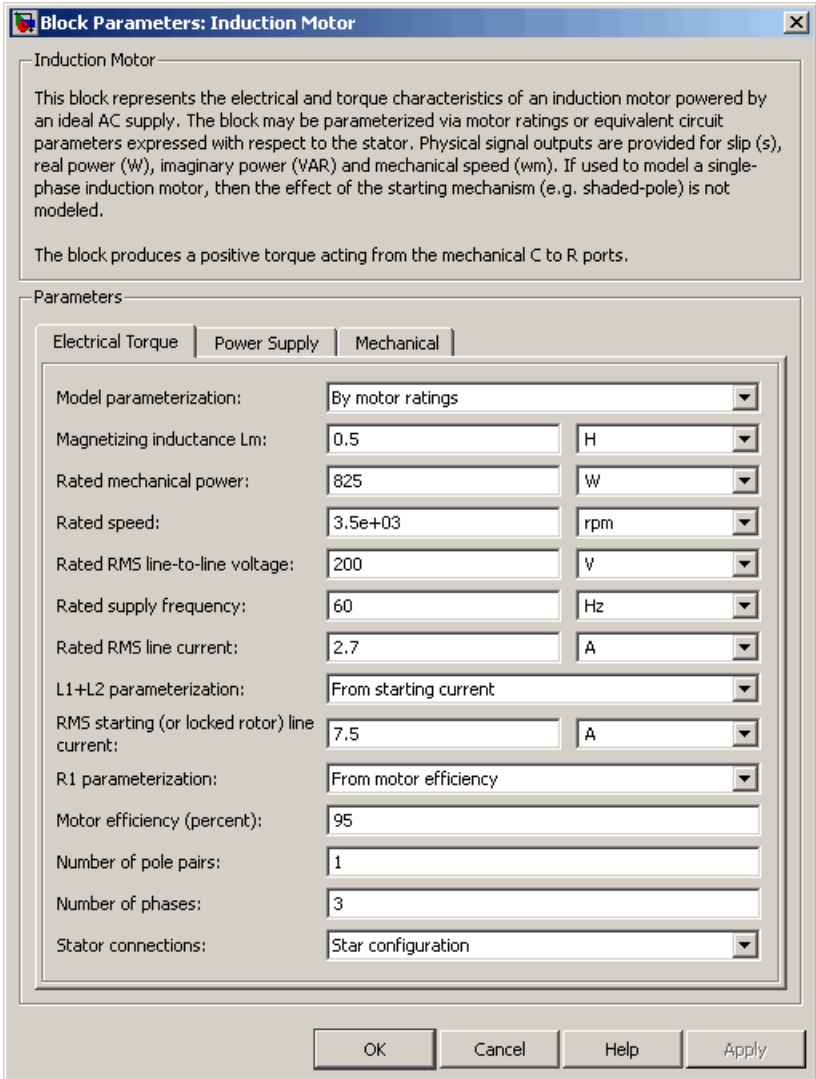

Induction Motor

Model parameterization

Select one of the following methods for block parameterization:

- **By motor ratings** — Provide electrical torque parameters that the block converts to an equivalent circuit model of the motor assuming that the magnetizing inductance is very large compared to L_1 and L_2 . This is the default method.
- **By equivalent circuit parameters** — Provide electrical parameters for an equivalent circuit model of the motor.

Stator resistance R1

Resistance of the stator winding. The default value is 1 Ω . This parameter is only visible when you select **By equivalent circuit parameters** for the **Model parameterization** parameter.

Rotor resistance R2

Resistance of the rotor, specified with respect to the stator. The default value is 1 Ω . This parameter is only visible when you select **By equivalent circuit parameters** for the **Model parameterization** parameter.

Stator inductance L1

Inductance of the stator winding. The default value is 0.02 H. This parameter is only visible when you select **By equivalent circuit parameters** for the **Model parameterization** parameter.

Rotor inductance L2

Inductance of the rotor, specified with respect to the stator. The default value is 0.02 H. This parameter is only visible when you select **By equivalent circuit parameters** for the **Model parameterization** parameter.

Magnetizing inductance Lm

Magnetizing inductance of the stator. Its value is hard to estimate from motor parameters, but the effect is usually small. If you do not know its value, use a typical value of 25 times the **Stator inductance L1** value. The default value is 0.5 H.

Rated mechanical power

Mechanical power the motor delivers when running at the rated speed. The default value is 825 W. This parameter is only visible when you select `By motor ratings` for the **Model parameterization** parameter.

Rated speed

Speed at which the motor delivers the specified **Rated mechanical power** value. The default value is $3.5e+03$ rpm. This parameter is only visible when you select `By motor ratings` for the **Model parameterization** parameter.

Rated RMS line-to-line voltage

Line-to-line voltage at which the motor ratings are specified. The default value is 200 V. This parameter is only visible when you select `By motor ratings` for the **Model parameterization** parameter.

Rated supply frequency

Frequency of the AC supply voltage at which the motor ratings are specified. The default value is 60 hertz. This parameter is only visible when you select `By motor ratings` for the **Model parameterization** parameter.

Rated RMS line current

Line current at which the motor delivers the specified **Rated mechanical power** value. The default value is 2.7 A. This parameter is only visible when you select `By motor ratings` for the **Model parameterization** parameter.

L1+L2 parameterization

Select one of the following parameterizations for the equivalent circuit inductance, L_1+L_2 , of the motor:

- From **starting current** — Estimate the total equivalent circuit inductance from the motor starting current. This is the default method.
- From **maximum torque** — Estimate the total equivalent circuit inductance from the motor maximum torque.

Induction Motor

This parameter is only visible when you select **By motor ratings** for the **Model parameterization** parameter.

RMS starting (or locked rotor) line current

The current that flows when the motor starts, or when the rotor is locked so that it cannot turn. The default value is 7.5 A. This parameter is only visible when you select **By motor ratings** for the **Model parameterization** parameter and **From starting current** for the **L1+L2 parameterization** parameter.

Maximum torque

The maximum value of torque on the torque-slip curve. The default value is 3.3 N*m. This parameter is only visible when you select **By motor ratings** for the **Model parameterization** parameter and **From maximum torque** for the **L1+L2 parameterization** parameter.

R1 parameterization

Select one of the following parameterizations for the equivalent circuit resistance, R_1 , of the motor:

- **From motor efficiency** — Calculate R_1 from the motor efficiency. This is the default method.
- **From power factor** — Calculate R_1 from the motor power factor.
- **Use measured stator resistance R1** — Measure R_1 directly. This parameter is only visible when you select **By motor ratings** for the **Model parameterization** parameter.

Motor efficiency (percent)

the percentage of input power to the motor that gets delivered to the mechanical load when running at the **Rated speed** value. The default value is 95. This parameter is only visible when you select **By motor ratings** for the **Model parameterization** parameter and **From motor efficiency** for the **R1 parameterization** parameter.

Motor power factor

The cosine of the angle by which the supply current lags the supply voltage when running at the **Rated mechanical power** value. The default value is 0.93. This parameter is only visible when you select **By motor ratings** for the **Model parameterization** parameter and **From power factor** for the **R1 parameterization** parameter.

Measured stator resistance R1

the measured stator resistance. The default value is 1 Ω . This parameter is only visible when you select **By motor ratings** for the **Model parameterization** parameter and **Use measured stator resistance R1** for the **R1 parameterization** parameter.

Number of pole pairs

Total number of pole pairs for the motor. The default value is 1.

Number of phases

Number of supply phases. The default value is 3.

Stator connections

Select one of the following motor configurations:

- **Delta configuration** — Connect the motor stator windings in delta configuration. This is the default method.
- **Star configuration** — Connect the motor stator windings in star configuration.

Induction Motor

Power Supply Tab

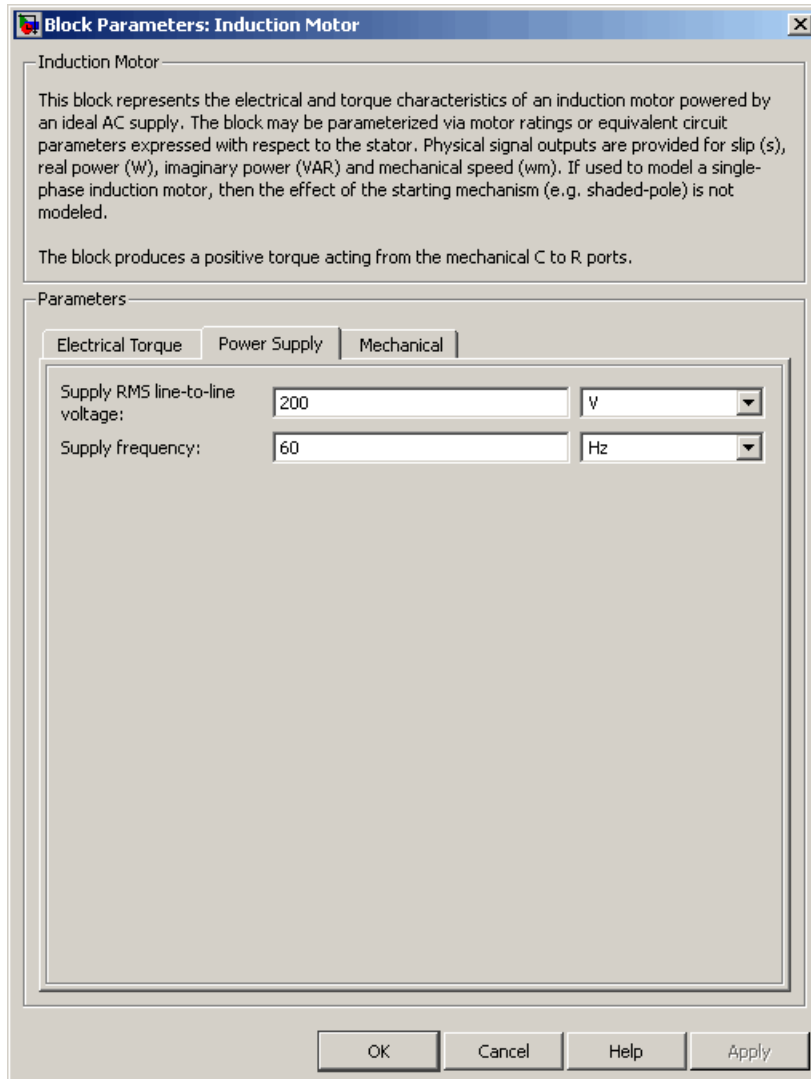

Supply RMS line-to-line voltage

The line-to-line voltage that supplies the motor. The default value is 200 V.

Supply frequency

Frequency of the AC supply voltage. The default value is 60 hertz.

Induction Motor

Mechanical Tab

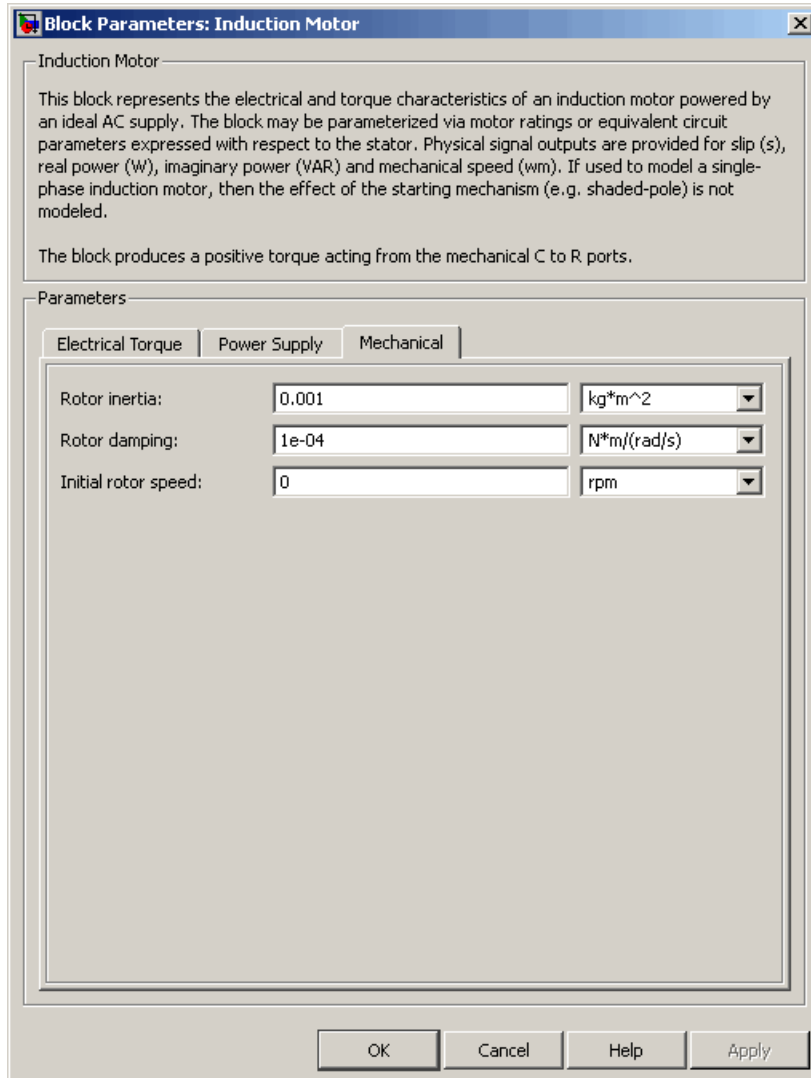

Rotor inertia

Rotor inertia. The default value is $0.1 \text{ kg}\cdot\text{m}^2$. The value can be zero.

Rotor damping

Rotor damping. The default value is $2\text{e-}06 \text{ N}\cdot\text{m}/(\text{rad/s})$. The value can be zero.

Initial rotor speed

Speed of the rotor at the start of the simulation. The default value is 0 rpm.

Ports

The block has the following ports:

W

Real power.

wm

Mechanical speed.

VAR

Imaginary power.

s

Motor slip.

C

Mechanical rotational conserving port.

R

Mechanical rotational conserving port.

References

[1] S.E. Lyshevski. *Electromechanical Systems, Electric Machines, and Applied Mechatronics*, CRC, 1999.

See Also

DC Motor, Servomotor, Shunt Motor, and Universal Motor.

Light-Emitting Diode

Purpose Model light-emitting diode as exponential diode and current sensor in series

Library Sensors

Description



Light-Emitting Diode

The Light-Emitting Diode block represents a light-emitting diode as an exponential diode in series with a current sensor. The optical power presented at the signal port **W** is equal to the product of the current flowing through the diode and the **Optical power per unit current** parameter value.

The exponential diode model provides the following relationship between the diode current I and the diode voltage V :

$$I = IS \times \left(e^{\frac{qV}{NkT}} - 1 \right) \quad V > -V_z$$
$$I = -IS \times \left(e^{\frac{-q(V+V_z)}{kT}} - e^{\frac{qV}{NkT}} \right) \quad V \leq -V_z$$

where:

- q is the elementary charge on an electron (1.602176×10^{-19} Coulombs).
- k is the Boltzmann constant ($1.3806503 \times 10^{-23}$ J/K).
- V_z is the **Reverse breakdown voltage BV** parameter value.
- N is the emission coefficient.
- IS is the saturation current.
- T is the temperature at which the diode parameters are specified, as defined by the **Measurement temperature** parameter value.

When $\frac{qV}{NkT} > 80$, the block replaces $e^{\frac{qV}{NkT}}$ with $\left(\frac{qV}{NkT} - 79 \right) e^{80}$, which matches the gradient of the diode current at $qV/(NkT) = 80$ and

extrapolates linearly. When $\frac{qV}{NkT} < -79$, the block replaces $e^{\frac{qV}{NkT}}$ with $\left(\frac{qV}{NkT} + 80\right)e^{-79}$, which also matches the gradient and extrapolates linearly. Typical electrical circuits do not reach these extreme values. The block provides this linear extrapolation to help convergence when solving for the constraints during simulation.

When you select Use parameters **IS** and **N** for the **Parameterization** parameter, you specify the diode in terms of the **Saturation current IS** and **Emission coefficient N** parameters. When you select Use **I-V curve data points** for the **Parameterization** parameter, you specify two voltage and current measurement points on the diode I-V curve and the block derives the **IS** and **N** values. When you specify current and voltage measurements, the block calculates **IS** and **N** as follows:

- $N = ((V_1 - V_2) / V_t) / (\log(I_1) - \log(I_2))$
- $IS = (I_1 / (\exp(V_1 / (NV_t)) - 1) + I_2 / (\exp(V_2 / (NV_t)) - 1)) / 2$

where:

- $V_t = kT / q$
- V_1 and V_2 are the values in the **Voltages [V1 V2]** vector.
- I_1 and I_2 are the values in the **Currents [I1 I2]** vector.

The exponential diode model provides the option to include a junction capacitance:

- When you select **Fixed** or **zero junction capacitance** for the **Junction capacitance** parameter, the capacitance is fixed.
- When you select Use parameters **CJO**, **VJ**, **M** & **FC** for the **Junction capacitance** parameter, the block uses the coefficients

Light-Emitting Diode

CJO , VJ , M , and FC to calculate a junction capacitance that depends on the junction voltage.

- When you select Use C-V curve data points for the **Junction capacitance** parameter, the block uses three capacitance values on the C-V capacitance curve to estimate CJO , VJ , and M and uses these values with the specified value of FC to calculate a junction capacitance that depends on the junction voltage. The block calculates CJO , VJ , and M as follows:

- $CJO = C_1((V_{R2} - V_{R1}) / (V_{R2} - V_{R1}(C_2 / C_1)^{-1/M}))^M$

- $VJ = -(-V_{R2}(C_1 / C_2)^{-1/M} + V_{R1}) / (1 - (C_1 / C_2)^{-1/M})$

- $M = \log(C_3 / C_2) / \log(V_{R2} / V_{R3})$

where:

- V_{R1} , V_{R2} , and V_{R3} are the values in the **Reverse bias voltages [VR1 VR2 VR3]** vector.

- C_1 , C_2 , and C_3 are the values in the **Corresponding capacitances [C1 C2 C3]** vector.

It is not possible to estimate FC reliably from tabulated data, so you must specify its value using the **Capacitance coefficient FC** parameter. In the absence of suitable data for this parameter, use a typical value of 0.5.

The reverse bias voltages (defined as positive values) should satisfy $V_{R3} > V_{R2} > V_{R1}$. This means that the capacitances should satisfy $C_1 > C_2 > C_3$ as reverse bias widens the depletion region and hence reduces capacitance. Violating these inequalities results in an error. Voltages V_{R2} and V_{R3} should be well away from the Junction potential VJ . Voltage V_{R1} should be less than the Junction potential VJ , with a typical value for V_{R1} being 0.1 V.

The voltage-dependent junction capacitance is defined in terms of the capacitor charge storage Q_j as:

- For $V < FC \times VJ$:

$$Q_j = CJO \times (VJ / (M - 1)) \times ((1 - V / VJ)^{1-M} - 1)$$

- For $V \geq FC \times VJ$:

$$Q_j = CJO \times F_1 + (CJO / F_2) \times (F_3 \times (V - FC \times VJ) + 0.5 * (M / VJ) * (V^2 - (FC \times VJ)^2))$$

where:

- $F_1 = (VJ / (1 - M)) \times (1 - (1 - FC)^{1-M})$
- $F_2 = (1 - FC)^{1+M}$
- $F_3 = 1 - FC \times (1 + M)$

These equations are the same as used in [2], except that the temperature dependence of VJ and FC is not modeled. This model does not include the diffusion capacitance term that affects performance for high frequency switching applications.

Basic Assumptions and Limitations

The Light-Emitting Diode block has the following limitations:

- When you select Use I-V curve data points for the **Parameterization** parameter, choose a pair of voltages near the diode turn-on voltage. Typically this is in the range from 0.05 to 1 Volt. Using values outside of this region may lead to numerical issues and poor estimates for IS and N .
- This block does not model temperature-dependent effects. SimElectronics simulates the block at the temperature at which the component behavior was measured, as specified by the **Measurement temperature** parameter value.

Light-Emitting Diode

- You may need to use nonzero ohmic resistance and junction capacitance values to prevent numerical simulation issues, but the simulation may run faster with these values set to zero.

Dialog Box and Parameters

Main Tab

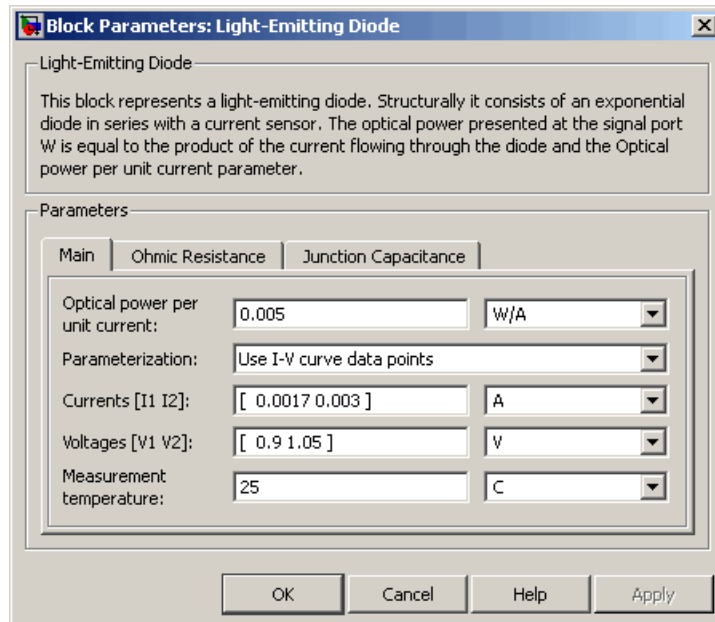

Optical power per unit current

The amount of optical power the light-emitting diode generates per unit of current flowing through the diode. The default value is 0.005 W/A.

Parameterization

Select one of the following methods for model parameterization:

- Use I-V curve data points — Specify measured data at two points on the diode I-V curve. This is the default method.

- Use parameters **IS** and **N** — Specify saturation current and emission coefficient.

Currents [I1 I2]

A vector of the current values at the two points on the diode I-V curve that the block uses to calculate *IS* and *N*. This parameter is only visible when you select **Use I-V curve data points** for the **Parameterization** parameter. The default value is [0.0017 0.003] A.

Voltages [V1 V2]

A vector of the voltage values at the two points on the diode I-V curve that the block uses to calculate *IS* and *N*. This parameter is only visible when you select **Use I-V curve data points** for the **Parameterization** parameter. The default value is [0.9 1.05] V.

Saturation current IS

The magnitude of the current that the ideal diode equation approaches asymptotically for very large reverse bias levels. This parameter is only visible when you select **Use parameters IS and N** for the **Parameterization** parameter. The default value is 5e-05 A.

Measurement temperature

The temperature at which *IS* or the I-V curve was measured. The default value is 25 °C.

Emission coefficient N

The diode emission coefficient or ideality factor. This parameter is only visible when you select **Use parameters IS and N** for the **Parameterization** parameter. The default value is 10.

Light-Emitting Diode

Ohmic Resistance Tab

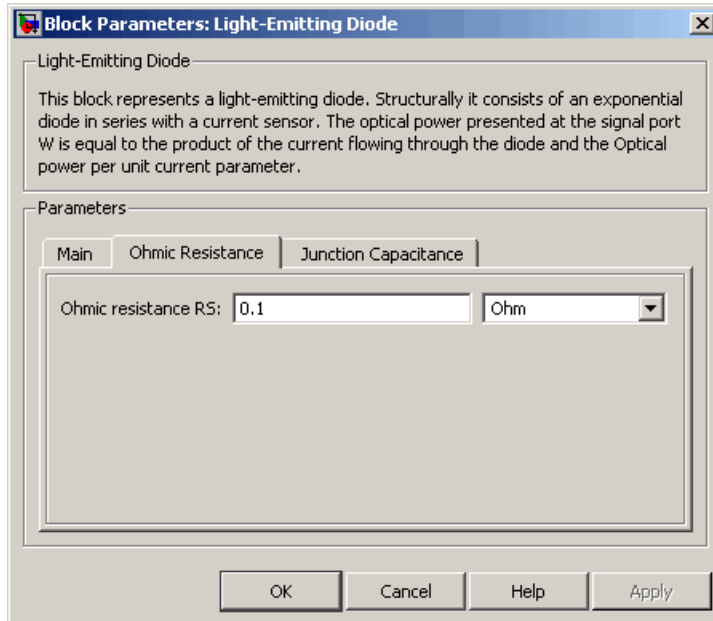

Ohmic resistance RS

The series diode connection resistance. The default value is 0.1 Ω .

Junction Capacitance Tab

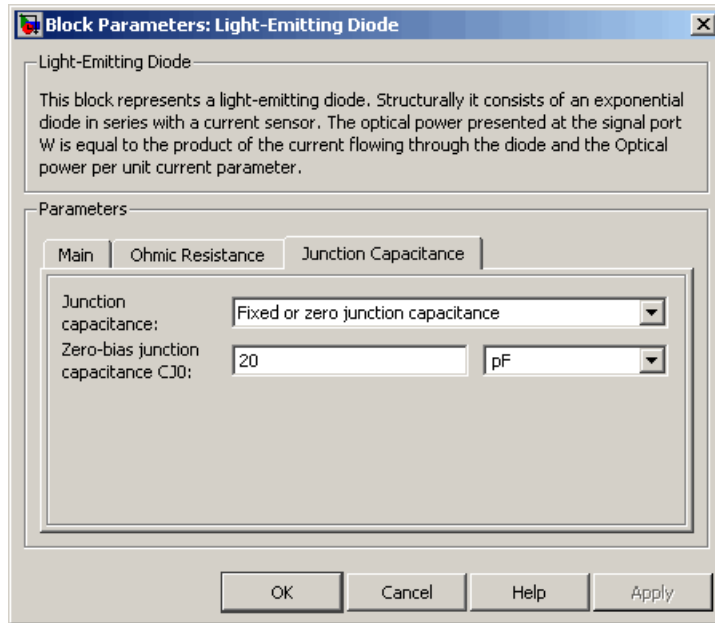

Junction capacitance

Select one of the following options for modeling the junction capacitance:

- **Fixed or zero junction capacitance** — Model the junction capacitance as a fixed value.
- **Use C-V curve data points** — Specify measured data at three points on the diode C-V curve.
- **Use parameters CJO, VJ, M & FC** — Specify zero-bias junction capacitance, junction potential, grading coefficient, and forward-bias depletion capacitance coefficient.

Light-Emitting Diode

Zero-bias junction capacitance **CJ0**

The value of the capacitance placed in parallel with the exponential diode term. This parameter is only visible when you select Fixed or zero junction capacitance or Use parameters **CJ0**, **VJ**, **M** & **FC** for the **Junction capacitance** parameter. The default value is 20 pF.

Reverse bias voltages [**VR1 VR2 VR3**]

A vector of the reverse bias voltage values at the three points on the diode C-V curve that the block uses to calculate **CJ0**, **VJ**, and **M**. This parameter is only visible when you select Use C-V curve data points for the **Junction capacitance** parameter. The default value is [0.1 10 100] V.

Corresponding capacitances [**C1 C2 C3**]

A vector of the capacitance values at the three points on the diode C-V curve that the block uses to calculate **CJ0**, **VJ**, and **M**. This parameter is only visible when you select Use C-V curve data points for the **Junction capacitance** parameter. The default value is [15 10 2] pF.

Junction potential **VJ**

The junction potential. This parameter is only visible when you select Use parameters **CJ0**, **VJ**, **M** & **FC** for the **Junction capacitance** parameter. The default value is 1 V.

Grading coefficient **M**

The grading coefficient. This parameter is only visible when you select Use parameters **CJ0**, **VJ**, **M** & **FC** for the **Junction capacitance** parameter. The default value is 0.5.

Capacitance coefficient **FC**

Fitting coefficient that quantifies the decrease of the depletion capacitance with applied voltage. This parameter is only visible when you select Use C-V curve data points or Use parameters **CJ0**, **VJ**, **M** & **FC** for the **Junction capacitance** parameter. The default value is 0.5.

Ports

The block has the following ports:

W

Optical output power.

+

Electrical conserving port associated with the diode positive terminal.

-

Electrical conserving port associated with the diode negative terminal.

References

- [1] H. Ahmed and P.J. Spreadbury. *Analogue and digital electronics for engineers*. 2nd Edition, Cambridge University Press, 1984.
- [2] G. Massobrio and P. Antognetti. *Semiconductor Device Modeling with SPICE*. 2nd Edition, McGraw-Hill, 1993.

See Also

Diode, Optocoupler, Photodiode

N-Channel IGBT

Purpose Model N-Channel IGBT

Library Semiconductor Devices

Description



N-Channel IGBT

The N-Channel IGBT block models a PNP Bipolar transistor driven by an N-Channel MOSFET, as shown in the following figure:

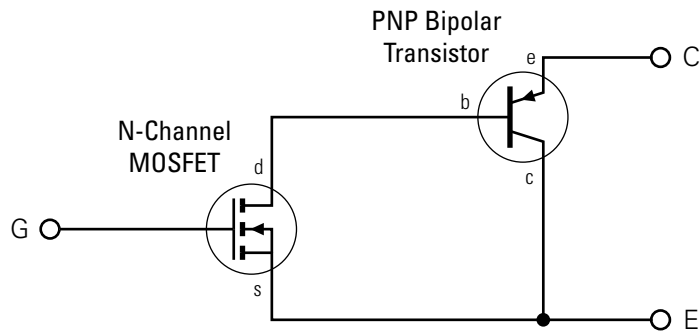

The MOSFET source is connected to the bipolar transistor collector, and the MOSFET drain is connected to the bipolar transistor base. The MOSFET uses the equations shown in the N-Channel MOSFET block reference page. The bipolar transistor uses the equations shown in the PNP Bipolar Transistor block reference page, but with the addition of an emission coefficient parameter N that scales kT/q .

The N-Channel IGBT block uses the on and off characteristics you specify in the block dialog box to estimate the parameter values for the underlying N-Channel MOSFET and PNP bipolar transistor.

- The block uses the off characteristics to calculate the base-emitter voltage, V_{be} , and the saturation current, I_S
 - 1 When the transistor is off, the gate-emitter voltage is zero and the IGBT base-collector voltage is large, so the PNP base and collector current equations simplify to:

$$I_b = 0 = I_s \left[\frac{1}{\beta_F} (e^{-qV_{be}/(NkT)} - 1) - \frac{1}{\beta_R} \right]$$

$$I_c = I_s \left[e^{-qV_{be}/(NkT)} + 1/\beta_R \right]$$

where N is the **Emission coefficient** N parameter value, I_c is the **Zero gate voltage collector current** I_{cs} parameter value, and I_c and I_b are defined as positive flowing out of the collector and base respectively. See the PNP Bipolar Transistor reference page for definitions of the remaining variables.

- 2 The block sets β_R and β_F to typical values of 1 and 50, so these two equations can be used to solve for V_{be} and I_s :

$$V_{be} = \frac{-NkT}{q} \log \left(1 + \frac{\beta_F}{\beta_R} \right)$$

$$I_s = \frac{I_c}{e^{-qV_{be}/(NkT)} + \frac{1}{\beta_R}}$$

Note The block doesn't require an exact value for β_F because it can adjust the MOSFET gain K to ensure the overall device gain is correct.

- The block uses the on characteristics to calculate the MOSFET gain, K .
- 1 The block approximates the base saturation current as

$$I_{b(sat)} = \frac{I_{ce(sat)}}{\beta_F + 1}$$

where $I_{ce(sat)}$ is the **Collector-emitter saturation current Ice(sat)** parameter value.

- 2** When saturated, PNP transistor base current equation simplifies to:

$$I_b = I_s \left[\frac{1}{\beta_F} \left(e^{-qV_{be}/(NkT)} - 1 \right) - \frac{1}{\beta_R} \right]$$

The block substitutes $I_{b(sat)}$ for I_b and solves this equation for $V_{be(sat)}$:

$$V_{be(sat)} = \frac{-NkT}{q} \log \left(\beta_F \left(\frac{I_{b(sat)}}{I_s} + \frac{1}{\beta_R} \right) + 1 \right)$$

- 3** When saturated, the MOSFET equation is:

$$I_{ds} = I_b = K \left[(V_{GE(sat)} - V_{th})V_{ds} - \frac{V_{ds}^2}{2} \right]$$

where V_{th} is the **Gate-emitter threshold voltage Vge(th)** parameter value and $V_{GE(sat)}$ is the **Gate-emitter voltage for {Vce(sat),Ice(sat)}** parameter value.

V_{ds} is related to the transistor voltages as $V_{ds} = V_{CE} - V_{be}$. The block substitutes this relationship for V_{ds} , sets the base-emitter voltage and base current to their saturated values, and rearranges the MOSFET equation to give

$$K = \frac{I_{b(sat)}}{\left[(V_{GE(sat)} - V_{th})(V_{be(sat)} + V_{CE(sat)}) - \frac{(V_{be(sat)} + V_{CE(sat)})^2}{2} \right]}$$

where $V_{CE(sat)}$ is the **Collector-emitter saturation voltage Vce(sat)** parameter value.

These calculations ensure the zero gate voltage collector current and collector-emitter saturation voltage are exactly met at these two specified conditions. However, the current-voltage plots are very sensitive to the emission coefficient N and the precise value of V_{th} . If the manufacturer datasheet gives current-voltage plots for different V_{GE} values, then the N and V_{th} can be tuned by hand to improve the match.

The block models gate junction capacitance as a fixed gate-emitter capacitance C_{GE} and a fixed gate-collector capacitance C_{GC} . If you select **Specify** using equation parameters directly for the **Parameterization** parameter, you specify these values directly using the **Gate-emitter junction capacitance** and **Gate-collector junction capacitance** parameters. Otherwise, the block derives them from the **Input capacitance Cies** and **Reverse transfer capacitance Cres** parameter values that IGBT datasheets usually provide. The two parameterizations are related as follows:

- $C_{GE} = Cres$
- $C_{GC} = Cies - Cres$

Basic Assumptions and Limitations

The model is based on the following assumptions:

- This block does not allow you to specify initial conditions on the junction capacitances. If you select the **Start simulation from steady state** option in the Solver Configuration block, the block solves the initial voltages to be consistent with the calculated steady state. Otherwise, voltages are zero at the start of the simulation.
- This block does not model temperature-dependent effects. SimElectronics simulates the block at the temperature at which the component behavior was measured, as specified by the **Measurement temperature** parameter value.
- You may need to use nonzero junction capacitance values to prevent numerical simulation issues, but the simulation may run faster with these values set to zero.

N-Channel IGBT

Dialog Box and Parameters

Main Tab

Block Parameters: N-Channel IGBT

N-Channel IGBT

This block represents an N-channel IGBT. The underlying model is based on a PNP bipolar transistor plus an N-channel MOSFET whose parameters are derived from the IGBT datasheet parameters. It is assumed that both the MOSFET gate resistance and the bipolar forward Early voltage are infinite. There is no integral reverse diode, and reverse breakdown is not modeled.

Parameters

Main | Junction Capacitance

Zero gate voltage collector current Ices: 2 mA

Gate-emitter threshold voltage Vge(th): 6 V

Collector-emitter saturation voltage Vce(sat): 2.8 V

Collector-emitter saturation current Ice(sat): 400 A

Gate-emitter voltage for {Vce(sat),Ice(sat)}: 15 V

Emission coefficient N: 1

Measurement temperature: 25 C

OK Cancel Help Apply

Zero gate voltage collector current Ices

The collector current that flows when the gate-emitter voltage is set to zero, and a large collector-emitter voltage is applied i.e. the device is in the off-state. The default value is 2 mA.

Gate-emitter threshold voltage Vge(th)

The threshold voltage used in the MOSFET equations. The default value is 6 V.

Collector-emitter saturation voltage $V_{ce(sat)}$

The collector-emitter voltage for a typical on-state as specified by the manufacturer. The default value is 2.8 V.

Collector-emitter saturation current $I_{ce(sat)}$

The collector-emitter current when the gate-emitter voltage is $V_{ge(sat)}$ and collector-emitter voltage is $V_{ce(sat)}$. The default value is 400 A.

Gate-emitter voltage for $\{V_{ce(sat)}, I_{ce(sat)}\}$

The gate voltage used when measuring $V_{ce(sat)}$ and $I_{ce(sat)}$. The default value is 15 V.

Emission coefficient N

The emission coefficient or ideality factor of the bipolar transistor. The default value is 1.

Measurement temperature

The temperature for which the parameters are quoted. It is also the temperature at which the device is simulated. The default value is 25 C.

Junction Capacitance Tab

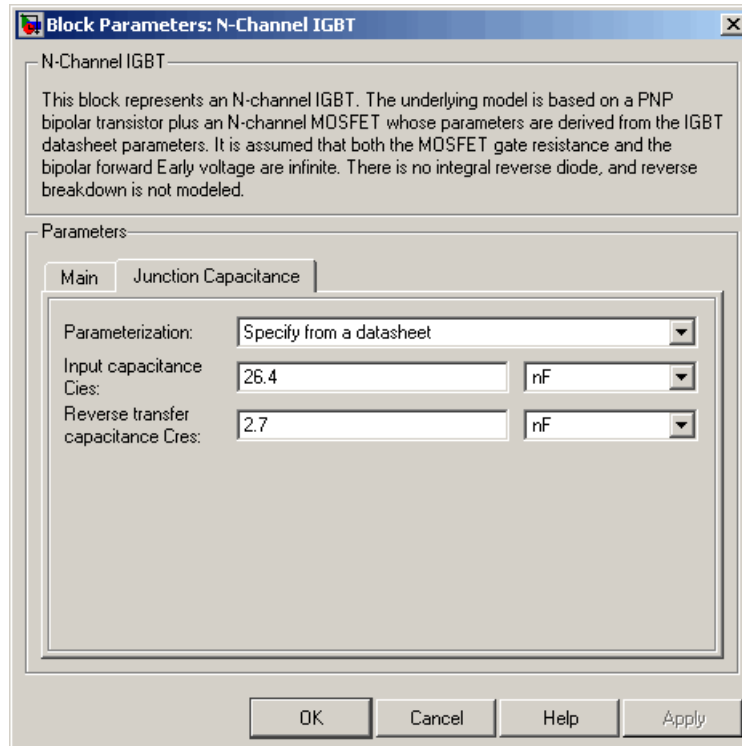

Parameterization

Select one of the following methods for block parameterization:

- **Specify from a datasheet** — Provide parameters that the block converts to junction capacitance values. This is the default method.
- **Specify using equation parameters directly** — Provide junction capacitance parameters directly.

Input capacitance C_{ies}

The gate-emitter capacitance with the collector shorted to the source. This parameter is only visible when you select **Specify** from a datasheet for the **Model junction capacitance** parameter. The default value is 26.4 nF.

Reverse transfer capacitance C_{res}

The collector-gate capacitance with the emitter connected to ground. This parameter is only visible when you select **Specify** from a datasheet for the **Model junction capacitance** parameter. The default value is 2.7 nF.

Gate-emitter junction capacitance

The value of the capacitance placed between the gate and the emitter. This parameter is only visible when you select **Specify** using equation parameters directly for the **Model junction capacitance** parameter. The default value is 23.7 nF.

Gate-collector junction capacitance

The value of the capacitance placed between the gate and the collector. This parameter is only visible when you select **Specify** using equation parameters directly for the **Model junction capacitance** parameter. The default value is 2.7 nF.

Ports

The block has the following ports:

C

Electrical conserving port associated with the PNP emitter terminal.

G

Electrical conserving port associated with the MOSFET gate terminal.

E

Electrical conserving port associated with the PNP collector terminal.

N-Channel JFET

Purpose Model N-Channel JFET

Library Semiconductor Devices

Description The N-Channel JFET block uses the Shichman and Hodges equations to represent an N-Channel JFET using a model with the following structure:



N-Channel JFET

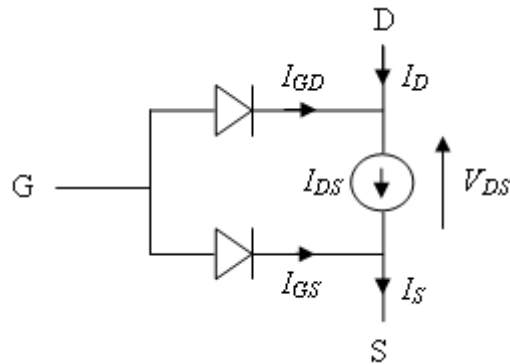

G is the transistor gate, D is the transistor drain and S is the transistor source. The drain-source current, I_{ds} , depends on the region of operation and whether the transistor is operating in normal or inverse mode.

- In normal mode ($V_{ds} \geq 0$), the block provides the following relationship between the drain-source current I_{ds} and the drain-source voltage V_{ds} .

Region	Applicable Range of V_{gs} and V_{ds} Values	Corresponding I_{ds} Equation
Off	$V_{gs} - V_{to} \leq 0$	$I_{ds} = 0$

Region	Applicable Range of V_{gs} and V_{ds} Values	Corresponding I_{ds} Equation
Linear	$0 < V_{ds} < V_{gs} - V_{to}$	$I_{ds} = \beta V_{ds} \left(2(V_{gs} - V_{to}) - V_{ds} \right) (1 + \lambda V_{ds})$
Saturated	$0 < V_{gs} - V_{to} \leq V_{ds}$	$I_{ds} = \beta (V_{gs} - V_{to})^2 (1 + \lambda V_{ds})$

- In inverse mode ($V_{ds} < 0$), the block provides the following relationship between the drain-source current I_{ds} and the drain-source voltage V_{ds} .

Region	Applicable Range of V_{gs} and V_{ds} Values	Corresponding I_{ds} Equation
Off	$V_{gd} - V_{to} \leq 0$	$I_{ds} = 0$
Linear	$0 < -V_{ds} < V_{gs} - V_{to}$	$I_{ds} = \beta V_{ds} \left(2(V_{gd} - V_{to}) + V_{ds} \right) (1 - \lambda V_{ds})$
Saturated	$0 < V_{gd} - V_{to} \leq -V_{ds}$	$I_{ds} = -\beta (V_{gd} - V_{to})^2 (1 - \lambda V_{ds})$

In the preceding equations:

- V_{gs} is the gate-source voltage.
- V_{gd} is the gate-drain voltage.

N-Channel JFET

- V_{to} is the threshold voltage. If you select **Specify using equation parameters directly** for the **Parameterization** parameter, V_{to} is the **Threshold voltage** parameter value. Otherwise, the block calculates V_{to} from the datasheet parameters you specify.
- β is the transconductance parameter. If you select **Specify using equation parameters directly** for the **Parameterization** parameter, β is the **Transconductance parameter** parameter value. Otherwise, the block calculates β from the datasheet parameters you specify.
- λ is the channel-length modulation parameter. If you select **Specify using equation parameters directly** for the **Parameterization** parameter, λ is the **Channel-length modulation** parameter value. Otherwise, the block calculates λ from the datasheet parameters you specify.

The currents in each of the diodes satisfy the exponential diode equation

$$I_{gd} = I_S \times \left(e^{\frac{qV_{gd}}{kT}} - 1 \right)$$
$$I_{gs} = I_S \times \left(e^{\frac{qV_{gs}}{kT}} - 1 \right)$$

Where:

- I_S is the saturation current. If you select **Specify using equation parameters directly** for the **Parameterization** parameter, I_S is the **Saturation current** parameter value. Otherwise, the block calculates I_S from the datasheet parameters you specify.
- q is the elementary charge on an electron.
- k is the Boltzmann constant.
- T is the diode temperature. The value comes from the **Measurement temperature** parameter.

The block models gate junction capacitance as a fixed gate-drain capacitance C_{GD} and a fixed gate-source capacitance C_{GS} . If you select **Specify** using equation parameters directly for the **Parameterization** parameter, you specify these values directly using the **Gate-drain junction capacitance** and **Gate-source junction capacitance** parameters. Otherwise, the block derives them from the **Input capacitance** C_{iss} and **Reverse transfer capacitance** C_{rss} parameter values. The two parameterizations are related as follows:

- $C_{GD} = C_{rss}$
- $C_{GS} = C_{iss} - C_{rss}$

Basic Assumptions and Limitations

The model is based on the following assumptions:

- This block does not allow you to specify initial conditions on the junction capacitances. If you select the **Start simulation from steady state** option in the Solver Configuration block, the block solves the initial voltages to be consistent with the calculated steady state. Otherwise, voltages are zero at the start of the simulation.
- This block does not model temperature-dependent effects. SimElectronics simulates the block at the temperature at which the component behavior was measured, as specified by the **Measurement temperature** parameter value.
- You may need to use nonzero ohmic resistance and junction capacitance values to prevent numerical simulation issues, but the simulation may run faster with these values set to zero.

N-Channel JFET

Dialog Box and Parameters

Main Tab

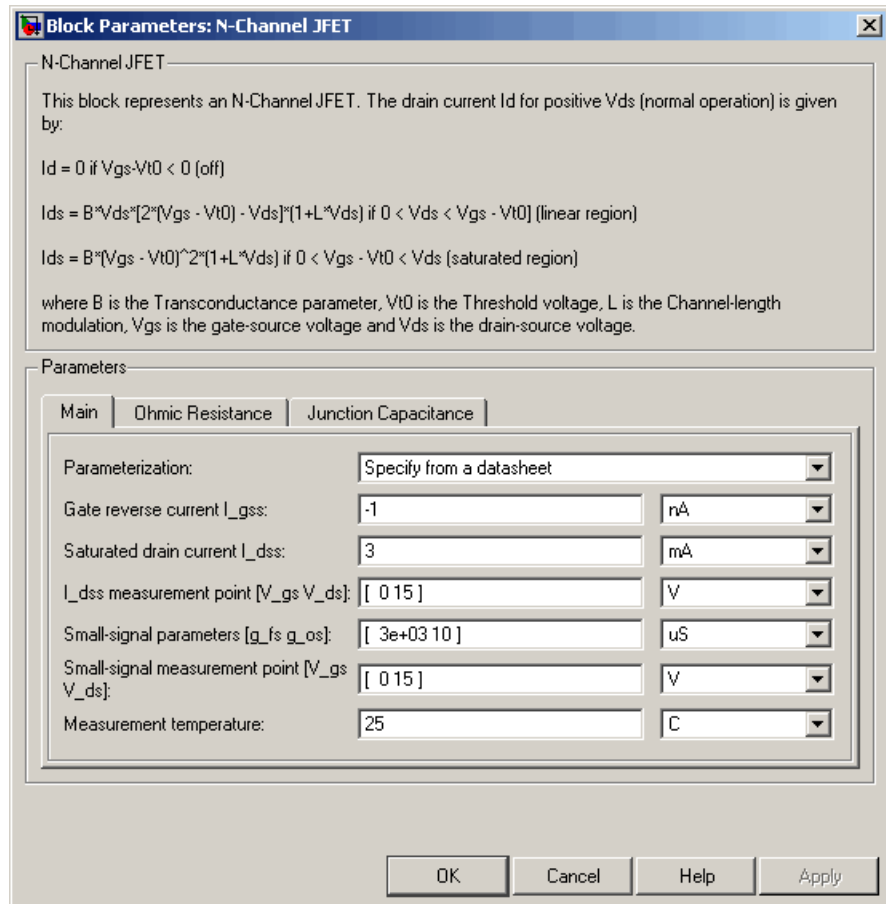

Parameterization

Select one of the following methods for block parameterization:

- Specify from a datasheet — Provide parameters that the block converts to equations that describe the transistor. This is the default method.

- Specify using equation parameters directly — Provide equation parameters V_{to} , β , λ , and I_S .

Gate reverse current I_{gss}

The reverse current that flows in the diode when the drain and source are short-circuited and a large negative gate-source voltage is applied. This parameter is only visible when you select **Specify** from a datasheet for the **Parameterization** parameter. The default value is -1 nA.

Saturated drain current I_{dss}

The current that flows when a large positive drain-source voltage is applied for a specified gate-source voltage. For a depletion-mode device, this gate-source voltage may be zero, in which case I_{dss} may be referred to as the zero-gate voltage drain current. This parameter is only visible when you select **Specify** from a datasheet for the **Parameterization** parameter. The default value is 3 mA.

I_{dss} measurement point [V_{gs} V_{ds}]

A vector of the values of V_{gs} and V_{ds} at which I_{dss} is measured. Normally V_{gs} is zero. V_{ds} should be greater than zero. This parameter is only visible when you select **Specify** from a datasheet for the **Parameterization** parameter. The default value is [0 15] V.

Small-signal parameters [g_{fs} g_{os}]

A vector of the values of g_{fs} and g_{os} . g_{fs} is the forward transfer conductance, i.e. the conductance for a fixed drain-source voltage. g_{os} is the output conductance, i.e. the conductance for a fixed gate-source voltage. This parameter is only visible when you select **Specify** from a datasheet for the **Parameterization** parameter. The default value is [3e+03 10] uS.

Small-signal measurement point [V_{gs} V_{ds}]

A vector of the values of V_{gs} and V_{ds} at which g_{fs} and g_{os} are measured. V_{ds} should be greater than zero. For depletion-mode devices, V_{gs} is typically zero. This parameter is only

N-Channel JFET

visible when you select **Specify** from a datasheet for the **Parameterization** parameter. The default value is [0 15] V.

Transconductance parameter

The derivative of drain current with respect to gate voltage. This parameter is only visible when you select **Specify** using equation parameters directly for the **Parameterization** parameter. The default value is $1e-04$ A/V².

Saturation current

The magnitude of the current that the ideal diode equation approaches asymptotically for very large reverse bias levels. This parameter is only visible when you select **Specify** using equation parameters directly for the **Parameterization** parameter. The default value is $1e-14$ A.

Measurement temperature

The temperature for which the datasheet parameters are quoted. It is also the temperature at which the device is simulated. The default value is 25 C.

Threshold voltage

The gate-source voltage above which the transistor produces a nonzero drain current. For an enhancement device, V_{t0} should be positive. For a depletion mode device, V_{t0} should be negative. This parameter is only visible when you select **Specify** using equation parameters directly for the **Parameterization** parameter. The default value is -2 V.

Channel-length modulation

The channel-length modulation. This parameter is only visible when you select **Specify** using equation parameters directly for the **Parameterization** parameter. The default value is 0 1/V.

Ohmic Resistance Tab

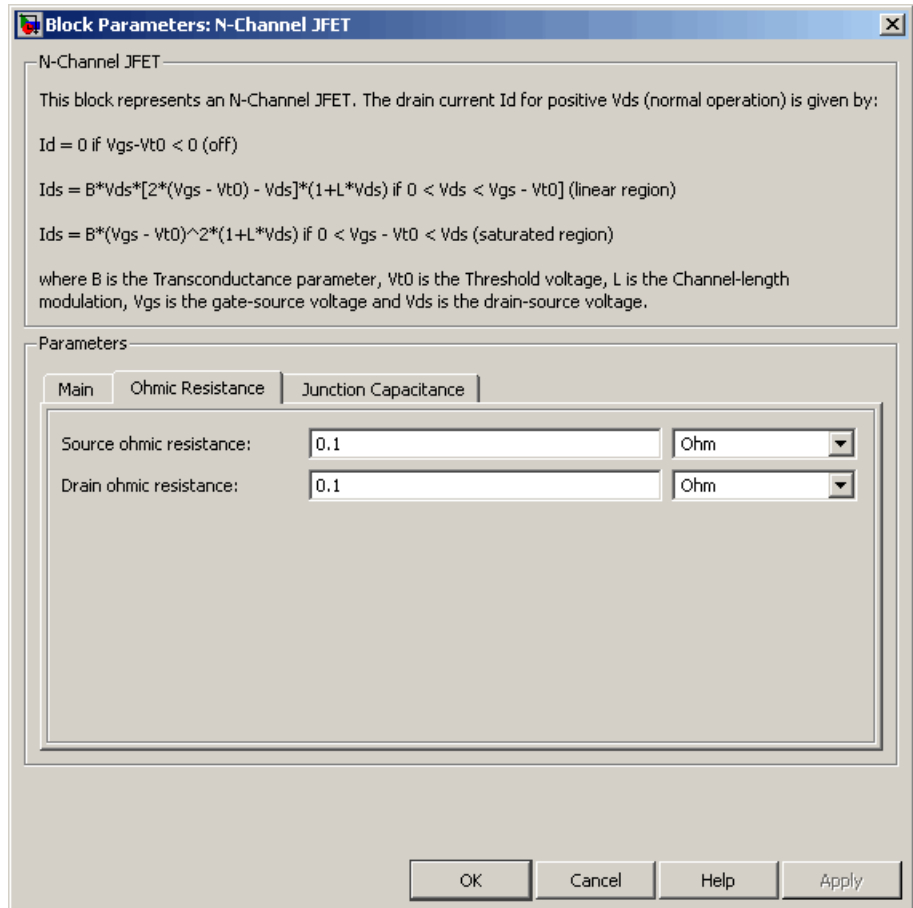

Source ohmic resistance

The transistor source resistance. The default value is 0.1 Ω . The value must be greater than or equal to 0.

N-Channel JFET

Drain ohmic resistance

The transistor drain resistance. The default value is 0.1 Ω . The value must be greater than or equal to 0.

Junction Capacitance Tab

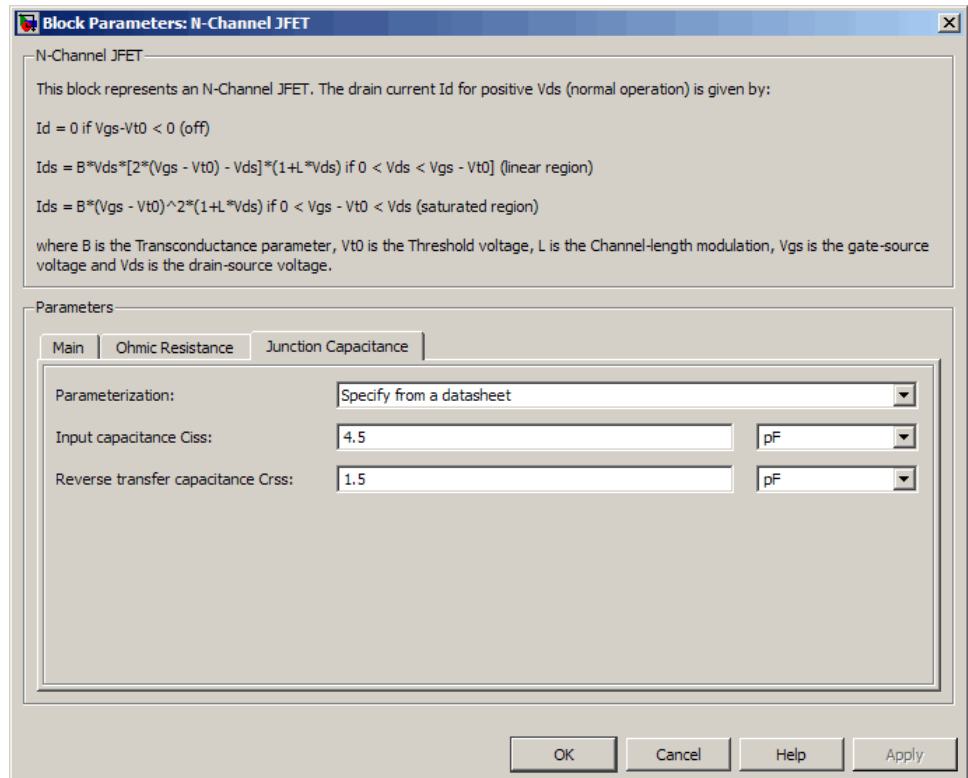

Parameterization

Select one of the following methods for block parameterization:

- Specify from a datasheet — Provide parameters that the block converts to junction capacitance values. This is the default method.

- Specify using equation parameters directly — Provide junction capacitance parameters directly.

Input capacitance C_{iss}

The gate-source capacitance with the drain shorted to the source. This parameter is only visible when you select **Specify** from a datasheet for the **Model junction capacitance** parameter. The default value is 4.5 pF.

Reverse transfer capacitance C_{rss}

The drain-gate capacitance with the source connected to ground. This parameter is only visible when you select **Specify** from a datasheet for the **Model junction capacitance** parameter. The default value is 1.5 pF.

Gate-source junction capacitance

The value of the capacitance placed between the gate and the source. This parameter is only visible when you select **Specify** using equation parameters directly for the **Model junction capacitance** parameter. The default value is 3 pF.

Gate-drain junction capacitance

The value of the capacitance placed between the gate and the drain. This parameter is only visible when you select **Specify** using equation parameters directly for the **Model junction capacitance** parameter. The default value is 1.5 pF.

Ports

The block has the following ports:

G

Electrical conserving port associated with the transistor gate terminal.

D

Electrical conserving port associated with the transistor drain terminal.

S

Electrical conserving port associated with the transistor source terminal.

N-Channel JFET

References

[1] H. Shichman and D. A. Hodges, *Modeling and simulation of insulated-gate field-effect transistor switching circuits*. IEEE J. Solid State Circuits, SC-3, 1968.

[2] G. Massobrio and P. Antognetti. *Semiconductor Device Modeling with SPICE*. 2nd Edition, McGraw-Hill, 1993. Chapter 2.

See Also

P-Channel JFET

Purpose

Model N-Channel MOSFET using Shichman-Hodges equation

Library

Semiconductor Devices

Description



N-Channel MOSFET

The N-Channel MOSFET block uses the Shichman and Hodges equations [1] for an insulated-gate field-effect transistor to represent an N-Channel MOSFET.

The drain-source current, I_{DS} , depends on the region of operation:

- In the off region ($V_{GS} < V_{th}$) the drain-source current is:

$$I_{DS} = 0$$

- In the linear region ($0 < V_{DS} < V_{GS} - V_{th}$) the drain-source current is:

$$I_{DS} = K \left((V_{GS} - V_{th})V_{DS} - V_{DS}^2 / 2 \right)$$

- In the saturated region ($0 < V_{GS} - V_{th} < V_{DS}$) the drain-source current is:

$$I_{DS} = (K / 2)(V_{GS} - V_{th})^2$$

In the preceding equations:

- K is the transistor gain.
- V_{DS} is the positive drain-source voltage.
- V_{GS} is the gate-source voltage.
- V_{th} is the threshold voltage.

The block models gate junction capacitance as a fixed gate-drain capacitance C_{GD} and a fixed gate-source capacitance C_{GS} . If you select **Specify** using equation parameters directly for the

N-Channel MOSFET

Parameterization parameter in the **Junction Capacitance** tab, you specify these values directly using the **Gate-drain junction capacitance** and **Gate-source junction capacitance** parameters. Otherwise, the block derives them from the **Input capacitance** C_{iss} and **Reverse transfer capacitance** C_{rss} parameter values. The two parameterizations are related as follows:

- $C_{GD} = C_{rss}$
- $C_{GS} = C_{iss} - C_{rss}$

Dialog Box and Parameters

Main Tab

Block Parameters: N-Channel MOSFET

N-Channel MOSFET

This block represents an N-channel MOSFET (or IGFET). The drain-source current I_{ds} for positive V_{ds} is given by:

$I_{ds} = 0$ if $V_{gs} < V_{th}$ (off)

$I_{ds} = K * [(V_{gs} - V_{th}) * V_{ds} - V_{ds}^2 / 2]$ if $0 < V_{ds} < V_{gs} - V_{th}$ (linear region)

$I_{ds} = (K/2) * (V_{gs} - V_{th})^2$ if $0 < V_{gs} - V_{th} < V_{ds}$ (saturated region)

where K is a constant, V_{th} is the Threshold voltage, V_{gs} is the gate-source voltage and V_{ds} is the drain-source voltage.

Parameters

Main | Ohmic Resistance | Junction Capacitance

Parameterization: Specify from a datasheet

Drain-source on resistance, $R_{DS(on)}$: 0.025 Ohm

Drain current, I_{ds} , for $R_{DS(on)}$: 6 A

Gate-source voltage, V_{gs} , for $R_{DS(on)}$: 10 V

Gate-source threshold voltage V_{th} : 1.7 V

OK Cancel Help Apply

Parameterization

Select one of the following methods for block parameterization:

- **Specify from a datasheet** — Provide the drain-source on resistance and the corresponding drain current and gate-source voltage. The block calculates the transistor gain for the

N-Channel MOSFET

Shichman and Hodges equations from this information. This is the default method.

- Specify using equation parameters directly — Provide the transistor gain.

Drain-source on resistance, R_DS(on)

The ratio of the drain-source voltage to the drain current for specified values of drain current and gate-source voltage.

$R_{DS(on)}$ should have a positive value. This parameter is only visible when you select **Specify** from a datasheet for the **Parameterization** parameter. The default value is 0.025 Ω .

Drain current, Ids, for R_DS(on)

The drain current the block uses to calculate the value of the drain-source resistance. I_{DS} should have a positive value. This parameter is only visible when you select **Specify** from a datasheet for the **Parameterization** parameter. The default value is 6 A.

Gate-source voltage, Vgs, for R_DS(on)

The gate-source voltage the block uses to calculate the value of the drain-source resistance. V_{GS} should have a positive value. This parameter is only visible when you select **Specify** from a datasheet for the **Parameterization** parameter. The default value is 10 V.

Gain K

Positive constant gain coefficient for the Shichman and Hodges equations. This parameter is only visible when you select **Specify using equation parameters directly** for the **Parameterization** parameter. The default value is 5 A/V².

Gate-source threshold voltage Vth

Gate-source threshold voltage V_{th} in the Shichman and Hodges equations. For an enhancement device, V_{th} should be positive. For a depletion mode device, V_{th} should be negative. The default value is 1.7 V.

Ohmic Resistance Tab

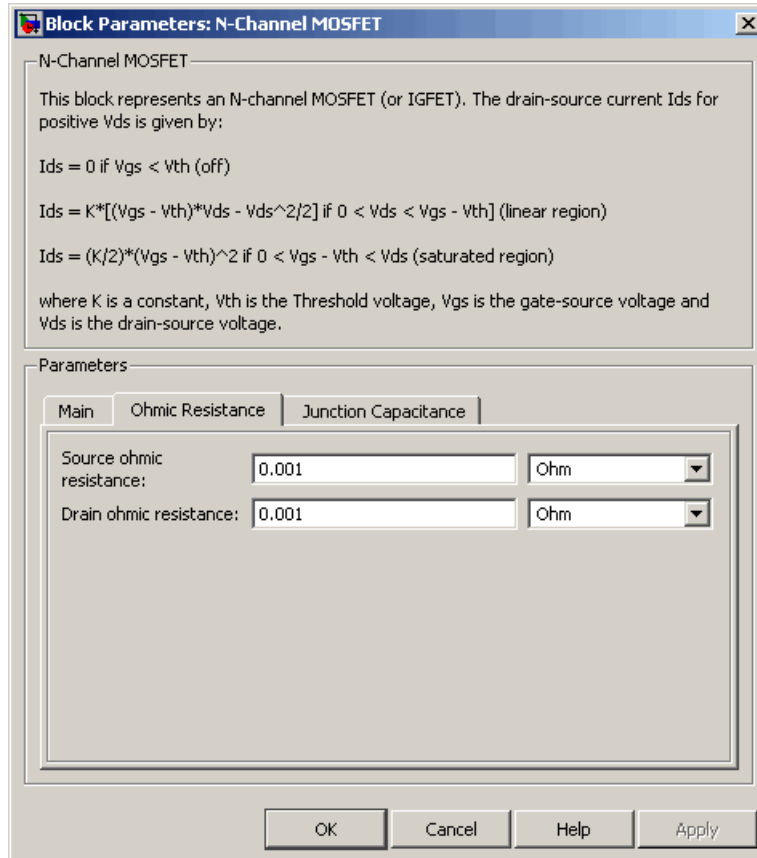

Source ohmic resistance

The transistor source resistance. The default value is 0.001 Ω .
The value must be greater than or equal to 0.

Drain ohmic resistance

The transistor drain resistance. The default value is 0.001 Ω .
The value must be greater than or equal to 0.

N-Channel MOSFET

Junction Capacitance Tab

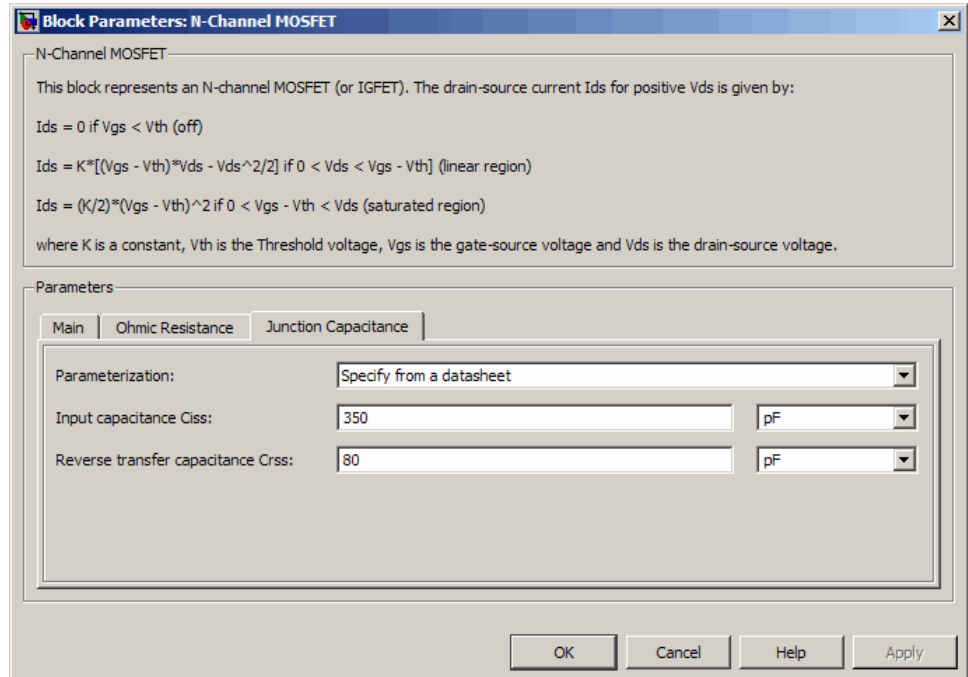

Parameterization

Select one of the following methods for capacitance parameterization:

- **Specify from a datasheet** — Provide parameters that the block converts to junction capacitance values. This is the default method.
- **Specify using equation parameters directly** — Provide junction capacitance parameters directly.

Input capacitance C_{iss}

The gate-source capacitance with the drain shorted to the source. This parameter is only visible when you select **Specify from a**

datasheet for the **Parameterization** parameter. The default value is 350 pF.

Reverse transfer capacitance Crss

The drain-gate capacitance with the source connected to ground. This parameter is only visible when you select **Specify** from a datasheet for the **Parameterization** parameter. The default value is 80 pF.

Gate-source junction capacitance

The value of the capacitance placed between the gate and the source. This parameter is only visible when you select **Specify using equation parameters directly** for the **Parameterization** parameter. The default value is 270 pF.

Gate-drain junction capacitance

The value of the capacitance placed between the gate and the drain. This parameter is only visible when you select **Specify using equation parameters directly** for the **Parameterization** parameter. The default value is 80 pF.

Ports

The block has the following ports:

G

Electrical conserving port associated with the transistor gate terminal.

D

Electrical conserving port associated with the transistor drain terminal.

S

Electrical conserving port associated with the transistor source terminal.

References

[1] H. Shichman and D. A. Hodges. "Modeling and simulation of insulated-gate field-effect transistor switching circuits." IEEE J. Solid State Circuits, SC-3, 1968.

N-Channel MOSFET

See Also

P-Channel MOSFET

Purpose Model ideal negative supply rail

Library Sources

Description



Negative Supply Rail

The Negative Supply Rail block represents an ideal negative supply rail. Use this block instead of the Simscape DC Voltage Source block to define the output voltage relative to the Simscape Electrical Reference block that must appear in each model.

Note Do not attach more than one Negative Supply Rail block to any connected line.

Dialog Box and Parameters

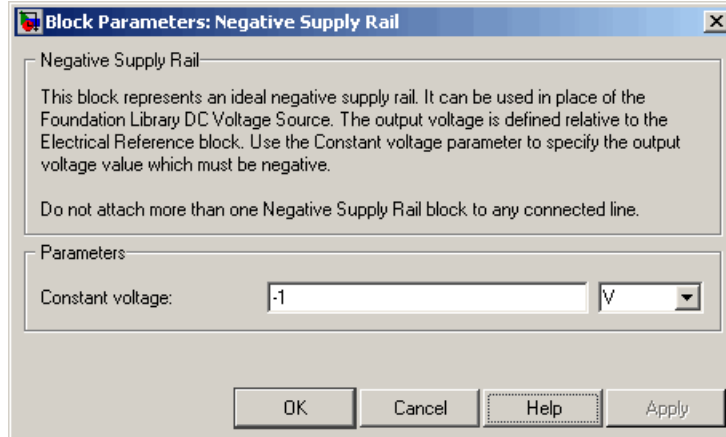

Negative Supply Rail

Constant voltage

The voltage at the output port relative to the Electrical Reference block ground port. The value must be less than zero. The default value is -1 V.

Ports

The block has the following ports:

-

Negative electrical voltage.

See Also

Simscape DC Voltage Source, Positive Supply Rail

Purpose Model SPICE-compatible N-Channel JFET

Library SPICE-Compatible Semiconductors

Description The NJFET block represents a SPICE-compatible N-channel JFET.

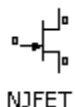

The NJFET block model includes the following components:

- “Gate-Source Current-Voltage Model” on page 2-179
- “Gate-Drain Current-Voltage Model” on page 2-180
- “Drain-Source Current-Voltage Model” on page 2-181
- “Junction Charge Model” on page 2-182
- “Temperature Dependence” on page 2-184

Gate-Source Current-Voltage Model

The block provides the following relationship between the gate-source current I_{gs} and the gate-source voltage V_{gs} after adjusting the applicable model parameters for temperature.

Applicable Range of V_{gs} Values	Corresponding I_{gs} Equation
$V_{gs} > 80 * V_t$	$I_{gs} = IS * \left(\left(\frac{V_{gs}}{V_t} - 79 \right) e^{80} - 1 \right) + V_{gs} * G \text{ min}$
$80 * V_t \geq V_{gs}$	$I_{gs} = IS * \left(e^{V_{gs}/V_t} - 1 \right) + V_{gs} * G \text{ min}$

Where:

- IS is the **Saturation current**, IS parameter value.
- $V_t = ND * k * T/q$
- ND is the **Emission coefficient**, ND parameter value.

- q is the elementary charge on an electron.
- k is the Boltzmann constant.
- T is the diode temperature:
 - If you select `Device` temperature for the **Model temperature dependence using** parameter, T is the sum of the **Circuit temperature** value plus the **Offset local circuit temperature, TOFFSET** parameter value. The **Circuit temperature** value comes from the SPICE Environment Parameters block, if one exists in the circuit. Otherwise, it comes from the default value for this block.
 - If you select `Fixed` temperature for the **Model temperature dependence using** parameter, T is the **Fixed circuit temperature, TFIXED** parameter value.
- $GMIN$ is the diode minimum conductance. By default, $GMIN$ matches the **Minimum conductance GMIN** parameter of the SPICE Environment Parameters block, whose default value is 1e-12. To change $GMIN$, add a SPICE Environment Parameters block to your model and set the **Minimum conductance GMIN** parameter to the desired value.

Gate-Drain Current-Voltage Model

The block provides the following relationship between the gate-drain current I_{gd} and the gate-drain voltage V_{gd} after adjusting the applicable model parameters for temperature.

Applicable Range of V_{gd} Values	Corresponding I_{gd} Equation
$V_{gd} > 80 * V_t$	$I_{gd} = IS * \left(\left(\frac{V_{gd}}{V_t} - 79 \right) e^{80} - 1 \right) + V_{gd} * G \min$
$80 * V_t \geq V_{gd}$	$I_{gd} = IS * \left(e^{V_{gd}/V_t} - 1 \right) + V_{gd} * G \min$

Drain-Source Current-Voltage Model

The block provides the following relationship between the drain-source current I_{ds} and the drain-source voltage V_{ds} in normal mode ($V_{ds} \geq 0$) after adjusting the applicable model parameters for temperature.

Applicable Range of V_{gs} and V_{gd} Values	Corresponding I_{ds} Equation
$V_{gs} - V_{to} \leq 0$	$I_{ds} = 0$
$0 < V_{gs} - V_{to} \leq V_{ds}$	$I_{ds} = \beta (V_{gs} - V_{to})^2 (1 + \lambda V_{ds})$
$0 < V_{ds} < V_{gs} - V_{to}$	$I_{ds} = \beta V_{ds} (2(V_{gs} - V_{to}) - V_{ds}) (1 + \lambda V_{ds})$

Where:

- V_{to} is the **Threshold voltage, VTO** parameter value.
- β is the **Transconductance, BETA** parameter value.
- λ is the **Channel modulation, LAMBDA** parameter value.

The block provides the following relationship between the drain-source current I_{ds} and the drain-source voltage V_{ds} in inverse mode ($V_{ds} < 0$) after adjusting the applicable model parameters for temperature.

Applicable Range of V_{gs} and V_{gd} Values	Corresponding I_{ds} Equation
$V_{gd} - V_{to} \leq 0$	$I_{ds} = 0$

Applicable Range of V_{gs} and V_{gd} Values	Corresponding I_{ds} Equation
$0 < V_{gd} - V_{to} \leq -V_{ds}$	$I_{ds} = -\beta (V_{gd} - V_{to})^2 (1 - \lambda V_{ds})$
$0 < -V_{ds} < V_{gs} - V_{to}$	$I_{ds} = \beta V_{ds} (2(V_{gd} - V_{to}) + V_{ds}) (1 - \lambda V_{ds})$

Junction Charge Model

The block provides the following relationship between the gate-source charge Q_{gs} and the gate-source voltage V_{gs} after adjusting the applicable model parameters for temperature.

Applicable Range of V_{gs} Values	Corresponding Q_{gs} Equation
$V_{gs} < FC * VJ$	$Q_{gs} = \frac{CGS * VJ * \left(1 - \left(1 - \frac{V_{gs}}{VJ} \right)^{1-MG} \right)}{1 - MG}$
$V_{gs} \geq FC * VJ$	$Q_{gs} = CGS * \left(F1 + \frac{F3 * (V_{gs} - FC * VJ) + \frac{MG * (V_{gs}^2 - (FC * VJ)^2)}{2 * VJ}}{F2} \right)$

Where:

- FC is the **Capacitance coefficient FC** parameter value.
- VJ is the **Junction potential VJ** parameter value.

- **CGS** is the **Zero-bias GS capacitance**, **CGS** parameter value.
- **MG** is the **Grading coefficient**, **MG** parameter value.

- $$F1 = \frac{VJ * (1 - (1 - FC)^{1-MG})}{1 - MG}$$
- $$F2 = (1 - FC)^{1+MG}$$
- $$F3 = 1 - FC * (1 + MG)$$

The block provides the following relationship between the gate-drain charge Q_{gd} and the gate-drain voltage V_{gd} after adjusting the applicable model parameters for temperature.

Applicable Range of V_{gd} Values	Corresponding Q_{gd} Equation
$V_{gd} < FC * VJ$	$Q_{gd} = \frac{CGD * VJ * \left(1 - \left(1 - \frac{V_{gd}}{VJ} \right)^{1-MG} \right)}{1 - MG}$
$V_{gd} \geq FC * VJ$	$Q_{gd} = CGD * \left(F1 + \frac{F3 * (V_{gd} - FC * VJ) + \frac{MG * (V_{gd}^2 - (FC * VJ)^2)}{2 * VJ}}{F2} \right)$

Where:

- **CGD** is the **Zero-bias GD capacitance**, **CGD** parameter value.

Temperature Dependence

Several transistor parameters depend on temperature. There are two ways to specify the transistor temperature:

- When you select `Device` temperature for the **Model temperature dependence using** parameter, the transistor temperature is

$$T = T_C + T_O$$

where:

- T_C is the **Circuit temperature** parameter value from the SPICE Environment Parameters block. If this block doesn't exist in the circuit, T_C is the default value of this parameter.
 - T_O is the **Offset local circuit temperature, TOFFSET** parameter value.
- When you select `Fixed` temperature for the **Model temperature dependence using** parameter, the transistor temperature is the **Fixed circuit temperature, TFIXED** parameter value.

The block provides the following relationship between the saturation current IS and the transistor temperature T :

$$IS(T) = IS * \left(T / T_{meas} \right)^{\frac{XTI}{ND}} * e^{\left(\frac{T}{T_{meas}} - 1 \right) * \frac{EG}{V_t}}$$

where:

- IS is the **Saturation current, IS** parameter value.
- T_{meas} is the **Parameter extraction temperature, TMEAS** parameter value.
- XTI is the **Saturation current temperature exponent, XTI** parameter value.
- EG is the **Energy gap, EG** parameter value.

- $V_i = ND * k * T/q$
- ND is the **Emission coefficient**, **ND** parameter value.

The block provides the following relationship between the junction potential VJ and the transistor temperature T :

$$VJ(T) = VJ * \left(\frac{T}{T_{meas}} \right) - \frac{3 * k * T}{q} * \log \left(\frac{T}{T_{meas}} \right) - \left(\frac{T}{T_{meas}} \right) * EG_{T_{meas}} + EG_T$$

where:

- VJ is the **Junction potential VJ** parameter value.
- $EG_{T_{meas}} = 1.16eV - (7.02e - 4 * T_{meas}^2) / (T_{meas} + 1108)$
- $EG_T = 1.16eV - (7.02e - 4 * T^2) / (T + 1108)$

The block provides the following relationship between the gate-source junction capacitance CGS and the transistor temperature T :

$$CGS(T) = CGS * \left[1 + MG * \left(400e - 6 * (T - T_{meas}) - \frac{VJ(T) - VJ}{VJ} \right) \right]$$

where:

- CGS is the **Zero-bias GS capacitance**, **CGS** parameter value.

The block uses the $CGS(T)$ equation to calculate the gate-drain junction capacitance by substituting CGD (the **Zero-bias GD capacitance**, **CGD** parameter value) for CGS .

The block provides the following relationship between the forward and reverse beta and the transistor temperature T :

$$\beta(T) = \beta * \left(\frac{T}{T_{meas}} \right)$$

where β is the **Transconductance, BETA** parameter value.

Basic Assumptions and Limitations

The model is based on the following assumptions:

- The NJFET block does not support noise analysis.
- The NJFET block applies initial conditions across junction capacitors and not across the block ports.

Dialog Box and Parameters

Main Tab

Block Parameters: NJFET
X

NJFET

This model approximates a SPICE N-channel JFET. You specify both model card and instance parameters as instance parameters on this mask. The instance parameter OFF and noise model parameters KF and AF are not supported. Additional instance parameters are SCALE, TOFFSET, ND, MG, XTI and EG.

SCALE is the number of parallel JFET instances for this device. SCALE multiplies the output current and device charge directly. This differs from the AREA parameter, which multiplies the device parameters BETA, IS, CGS, CGD, and divides RS and RD.

You can set the JFET temperature to a fixed temperature or to the circuit temperature (from the Custom Electrical Environment block) plus TOFFSET. The parameters ND, MG, XTI and EG adjust temperature sensitive parameters.

The block lets you include or exclude capacitance modeling and initial conditions. The capacitance modeling uses the published temperature equations, which may yield a slightly different value than SPICE for capacitance. The initial conditions ICVDS and ICVGS are the voltages across the internal junctions, and are only effective when the corresponding junction capacitances are present.

Parameters

Main | Junction Capacitance | Temperature

Device area, AREA:	<input style="width: 100%;" type="text" value="1"/>	<input style="width: 100%;" type="text" value="m^2"/>
Number of parallel devices, SCALE:	<input style="width: 100%;" type="text" value="1"/>	
Threshold voltage, VTO:	<input style="width: 100%;" type="text" value="-2"/>	<input style="width: 100%;" type="text" value="V"/>
Transconductance, BETA:	<input style="width: 100%;" type="text" value="1e-04"/>	<input style="width: 100%;" type="text" value="A/m^2/V^2"/>
Channel modulation, LAMBDA:	<input style="width: 100%;" type="text" value="0"/>	<input style="width: 100%;" type="text" value="1/V"/>
Saturation current, IS:	<input style="width: 100%;" type="text" value="1e-14"/>	<input style="width: 100%;" type="text" value="A/m^2"/>
Emission coefficient, ND:	<input style="width: 100%;" type="text" value="1"/>	
Source resistance, RS:	<input style="width: 100%;" type="text" value="0"/>	<input style="width: 100%;" type="text" value="m^2*Ohm"/>
Drain resistance, RD:	<input style="width: 100%;" type="text" value="0"/>	<input style="width: 100%;" type="text" value="m^2*Ohm"/>

Device area, AREA

The transistor area. This value multiplies the **Transconductance, BETA**, **Zero-bias GS capacitance, CGS**, **Zero-bias GD capacitance, CGD**, and **Saturation current, IS** parameter values. It divides the **Source resistance, RS** and **Drain resistance, RD** parameter values. The default value is 1 m². The value must be greater than 0.

Number of parallel devices, SCALE

The number of parallel transistors the block represents. This value multiplies the output current and device charges. The default value is 1. The value must be greater than 0.

Threshold voltage, VTO

The gate-source voltage above which the transistor produces a nonzero drain current. The default value is -2 V.

Transconductance, BETA

The derivative of drain current with respect to gate voltage. The default value is 1e-04 A/m²/V². The value must be greater than or equal to 0.

Channel modulation, LAMBDA

The channel-length modulation. The default value is 0 1/V.

Saturation current, IS

The magnitude of the current that the ideal diode equation approaches asymptotically for very large reverse bias levels. The default value is 1e-14 A/m². The value must be greater than or equal to 0.

Emission coefficient, ND

The transistor emission coefficient or ideality factor. The default value is 1. The value must be greater than 0.

Source resistance, RS

The transistor source resistance. The default value is 0 m²*Ω. The value must be greater than or equal to 0.

Drain resistance, RD

The transistor drain resistance. The default value is 0 m²*Ω. The value must be greater than or equal to 0.

Junction Capacitance Tab

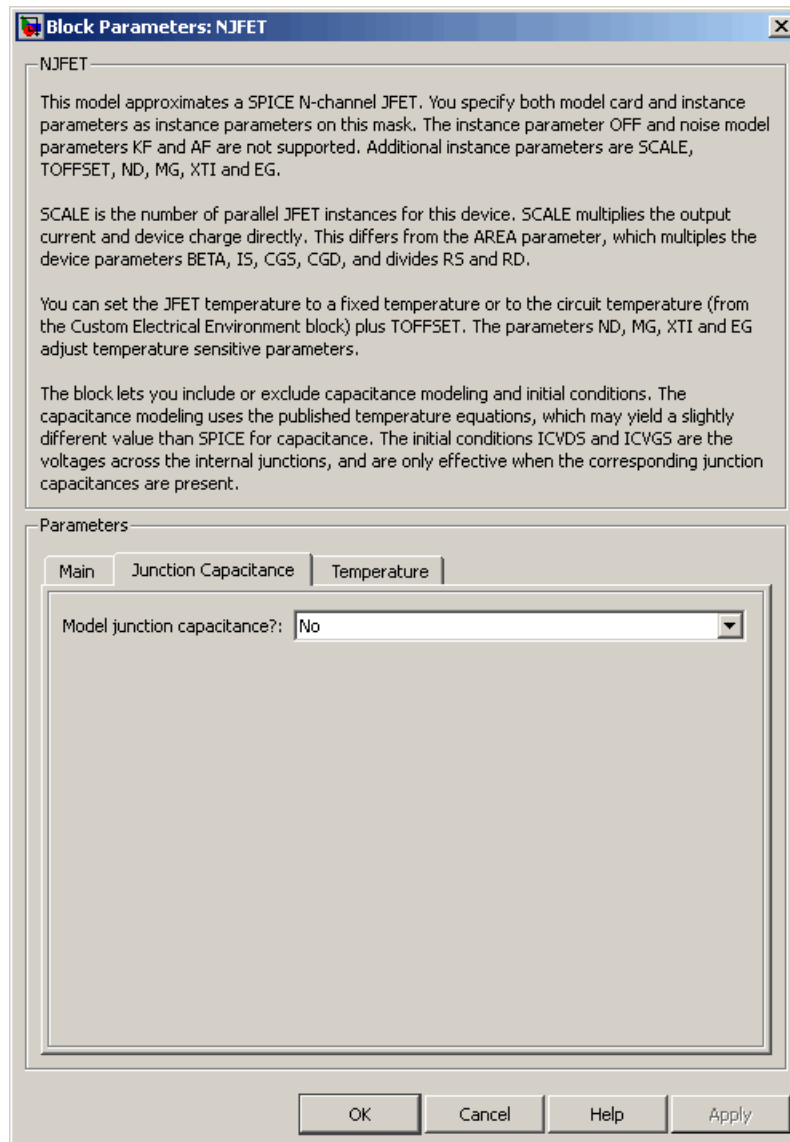

Model junction capacitance

Select one of the following options for modeling the junction capacitance:

- **No** — Do not include junction capacitance in the model. This is the default option.
- **Yes** — Specify zero-bias junction capacitance, junction potential, grading coefficient, forward-bias depletion capacitance coefficient, and transit time.

Zero-bias GS capacitance, CGS

The value of the capacitance placed between the gate and the source. This parameter is only visible when you select **Yes** for the **Model junction capacitance** parameter. The default value is 0 F/m². The value must be greater than or equal to 0.

Zero-bias GD capacitance, CGD

The value of the capacitance placed between the gate and the drain. This parameter is only visible when you select **Yes** for the **Model junction capacitance** parameter. The default value is 0 F/m². The value must be greater than or equal to 0.

Junction potential VJ

The junction potential. This parameter is only visible when you select **Yes** for the **Model junction capacitance** parameter. The default value is 1 V. The value must be greater than 0.01 V.

Grading coefficient, MG

The transistor grading coefficient. The default value is 0.5. The value must be greater than 0 and less than 0.9.

Capacitance coefficient FC

The fitting coefficient that quantifies the decrease of the depletion capacitance with applied voltage. This parameter is only visible when you select **Yes** for the **Model junction capacitance** parameter. The default value is 0.5. The value must be greater than or equal to 0 and less than or equal to 0.95.

Specify initial condition

Select one of the following options for specifying an initial condition:

- No — Do not specify an initial condition for the model. This is the default option.
- Yes — Specify the initial diode voltage.

Note The NJFET block applies the initial diode voltage across the junction capacitors and not across the ports.

Initial condition voltage ICVDS

Drain-source voltage at the start of the simulation. This parameter is only visible when you select **Yes** for the **Model junction capacitance** and **Yes** for the **Specify initial condition** parameter. The default value is 0 V.

Initial condition voltage ICVGS

Gate-source voltage at the start of the simulation. This parameter is only visible when you select **Yes** for the **Model junction capacitance** and **Yes** for the **Specify initial condition** parameter. The default value is 0 V.

Temperature Tab

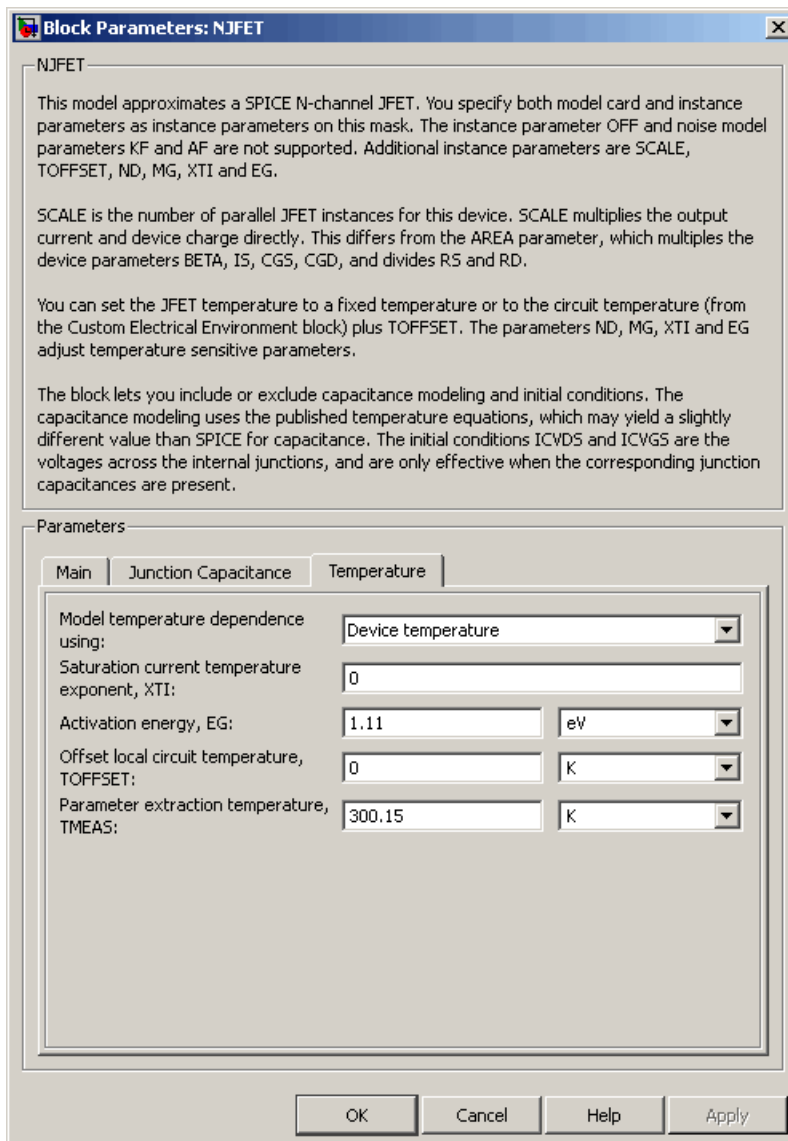

Model temperature dependence using

Select one of the following options for modeling the diode temperature dependence:

- **Device temperature** — Use the device temperature, which is the **Circuit temperature** value plus the **Offset local circuit temperature, TOFFSET** value. The **Circuit temperature** value comes from the SPICE Environment Parameters block, if one exists in the circuit. Otherwise, it comes from the default value for this block.
- **Fixed temperature** — Use a temperature that is independent of the circuit temperature to model temperature dependence.

Saturation current temperature exponent, XTI

The order of the exponential increase in the saturation current as temperature increases. The default value is 0. The value must be greater than or equal to 0.

Activation energy, EG

The energy gap that affects the increase in the saturation current as temperature increases. The default value is 1.11 eV. The value must be greater than 0.1 eV.

Offset local circuit temperature, TOFFSET

The amount by which the transistor temperature differs from the circuit temperature. This parameter is only visible when you select **Device temperature** for the **Model temperature dependence using** parameter. The default value is 0 K.

Fixed circuit temperature, TFIXED

The temperature at which to simulate the transistor. This parameter is only visible when you select **Fixed temperature** for the **Model temperature dependence using** parameter. The default value is 300.15 K. The value must be greater than 0.

Parameter extraction temperature, TMEAS

The temperature at which the transistor parameters were measured. The default value is 300.15 K. The value must be greater than 0.

Ports

The block has the following ports:

G

Electrical conserving port associated with the transistor gate terminal.

D

Electrical conserving port associated with the transistor drain terminal.

S

Electrical conserving port associated with the transistor source terminal.

References

[1] G. Massobrio and P. Antognetti. *Semiconductor Device Modeling with SPICE*. 2nd Edition, McGraw-Hill, 1993. Chapter 3.

See Also

N-Channel JFET, PJFET

Purpose Model SPICE-compatible N-Channel MOSFET

Library SPICE-Compatible Semiconductors

Description The NMOS block represents a SPICE-compatible N-channel MOSFET.

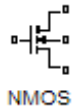

The NMOS block model includes the following components:

- “Resistance Calculations” on page 2-196
- “Bulk-Source Diode Model” on page 2-197
- “Bulk-Drain Diode Model” on page 2-198
- “Level 1 Drain Current Model” on page 2-199
- “Level 3 Drain Current Model” on page 2-202
- “Junction Charge Model” on page 2-208
- “Temperature Dependence” on page 2-213

Resistance Calculations

The following table shows how the NMOS block calculates the transistor drain resistance. The abbreviations in the table represent the values of the following block parameters:

- Drain resistance, RD
- Sheet resistance, RSH
- Number of drain squares, NRD

Drain resistance, RD Parameter	Sheet resistance, RSH Parameter	Drain Resistance
NaN	NaN	0
RD	NaN or RSH	RD
NaN	RSH	$RSH*NRD$

The following table shows how the NMOS block calculates the transistor source resistance. The abbreviations in the table represent the values of the following block parameters:

- **Source resistance, RS**
- **Sheet resistance, RSH**
- **Number of source squares, NRS**

Source resistance, RS Parameter	Sheet resistance, RSH Parameter	Source Resistance
NaN	NaN	0
RS	NaN or RSH	RS
NaN	RSH	RSH*NRS

Bulk-Source Diode Model

The block provides the following relationship between the bulk-source current I_{bs} and the bulk-source voltage V_{bs} after adjusting the applicable model parameters for temperature.

Applicable Range of V_{bs} Values	Corresponding I_{gs} Equation
$V_{bs} > 80 * V_{tn}$	$I_{bs} = IS_{bs} * \left(\left(\frac{V_{bs}}{V_{tn}} - 79 \right) e^{80} - 1 \right) + V_{bs} * G \text{ min}$
$80V_{tn} \geq V_{bs}$	$I_{bs} = IS_{bs} * \left(e^{V_{bs}/V_m} - 1 \right) + V_{bs} * G \text{ min}$

Where:

- IS_{bs} is
 - The product of the **Bulk jct sat current density, JS** parameter value and the **Area of source, AS** parameter value if both these

parameter values and the **Area of drain, AD** parameter value are nonzero.

- The **Bulk saturation current, IS** parameter value, otherwise.
- $V_{in} = NkT/q$
- q is the elementary charge on an electron, 1.6021918e-19 C.
- N is the **Emission coefficient, ND** parameter value.
- k is the Boltzmann constant.
- T is the diode temperature:
 - If you select Device temperature for the **Model temperature dependence using** parameter, T is the sum of the **Circuit temperature** value plus the **Offset local circuit temperature, TOFFSET** parameter value. The **Circuit temperature** value comes from the SPICE Environment Parameters block, if one exists in the circuit. Otherwise, it comes from the default value for this block.
 - If you select Fixed temperature for the **Model temperature dependence using** parameter, T is the **Fixed circuit temperature, TFIXED** parameter value.
- $GMIN$ is the diode minimum conductance. By default, $GMIN$ matches the **Minimum conductance GMIN** parameter of the SPICE Environment Parameters block, whose default value is 1e-12. To change $GMIN$, add a SPICE Environment Parameters block to your model and set the **Minimum conductance GMIN** parameter to the desired value.

Bulk-Drain Diode Model

The block provides the following relationship between the bulk-drain current I_{bd} and the bulk-drain voltage V_{bd} after adjusting the applicable model parameters for temperature.

Applicable Range of V_{bs} Values	Corresponding I_{gs} Equation
$V_{bd} > 80 * V_{tn}$	$I_{bd} = IS_{bd} * \left(\left(\frac{V_{bd}}{V_{tn}} - 79 \right) e^{80} - 1 \right) + V_{bd} * G \text{ min}$
$80V_{tn} \geq V_{bd}$	$I_{bd} = IS_{bd} * \left(e^{V_{bd}/V_{tn}} - 1 \right) + V_{bd} * G \text{ min}$

Where:

- IS_{bd} is
 - The product of the **Bulk jct sat current density, JS** parameter value and the **Area of drain, AD** parameter value if both these parameter values and the **Area of source, AS** parameter value are nonzero.
 - The **Bulk saturation current, IS** parameter value, otherwise.

Level 1 Drain Current Model

The block provides the following relationship between the drain current

I_d and the drain-source voltage V_{ds} in normal mode ($V_{ds} \geq 0$) after adjusting the applicable model parameters for temperature.

Normal Mode

Applicable Range of V_{gs} and V_{ds} Values	Corresponding I_d Equation
$V_{gs} - V_{on} \leq 0$	$I_d = 0$

Normal Mode (Continued)

Applicable Range of V_{gs} and V_{ds} Values	Corresponding I_d Equation
$0 < V_{gs} - V_{on} \leq V_{ds}$	$I_d = BETA * (V_{gs} - V_{on})^2 \frac{(1 + LAMBDA * V_{ds})}{2}$
$0 < V_{ds} < V_{gs} - V_{on}$	$I_d = BETA * V_{ds} \left((V_{gs} - V_{on}) - \frac{V_{ds}}{2} \right) (1 + LAMBDA * V_{ds})$

Where:

- V_{on} is:
 - $MTYPE * VBI + GAMMA \sqrt{PHI - V_{bs}}$ if $V_{bs} \leq 0$.
 - $MTYPE * VBI + GAMMA \left(\sqrt{PHI} - \frac{V_{bs}}{2\sqrt{PHI}} \right)$ if $0 < V_{bs} \leq 2 * PHI$.
 - $MTYPE * VBI$ if $V_{bs} > 2 * PHI$.
- $MTYPE$ is 1.
- $BETA$ is $KP * WIDTH / (LENGTH - 2 * LD)$
- KP is:
 - The **Transconductance, KP** parameter value, if this parameter has a numerical value.
 - $U0 * 3.9 * \epsilon_0 / TOX$, if **Transconductance, KP** is NaN and you specify values for both the **Oxide thickness, TOX** and **Substrate doping, NSUB** parameters.
- $WIDTH$ is the **Width of channel, WIDTH** parameter value.

- *LENGTH* is the **Length of channel**, **LENGTH** parameter value.
- *LD* is the **Lateral diffusion**, **LD** parameter value.
- *VBI* is an built-in voltage value the block uses in calculations. The value is a function of temperature. For a detailed definition, see “Temperature Dependence” on page 2-213.
- *PHI* is:
 - The **Surface potential**, **PHI** parameter value, if this parameter has a numerical value.
 - $2 * kT_{meas} / q * \log(NSUB / n_i)$, if **Surface potential**, **PHI** is NaN and you specify values for both the **Oxide thickness**, **TOX** and **Substrate doping**, **NSUB** parameters.
- *LAMBDA* is the **Channel modulation**, **LAMBDA** parameter value.
- *GAMMA* is:
 - The **Bulk threshold**, **GAMMA** parameter value, if this parameter has a numerical value.
 - $TOX * \sqrt{2 * 11.7 * \epsilon_0 * q * NSUB} / (3.9 * \epsilon_0)$, if **Bulk threshold**, **GAMMA** is NaN and you specify values for both the **Oxide thickness**, **TOX** and **Substrate doping**, **NSUB** parameters.
- ϵ_0 is the permittivity of free space, 8.854214871e-12 F/m.
- n_i is the carrier concentration of intrinsic silicon, 1.45e10 cm⁻³.

The block provides the following relationship between the drain current

I_d and the drain-source voltage V_{ds} in inverse mode ($V_{ds} < 0$) after adjusting the applicable model parameters for temperature.

Inverse Mode

Applicable Range of V_{gd} and V_{ds} Values	Corresponding I_d Equation
$V_{gd} - V_{on} \leq 0$	$I_d = 0$
$0 < V_{gd} - V_{on} \leq -V_{ds}$	$I_d = -BETA(V_{gd} - V_{on})^2(1 - LAMBDA * V_{ds})/2$
$0 < V_{ds} < V_{gd} - V_{on}$	$I_d = BETA * V_{ds} \left((V_{gd} - V_{on}) + V_{ds}/2 \right) (1 - LAMBDA * V_{ds})$

Where:

- V_{on} is:
 - $MTYPE * VBI + GAMMA \sqrt{PHI - V_{bd}}$ if $V_{bd} \leq 0$.
 - $MTYPE * VBI + GAMMA \left(\sqrt{PHI} - \frac{V_{bd}}{2\sqrt{PHI}} \right)$ if $0 < V_{bd} \leq 2 * PHI$.
 - $MTYPE * VBI$ if $V_{bd} > 2 * PHI$.

Level 3 Drain Current Model

The block provides the following model for drain current I_{ds} in normal mode ($V_{ds} \geq 0$) after adjusting the applicable model parameters for temperature.

$$I_{DS} = I_{DS0} * Scale_{VMAX} * Scale_{LChan} * Scale_{INV}$$

Where:

- I_{DS0} is the Basic Drain Current Model.

- $Scale_{VMAX}$ is the Velocity Saturation Scaling.
- $Scale_{LChan}$ is the Channel Length Modulation Scaling.
- $Scale_{INV}$ is the Weak Inversion Scaling.

The blocks uses the same model for drain current in inverse mode ($V_{ds} < 0$), with the following substitutions:

- $V_{bs} - V_{ds}$ for V_{bs}
- $V_{gs} - V_{ds}$ for V_{ds}
- $-V_{ds}$ for V_{ds}

Basic Drain Current Model

The block provides the following relationship between the drain current I_{ds} and the drain-source voltage V_{ds} :

$$I_{DS0} = BETA * F_{gate} * \left(V_{GSX} - V_{TH} - \frac{1 + F_B}{2} * V_{DSX} \right) * V_{DSX}$$

- The block calculates BETA as described in “Level 1 Drain Current Model” on page 2-199.
- The block calculates F_{GATE} using the following equation:

$$F_{gate} = \frac{1}{1 + THETA * (V_{gsx} - V_{TH})}$$

- **THETA** is the **Vgs dependence on mobility**, **THETA** parameter value.
- $V_{gsx} = \max(V_{GS}, V_{on})$
- If you specify a nonzero value for the **Fast surface state density**, **NFS** parameter, the block calculates V_{on} using the following equation:

$$V_{on} = V_{TH} + x_n V_T$$

Otherwise, $V_{on} = V_{TH}$.

- The block calculates x_n using the following equation:

$$x_n = 1 + \frac{q * NFS}{COX} + \frac{\left(GAMMA * F_s * \sqrt{V_{bulk}} + \frac{F_n * V_{bulk}}{WIDTH} \right)}{2 * V_{bulk}}$$

- The block calculates V_{bulk} as follows:
 - If $V_{BS} \leq 0$, $V_{bulk} = PHI - V_{BS}$.
 - Otherwise, the block calculates V_{bulk} using the following equation:

$$V_{bulk} = \frac{PHI}{\left(1 + \frac{V_{BS}}{2 * PHI} \right)^2}$$

- $V_T = kT/q$
- The block calculates V_{TH} using the equation following equation:

$$V_{TH} = V_{BI} - \frac{8.15e^{-22} * ETA}{COX * (LENGTH - 2 * LD)^3} * V_{DS} + GAMMA * F_s * \sqrt{V_{bulk}} + F_n * V_{bulk}$$

- For information about how the block calculates V_{BI} , see “Temperature Dependence” on page 2-213.
- **ETA** is the **Vds dependence threshold volt**, **ETA** parameter value.
- $COX = \epsilon_{ox}/TOX$, where ϵ_{ox} is the permittivity of the oxide and **TOX** is the **Oxide thickness**, **TOX** parameter value.

- If you specify a nonzero value for the **Junction depth, XJ** parameter and a value for the **Substrate doping, NSUB** parameter, the block calculates F_s using the following equations:

$$\alpha = \frac{2\varepsilon_{si}}{qNSUB}$$

$$XD = \sqrt{\alpha}$$

$$wc = .0631353 + .8013292 * \frac{XD * \sqrt{V_{bulk}}}{XJ}$$

$$-.01110777 * \left(\frac{XD * \sqrt{V_{bulk}}}{XJ} \right)^2 + \frac{LD}{XJ}$$

$$F_s = 1 - \left(wc * \sqrt{1 - \left(\frac{XD * \sqrt{V_{bulk}}}{XJ + XD * \sqrt{V_{bulk}}} \right)^2} - \frac{LD}{XJ} \right)$$

where ε_{si} is the permittivity of silicon.

Otherwise, $F_s = 1$.

- The block calculates F_B using the following equation:

$$F_B = \frac{GAMMA * F_s}{4 * \sqrt{V_{bulk}}} + F_n$$

- The block calculates F_n using the following equation:

$$F_n = \frac{DELTA * \pi * \varepsilon_{si}}{2 * COX * WIDTH}$$

- $DELTA$ is the **Width effect on threshold, DELTA** parameter value.

- V_{DSX} is the lesser of V_{DS} and the saturation voltage, V_{dsat} .
 - If you specify a positive value for the **Max carrier drift velocity**, **VMAX** parameter, the block calculates V_{dsat} using the following equation:

$$V_{dsat} = \frac{V_{gsx} - V_{TH}}{1 + F_B} + \frac{(LENGTH - 2 * LD) * VMAX}{UO * F_{gate}}$$

$$- \sqrt{\left(\frac{V_{gsx} - V_{TH}}{1 + F_B} \right)^2 + \left(\frac{(LENGTH - 2 * LD) * VMAX}{UO * F_{gate}} \right)^2}$$

Otherwise, the block calculates V_{dsat} using the following equation:

$$V_{dsat} = \frac{V_{gsx} - V_{TH}}{1 + F_B}$$

Velocity Saturation Scaling

If you specify a positive value for the **Max carrier drift velocity**, **VMAX** parameter, the block calculates $Scale_{VMAX}$ using the following equation:

$$Scale_{VMAX} = \frac{1}{1 + \frac{UO * F_{gate}}{(LENGTH - 2 * LD) * VMAX} * V_{DSX}}$$

Otherwise, $Scale_{VMAX} = 1$.

Channel Length Modulation Scaling

The block scales the drain current to account for channel length modulation if the block meets all of the following criteria:

- $V_{DS} > V_{sat}$

- The **Max carrier drift velocity**, **VMAX** parameter value is zero or α is nonzero.

The block scales the drain current using the following equation:

$$Scale_{LChan} = \frac{1}{1 - \frac{\Delta l}{(LENGTH - 2 * LD)}}$$

The block uses the following procedure to calculate Δl :

- 1 The block first calculates the intermediate value Δl_0 .
 - If you specify a positive value for the **Max carrier drift velocity**, **VMAX** parameter, the block computes the intermediate value g_{dsat} as the greater of 1e-12 and the result of the following equation:

$$I_{DS0} * \left(1 - \frac{1}{1 + Scale_{g_{dsat}} * V_{DSX}} \right) * Scale_{g_{dsat}}$$

where:

$$Scale_{g_{dsat}} = \frac{UO * F_{gate}}{(LENGTH - 2 * LD) * VMAX}$$

Then, the block uses the following equation to calculate the intermediate value Δl_0 :

$$\Delta l_0 = \sqrt{\left(\frac{KA * I_{DS}}{2 * (LENGTH - 2 * LD) * g_{dsat}} \right)^2 + KA * (V_{DS} - V_{dsat})} - \frac{KA * I_{DS}}{2 * (LENGTH - 2 * LD) * g_{dsat}}$$

where KA is the product of the **Mobility modulation, KAPPA** parameter value and a .

- Otherwise, the block uses the following equation to calculate the intermediate value Δl_0 :

$$\Delta l = \sqrt{KA * (V_{DS} - V_{dsat})}$$

2 The block checks for punch through and calculates Δl .

- If Δl_0 is greater than $(LENGTH - 2 * LD) / 2$, the block calculates Δl using the following equation:

$$\Delta l = \left(1 - \frac{(LENGTH - 2 * LD)}{4 * \Delta l_0} \right) * (LENGTH - 2 * LD)$$

- Otherwise, $\Delta l = \Delta l_0$.

Weak Inversion Scaling

If V_{GS} is less than V_{on} , the block calculates $Scale_{INV}$ using the following equation:

$$Scale_{INV} = e^{\frac{V_{gs} - V_{on}}{x_n * V_T}}$$

Otherwise, $Scale_{INV} = 1$.

Junction Charge Model

The block models the following junction charges:

- Junction Overlap Charges
- Bulk Junction Charges

Junction Overlap Charges

The block calculates the following junction overlap charges:

- $Q_{GS} = CGSO * WIDTH * V_{gs}$

Where:

- Q_{GS} is the gate-source overlap charge.
- $CGSO$ is the **G-S overlap capacitance**, **CGSO** parameter value.
- $WIDTH$ is the **Width of channel**, **WIDTH** parameter value.

- $Q_{GD} = CGDO * WIDTH * V_{gd}$

Where:

- Q_{GD} is the gate-drain overlap charge.
- $CGDO$ is the **G-D overlap capacitance**, **CGDO** parameter value.

- $Q_{GB} = CGBO * (LENGTH - 2 * LD) * V_{gb}$

Where:

- Q_{GB} is the gate-bulk overlap charge.
- $CGBO$ is the **G-B overlap capacitance**, **CGBO** parameter value.
- $LENGTH$ is the **Length of channel**, **LENGTH** parameter value.
- LD is the **Lateral diffusion**, **LD** parameter value.

Bulk Junction Charges

The block provides the following relationship between the bulk-drain bottom junction charge Q_{bottom} and the junction voltage V_{bd} after adjusting the applicable model parameters for temperature.

NMOS

Applicable Range of V_{bd} Values	Corresponding Q_{bottom} Equation
$V_{bd} < FC * PB$	$Q_{bottom} = \frac{CBD * PB * \left(1 - \left(1 - \frac{V_{bd}}{PB}\right)^{1-MJ}\right)}{1 - MJ} \quad \text{if } CBD > 0.$ $Q_{bottom} = \frac{CJ * AD * PB * \left(1 - \left(1 - \frac{V_{bd}}{PB}\right)^{1-MJ}\right)}{1 - MJ} \quad \text{otherwise.}$
$V_{bd} \geq FC * PB$	$Q_{bottom} = CBD *$ $\left(F1 + \frac{F3 * (V_{bd} - FC * PB) + \frac{MJ * (V_{bd}^2 - (FC * PB)^2)}{2 * PB}}{F2} \right)$ <p>if $CBD > 0$.</p> $Q_{bottom} = CJ * AD *$ $\left(F1 + \frac{F3 * (V_{bd} - FC * PB) + \frac{MJ * (V_{bd}^2 - (FC * PB)^2)}{2 * PB}}{F2} \right)$ <p>otherwise.</p>

Where:

- *PB* is the **Bulk junction potential, PB** parameter value.
- *FC* is the **Capacitance coefficient FC** parameter value.
- *CBD* is the **Zero-bias BD capacitance, CBD** parameter value.
- *CJ* is the **Bottom junction cap per area, CJ** parameter value.
- *AD* is the **Area of drain, AD** parameter value.
- *MJ* is the **Bottom grading coefficient, MJ** parameter value.

- $$F1 = \frac{PB * (1 - (1 - FC)^{1-MJ})}{1 - MJ}$$
- $$F2 = (1 - FC)^{1+MJ}$$
- $$F3 = 1 - FC * (1 + MJ)$$

The block uses the equations in the preceding table to calculate the bulk-source bottom junction charge, with the following substitutions:

- V_{bs} replaces V_{bd} .
- *AS* (the **Area of source, AS** parameter value) replaces *AD*.
- *CBS* (the **Zero-bias BS capacitance, CBS** parameter value) replaces *CBD*.

The block provides the following relationship between the bulk-drain sidewall junction charge $Q_{sidewall}$ and the junction voltage V_{bd} after adjusting the applicable model parameters for temperature.

Applicable Range of V_{bd} Values	Corresponding $Q_{sidewall}$ Equation
$V_{bd} < FC * PB$	$Q_{sidewall} = \frac{CJSW * PD * PB * \left(1 - \left(1 - \frac{V_{bd}}{PB} \right)^{1-MGSW} \right)}{1 - MGSW}$
$V_{bd} \geq FC * PB$	$Q_{sidewall} = CJSW * PD * \left(F1 + \frac{F3 * (V_{bd} - FC * PB) + \frac{MGSW * (V_{bd}^2 - (FC * PB)^2)}{2 * PB}}{F2} \right)$

Where:

- $CJSW$ is the **Side jct cap/area of jct perimeter**, $CJSW$ parameter value.
- PD is the **Perimeter of drain**, AD parameter value.
- $MGSW$ is the **Side grading coefficient**, $MJSW$ parameter value.

- $F1 = \frac{PB * (1 - (1 - FC)^{1-MJSW})}{1 - MJSW}$
- $F2 = (1 - FC)^{1+MJSW}$
- $F3 = 1 - FC * (1 + MJSW)$

The block uses the equations in the preceding table to calculate the bulk-source sidewall junction charge and the sidewall junction voltage, with the following substitutions:

- V_{bs} replaces V_{bd} .
- PS (the **Perimeter of source, PS** parameter value) replaces PD .

Temperature Dependence

Several transistor parameters depend on temperature. There are two ways to specify the transistor temperature:

- When you select `Device` temperature for the **Model temperature dependence using** parameter, the transistor temperature is

$$T = T_C + T_O$$

where:

- T_C is the **Circuit temperature** parameter value from the SPICE Environment Parameters block. If this block doesn't exist in the circuit, T_C is the default value of this parameter.
- T_O is the **Offset local circuit temperature, TOFFSET** parameter value.
- When you select `Fixed` temperature for the **Model temperature dependence using** parameter, the transistor temperature is the **Fixed circuit temperature, TFIXED** parameter value.

The block provides the following relationship between the transconductance KP and the transistor temperature T :

$$KP(T) = \frac{KP}{\left(\frac{T}{T_{meas}}\right)^{3/2}}$$

where:

- KP is the **Transconductance, KP** parameter value.
- T_{meas} is the **Parameter extraction temperature, TMEAS** parameter value.

The block provides the following relationship between the surface potential PHI and the transistor temperature T :

$$PHI(T) = \frac{T}{T_{meas}} \left(PHI + \frac{kT_{meas}}{q} \left(\log \left(\frac{T_{meas}}{300.15} \right)^3 + \frac{q}{k} \left(\frac{1.115}{300.15} - \frac{EG_{T_{meas}}}{T_{meas}} \right) \right) \right) - \frac{kT}{q} \left(\log \left(\frac{T}{300.15} \right)^3 + \frac{q}{k} \left(\frac{1.115}{300.15} - \frac{EG_T}{T} \right) \right)$$

where:

- $EG_{T_{meas}} = 1.16eV - (7.02e - 4 * T_{meas}^2) / (T_{meas} + 1108)$
- $EG_T = 1.16eV - (7.02e - 4 * T^2) / (T + 1108)$

The block provides the following relationship between the built-in voltage VBI and the transistor temperature T :

$$VBI(T) = VTO + MTYPE * \left(\frac{PHI(T) - PHI}{2} - GAMMA \sqrt{PHI} \right) + \frac{EG_{T_{meas}} - EG_T}{2}$$

where:

- VTO is:
 - The **Threshold voltage, VTO** parameter value, if this parameter has a numerical value.

- $\Phi - 3.25 + EG_{T_{meas}} / 2 + MTYPE * PHI / 2 - NSS * q * TOX / (3.9 * \epsilon_0)$
 $+ MTYPE * (GAMMA * \sqrt{PHI + PHI})$, if **Threshold voltage**, **VTO** is NaN and you specify values for both the **Oxide thickness**, **TOX** and **Substrate doping**, **NSUB** parameters.
- Φ is:
 - 3.2, if **TPG** (the **Gate type?**, **TPG** parameter value) is 0.
 - $3.25 + EG_{T_{meas}} / 2 - MTYPE * TPG * EG_{T_{meas}} / 2$, otherwise.
- **GAMMA** is:
 - The **Bulk threshold**, **GAMMA** parameter value, if this parameter has a numerical value.
 - $TOX * \sqrt{2 * 11.7 * \epsilon_0 * q * NSUB} / (3.9 * \epsilon_0)$, if **Bulk threshold**, **GAMMA** is NaN and you specify values for both the **Oxide thickness**, **TOX** and **Substrate doping**, **NSUB** parameters.

The block provides the following relationship between the bulk saturation current IS and the transistor temperature T :

$$IS(T) = IS * e^{\frac{-qEG_T}{ND*kT} + \frac{qEG_{T_{meas}}}{ND*kT_{meas}}}$$

where:

- ND is the **Emission coefficient**, **ND** parameter value.
- IS is the **Bulk saturation current**, **IS** parameter value.

The block provides the following relationship between the bulk junction saturation current density JS and the transistor temperature T :

$$JS(T) = JS * e^{\frac{-qEG_T}{ND*kT} + \frac{qEG_{T_{meas}}}{ND*kT_{meas}}}$$

where:

- JS is the **Bulk jct sat current density**, **JS** parameter value.

The block provides the following relationship between the bulk junction potential PB and the transistor temperature T :

$$PB(T) = \frac{PB + \frac{kT_{meas}}{q} \left(\log \left(\frac{T_{meas}}{300.15} \right)^3 + \frac{q}{k} \left(\frac{1.115}{300.15} - \frac{EG_{T_{meas}}}{T} \right) \right)}{T_{meas}/T} - \frac{kT}{q} \left(\log \left(\frac{T}{300.15} \right)^3 + \frac{q}{k} \left(\frac{1.115}{300.15} - \frac{EG_T}{T} \right) \right)$$

where:

- PB is the **Bulk junction potential**, **PB** parameter value.

The block provides the following relationship between the bulk-drain junction capacitance CBD and the transistor temperature T :

$$CBD(T) = CBD \frac{pbo + MJ * (4 * 10^4 * (T - 300.15) * pbo - (PB(T) - pbo))}{pbo + MJ * (4 * 10^4 * (T_{meas} - 300.15) * pbo - (PB - pbo))}$$

where:

- CBD is the **Zero-bias BD capacitance**, **CBD** parameter value.
- MJ is the **Bottom grading coefficient**, **MJ** parameter value.

$$pbo = \frac{PB + \frac{kT_{meas}}{q} \left(\log \left(\frac{T_{meas}}{300.15} \right)^3 + \frac{q}{k} \left(\frac{1.115}{300.15} - \frac{EG_{T_{meas}}}{T} \right) \right)}{T_{meas}/300.15}$$

The block uses the $CBD(T)$ equation to calculate:

- The bulk-source junction capacitance by substituting CBS (the **Zero-bias BS capacitance, CBS** parameter value) for CBD .
- The bottom junction capacitance by substituting CJ (the **Bottom junction cap per area, CJ** parameter value) for CBD .

The block provides the following relationship between the sidewall junction capacitance $CJSW$ and the transistor temperature T :

$$CJSW(T) = CJSW \frac{pbo + MJSW * (4 * 10^4 * (T - 300.15) * pbo - (PB(T) - pbo))}{pbo + MJSW * (4 * 10^4 * (T_{meas} - 300.15) * pbo - (PB - pbo))}$$

where:

- $MJSW$ is the **Side grading coefficient, MJSW** parameter value.

Basic Assumptions and Limitations

The model is based on the following assumptions:

- The NMOS block does not support noise analysis.
- The NMOS block applies initial conditions across junction capacitors and not across the block ports.

Dialog Box and Parameters

Model Selection Tab

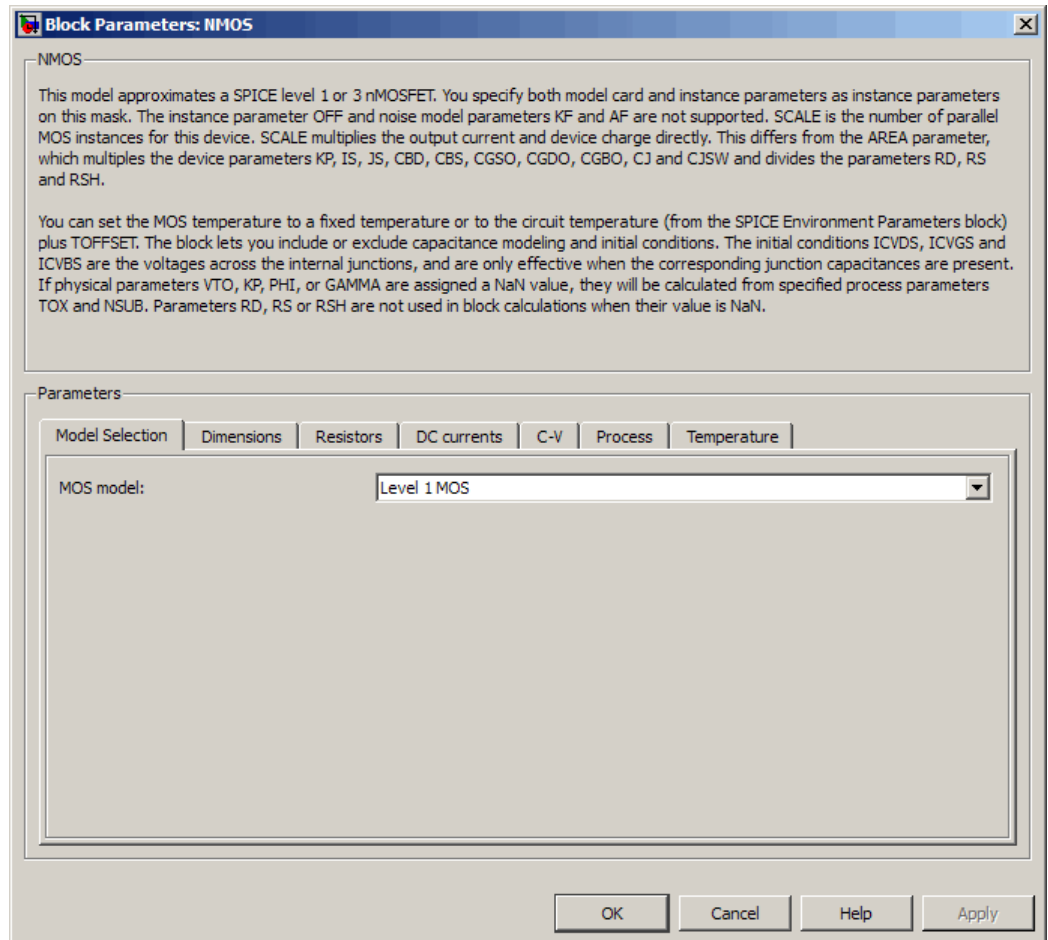

MOS model

Select one of the following MOSFET model options:

- Level 1 MOS — Use the “Level 1 Drain Current Model” on page 2-199. This is the default option.

- Level 3 MOS — Use the “Level 3 Drain Current Model” on page 2-202.

Dimensions Tab

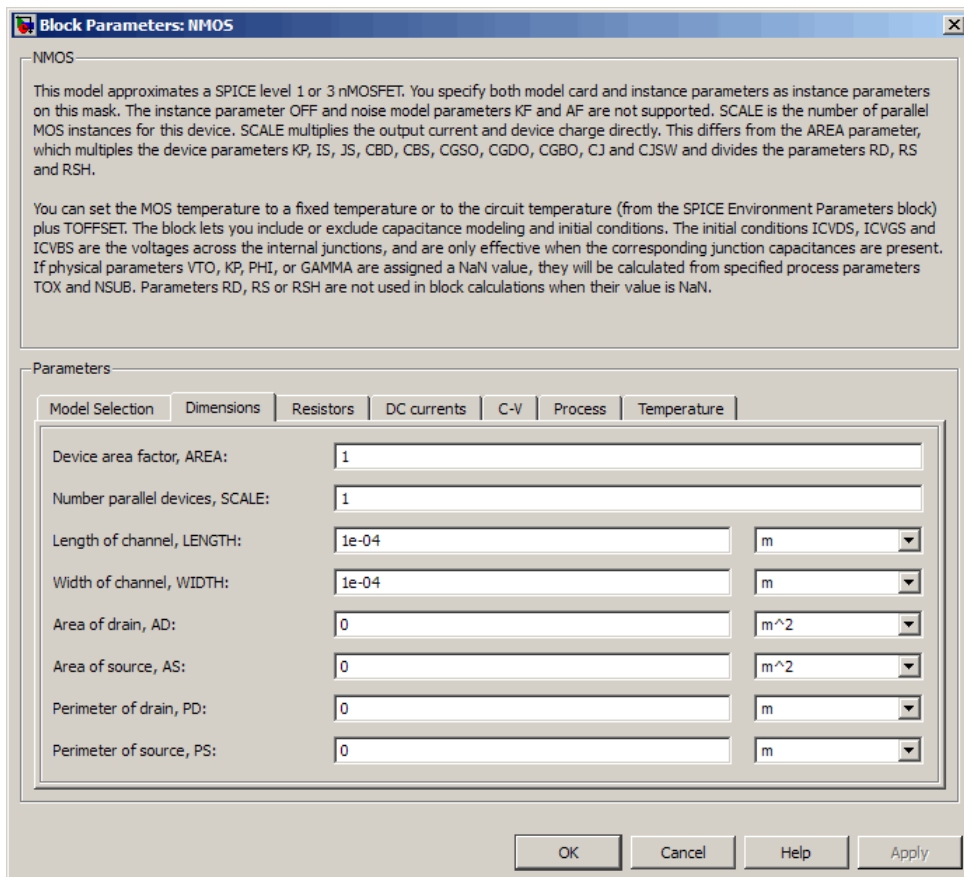

Device area factor, AREA

The transistor area. This value multiplies the following parameter values:

- **Transconductance, KP**
- **Bulk saturation current, IS**
- **Bulk jct sat current density, JS**
- **Zero-bias BD capacitance, CBD**
- **Zero-bias BS capacitance, CBS**
- **G-S overlap capacitance, CGSO**
- **G-D overlap capacitance, CGDO**
- **G-B overlap capacitance, CGBO**
- **Bottom junction cap per area CJ**
- **Side jct cap/area of jct perimeter CJSW**

It divides the following parameter values:

- **Drain resistance, RD**
- **Source resistance, RS**
- **Sheet resistance, RSH**

The default value is 1. The value must be greater than 0.

Number of parallel devices, SCALE

The number of parallel MOS instances for this device. This parameter multiplies the output current and device charge. The default value is 1. The value must be greater than 0.

Length of channel, LENGTH

Length of the channel between the source and drain. The default value is 1e-04 m.

Width of channel, WIDTH

Width of the channel between the source and drain. The default value is 1e-04 m.

Area of drain, AD

Area of the transistor drain diffusion. The default value is 0 m².
The value must be greater than or equal to 0.

Area of source, AS

Area of the transistor source diffusion. The default value is 0 m².
The value must be greater than or equal to 0.

Perimeter of drain, PD

Perimeter of the transistor drain diffusion. The default value
is 0 m.

Perimeter of source, PS

Perimeter of the transistor source diffusion. The default value
is 0 m.

Resistors Tab

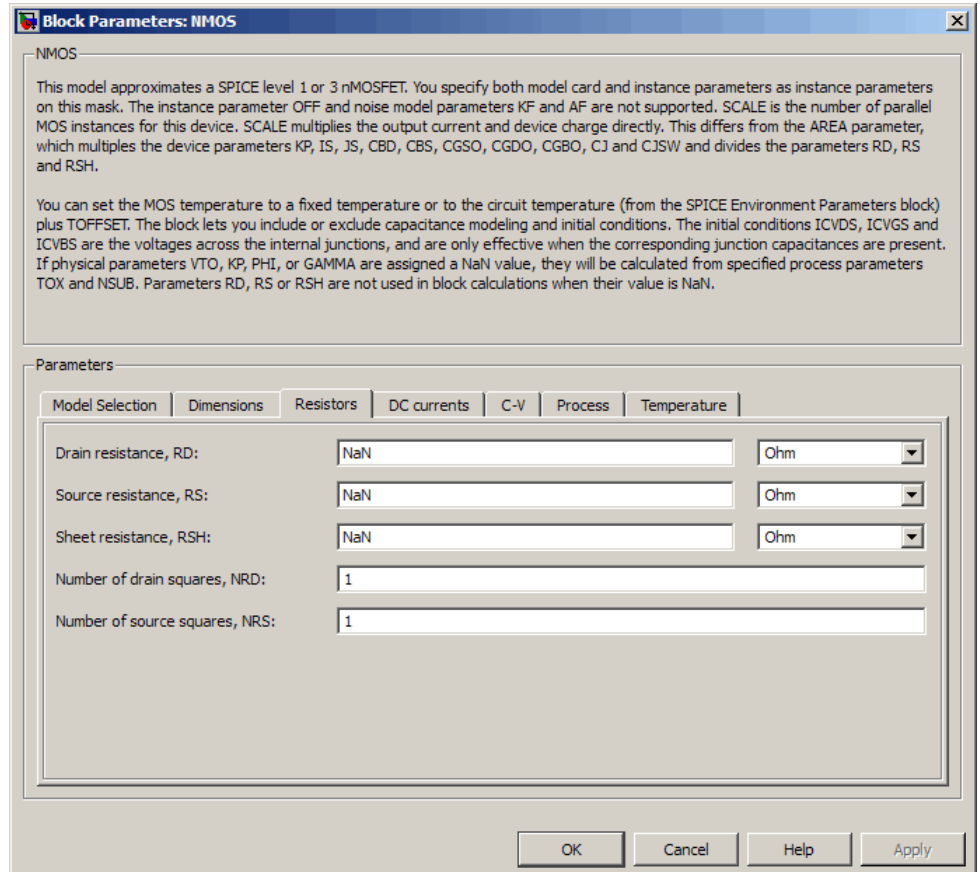

Drain resistance, RD

The transistor drain ohmic resistance. The default value is Nan Ω . This value means the parameter is unspecified, so the block calculates the drain resistance as described in “Resistance Calculations” on page 2-196. The value must be equal to 0 or

greater than or equal to R_{min} . R_{min} is a built-in model constant whose value is $1e-12$.

Source resistance, RS

The transistor source ohmic resistance. The default value is $Nan \Omega$. This value means the parameter is unspecified, so the block calculates the drain resistance as described in “Resistance Calculations” on page 2-196. The value must be equal to 0 or greater than or equal to R_{min} . R_{min} is a built-in model constant whose value is $1e-12$.

Sheet resistance, RSH

Resistance per square of the transistor source and drain. The default value is $Nan \Omega$. This value means the parameter is unspecified. The block only uses this parameter value if you do not specify one or both of the **Drain resistance, RD** and **Source resistance, RS** parameter values, as described in “Resistance Calculations” on page 2-196. The value must be greater than or equal to 0.

Number of drain squares, NRD

Number of squares of resistance that make up the transistor drain diffusion. The default value is 1. The value must be greater than or equal to 0. The block only uses this parameter value if you do not specify one or both of the **Drain resistance, RD** and **Source resistance, RS** parameter values, as described in “Resistance Calculations” on page 2-196.

Number of source squares, NRS

Number of squares of resistance that make up the transistor source diffusion. The default value is 1. The value must be greater than or equal to 0. The block only uses this parameter value if you do not specify one or both of the **Drain resistance, RD** and **Source resistance, RS** parameter values, as described in “Resistance Calculations” on page 2-196.

DC Currents Tab

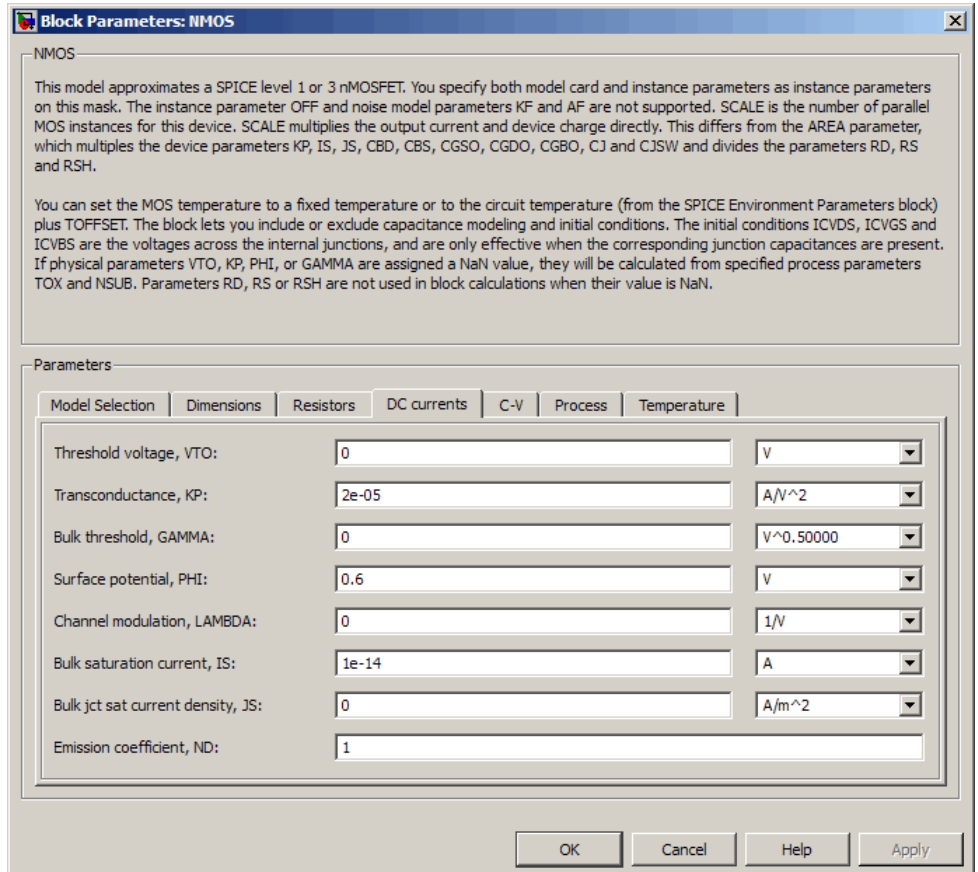

Threshold voltage, VTO

The gate-source voltage above which the transistor produces a nonzero drain current. The default value is 0 V. If you assign this parameter a value of NaN, the block calculates the value from the specified values of the **Oxide thickness, TOX** and **Substrate**

doping, NSUB parameters. For more information about this calculation, see “Temperature Dependence” on page 2-213.

Transconductance, KP

The derivative of drain current with respect to gate voltage. The default value is $2e-05$ A/V². The value must be greater than or equal to 0. If you assign this parameter a value of NaN, the block calculates the value from the specified values of the **Oxide thickness, TOX** and **Substrate doping, NSUB** parameters. For more information about this calculation, see “Level 1 Drain Current Model” on page 2-199 or “Level 3 Drain Current Model” on page 2-202 as appropriate for the selected value of the **MOS model** parameter.

Bulk threshold, GAMMA

Body effect parameter, which relates the threshold voltage, VTH, to the body bias, VBS, as described in “Level 1 Drain Current Model” on page 2-199 and “Level 3 Drain Current Model” on page 2-202. The default value is $0 \sqrt{V}$. The value must be greater than or equal to 0. If you assign this parameter a value of NaN, the block calculates the value from the specified values of the **Oxide thickness, TOX** and **Substrate doping, NSUB** parameters. For more information about this calculation, see “Level 1 Drain Current Model” on page 2-199 or “Level 3 Drain Current Model” on page 2-202 as appropriate for the selected value of the **MOS model** parameter.

Surface potential, PHI

Twice the voltage at which the surface electron concentration becomes equal to the intrinsic concentration and the device transitions between depletion and inversion conditions. The default value is 0.6 V. The value must be greater than or equal to 0. If you assign this parameter a value of NaN, the block calculates the value from the specified values of the **Oxide thickness, TOX** and **Substrate doping, NSUB** parameters. For more information about this calculation, see “Level 1 Drain Current Model” on page 2-199 or “Level 3 Drain Current Model” on page

2-202 as appropriate for the selected value of the **MOS model** parameter.

Channel modulation, LAMBDA

The channel-length modulation. This parameter is only visible when you select **Level 1 MOS** for the **MOS model** parameter. The default value is 0 1/V.

Bulk saturation current, IS

The magnitude of the current that the junction approaches asymptotically for very large reverse bias levels. The default value is 1e-14 A. The value must be greater than or equal to 0.

Bulk jct sat current density, JS

The magnitude of the current per unit area that the junction approaches asymptotically for very large reverse bias levels. The default value is 0 A/m². The value must be greater than or equal to 0.

Emission coefficient, ND

The transistor emission coefficient or ideality factor. The default value is 1. The value must be greater than 0.

Width effect on threshold, DELTA

The factor that controls the effect of transistor width on threshold voltage. This parameter is only visible when you select **Level 3 MOS** for the **MOS model** parameter. The default value is 0.

Max carrier drift velocity, VMAX

The maximum drift velocity of the carriers. This parameter is only visible when you select **Level 3 MOS** for the **MOS model** parameter. The default value is 0 m/s.

Fast surface state density, NFS

The fast surface state density adjusts the drain current for the mobility reduction caused by the gate voltage. This parameter is only visible when you select **Level 3 MOS** for the **MOS model** parameter. The default value is 0 1/cm².

Vds dependence threshold volt, ETA

The coefficient that controls how the threshold voltage depends on the drain-source voltage in the drain current calculation. This parameter is only visible when you select Level 3 MOS for the **MOS model** parameter. The default value is 0.

Vgs dependence on mobility, THETA

The coefficient that controls how the mobility affects the gate voltage in the drain current calculation. This parameter is only visible when you select Level 3 MOS for the **MOS model** parameter. The default value is 0 1/V.

Mobility modulation, KAPPA

The coefficient that controls how the mobility affects the channel length in the drain current calculation. This parameter is only visible when you select Level 3 MOS for the **MOS model** parameter. The default value is 0.2.

C-V Tab

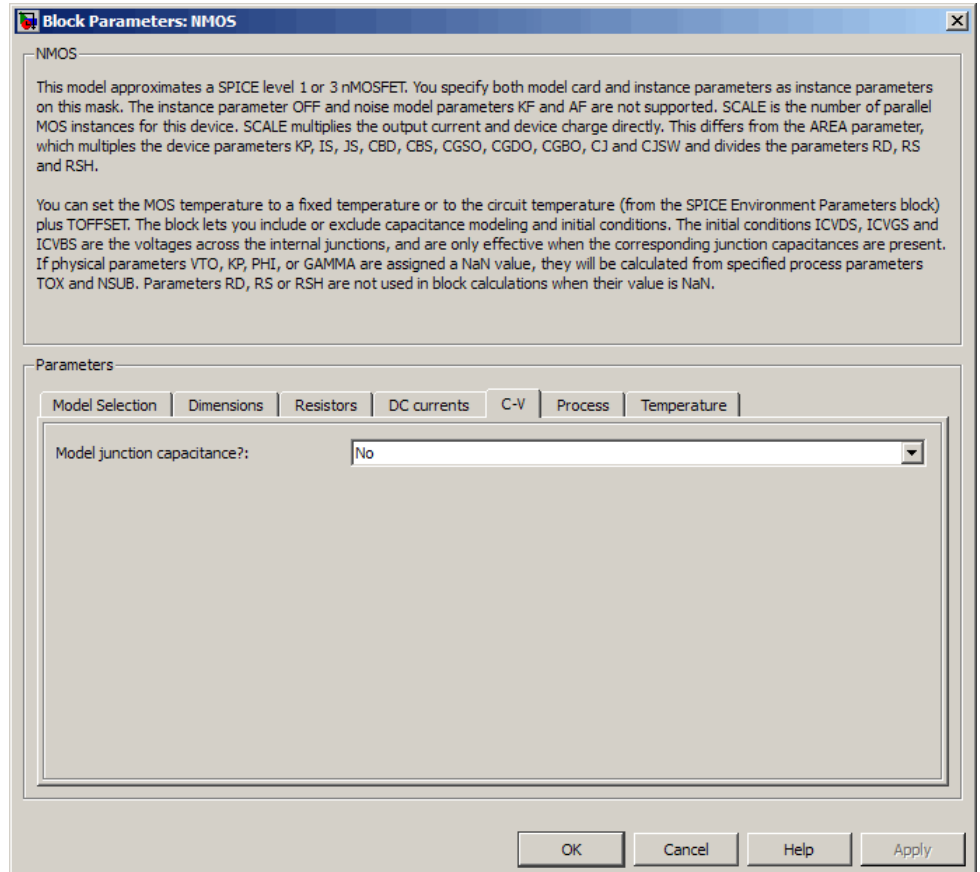

Model junction capacitance

Select one of the following options for modeling the junction capacitance:

- No — Do not include junction capacitance in the model. This is the default option.

- **Yes** — Specify zero-bias junction capacitance, junction potential, grading coefficient, forward-bias depletion and capacitance coefficient.

G-S overlap capacitance, CGSO

Gate-source capacitance due to the diffusion that occurs when the device operates in depletion mode. This parameter is only visible when you select **Yes** for the **Model junction capacitance** parameter. The default value is 0 F/m. The value must be equal to 0 or greater than or equal to Cmin. Cmin is a built-in model constant whose value is 1e-18.

G-D overlap capacitance, CGDO

Gate-drain capacitance due to the diffusion that occurs when the device operates in depletion mode. This parameter is only visible when you select **Yes** for the **Model junction capacitance** parameter. The default value is 0 F/m. The value must be equal to 0 or greater than or equal to Cmin. Cmin is a built-in model constant whose value is 1e-18.

G-B overlap capacitance, CGBO

Gate-base capacitance due to the diffusion that occurs when the device operates in depletion mode. This parameter is only visible when you select **Yes** for the **Model junction capacitance** parameter. The default value is 0 F/m. The value must be equal to 0 or greater than or equal to Cmin. Cmin is a built-in model constant whose value is 1e-18.

Zero-bias BD capacitance, CBD

The value of the capacitance placed between the base and the drain. This parameter is only visible when you select **Yes** for the **Model junction capacitance** parameter. The default value is 0 F. The value must be equal to 0 or greater than or equal to Cmin. Cmin is a built-in model constant whose value is 1e-18.

Zero-bias BS capacitance, CBS

The value of the capacitance placed between the base and the source. This parameter is only visible when you select **Yes** for the **Model junction capacitance** parameter. The default value is 0

F. The value must be equal to 0 or greater than or equal to C_{min} . C_{min} is a built-in model constant whose value is $1e-18$.

Bottom junction cap per area CJ

Zero-bias bulk junction bottom capacitance per junction area. This parameter is only visible when you select **Yes** for the **Model junction capacitance** parameter. The default value is 0 F/m^2 . The value must be equal to 0 or greater than or equal to C_{min} . C_{min} is a built-in model constant whose value is $1e-18$.

Bottom grading coefficient, MJ

The transistor bottom grading coefficient. This parameter is only visible when you select **Yes** for the **Model junction capacitance** parameter. The default value is 0.5. The value must be equal to 0 or less than MG_{max} . MG_{max} is a built-in model constant whose value is 0.9.

Side jct cap/area of jct perimeter CJSW

Zero-bias bulk junction sidewall capacitance per junction perimeter. This parameter is only visible when you select **Yes** for the **Model junction capacitance** parameter. The default value is 0 F/m . The value must be equal to 0 or greater than or equal to C_{min} . C_{min} is a built-in model constant whose value is $1e-18$.

Side grading coefficient, MJSW

The transistor sidewall grading coefficient. This parameter is only visible when you select **Yes** for the **Model junction capacitance** parameter. The default value is 0.5. The value must be equal to 0 or less than MG_{max} . MG_{max} is a built-in model constant whose value is 0.9.

Bulk junction potential, PB

The potential across the bulk junction. This parameter is only visible when you select **Yes** for the **Model junction capacitance** parameter. The default value is 0.8 V. The value must be equal to 0 or greater than or equal to VJ_{min} . VJ_{min} is a built-in model constant whose value is 0.01.

Capacitance coefficient FC

The fitting coefficient that quantifies the decrease of the depletion capacitance with applied voltage. This parameter is only visible when you select **Yes** for the **Model junction capacitance** parameter. The default value is 0.5. The value must be equal to 0 or less than or equal to FCmax. FCmax is a built-in model constant whose value is 0.95.

Specify initial condition

Select one of the following options for specifying an initial condition:

- **No** — Do not specify an initial condition for the model. This is the default option.
- **Yes** — Specify the initial diode voltage.

Note The NMOS block applies the initial diode voltage across the junction capacitors and not across the ports.

Initial condition voltage ICVDS

Drain-source voltage at the start of the simulation. This parameter is only visible when you select **Yes** for the **Model junction capacitance** and **Yes** for the **Specify initial condition** parameter. The default value is 0 V.

Initial condition voltage ICVGS

Gate-source voltage at the start of the simulation. This parameter is only visible when you select **Yes** for the **Model junction capacitance** and **Yes** for the **Specify initial condition** parameter. The default value is 0 V.

Initial condition voltage ICVBS

Bulk-source voltage at the start of the simulation. This parameter is only visible when you select **Yes** for the **Model junction capacitance** and **Yes** for the **Specify initial condition** parameter. The default value is 0 V.

Process Tab

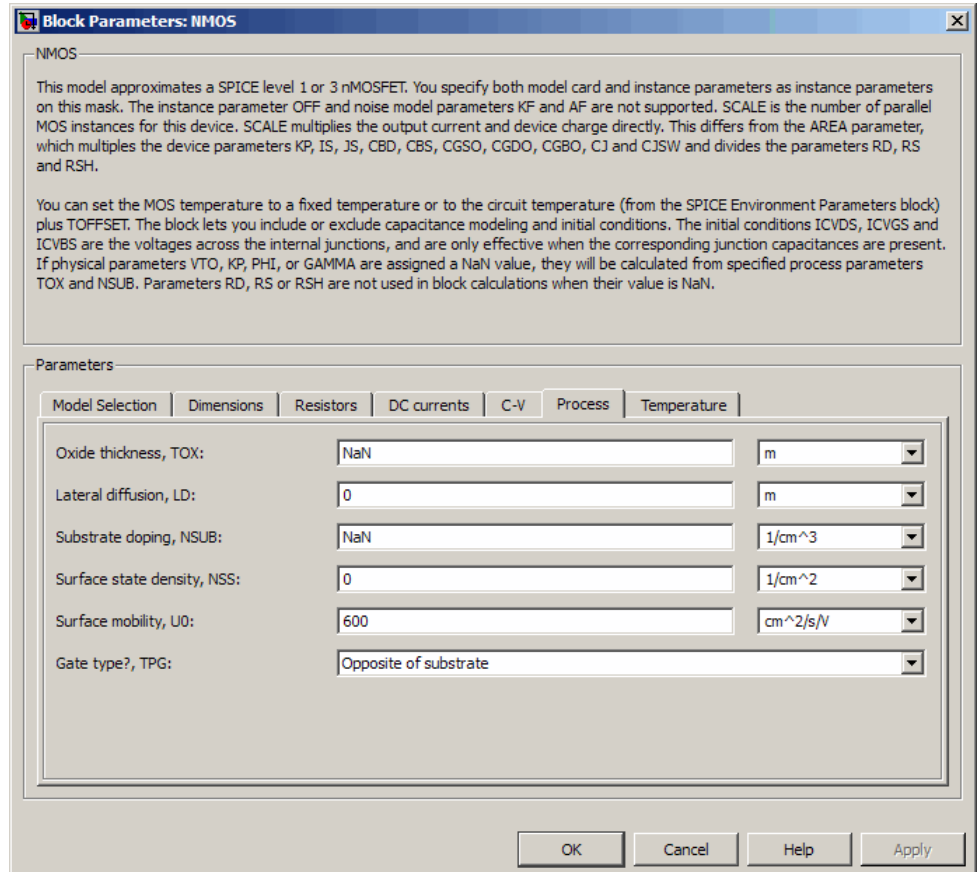

Oxide thickness, TOX

Thickness of the gate oxide. The default value is NaN m. The value must be greater than or equal to 0.

Note When you select Level 3 MOS for the **MOS model** parameter, the block uses a value of $1e-7$ rather than NaN by default.

Lateral diffusion, LD

Length of lateral diffusion. The default value is 0 m.

Substrate doping, NSUB

Substrate doping. The default value is NaN $1/\text{cm}^3$. The value must be greater than or equal to $1.45e10$ (the carrier concentration of intrinsic silicon).

Surface state density, NSS

Substrate doping. The default value is 0 $1/\text{cm}^2$.

Surface mobility, U0

Zero-bias surface mobility coefficient. The default value is 600 $\text{cm}^2/\text{V}/\text{s}$.

Junction depth, XJ

Junction depth. This parameter is only visible when you select Level 3 MOS for the **MOS model** parameter. The default value is 0 m.

Gate type?,TPG

Select one of the following MOSFET gate materials (as compared to the substrate):

- **Opposite of substrate** — The gate material is the opposite of the substrate. This means that $\text{TPG} = 1$ in the device equations. This is the default option.
- **Same as substrate** — The gate material is the same as the substrate. This means that $\text{TPG} = -1$ in the device equations.
- **Aluminum** — The gate material is aluminum. This means that $\text{TPG} = 0$ in the device equations.

Temperature Tab

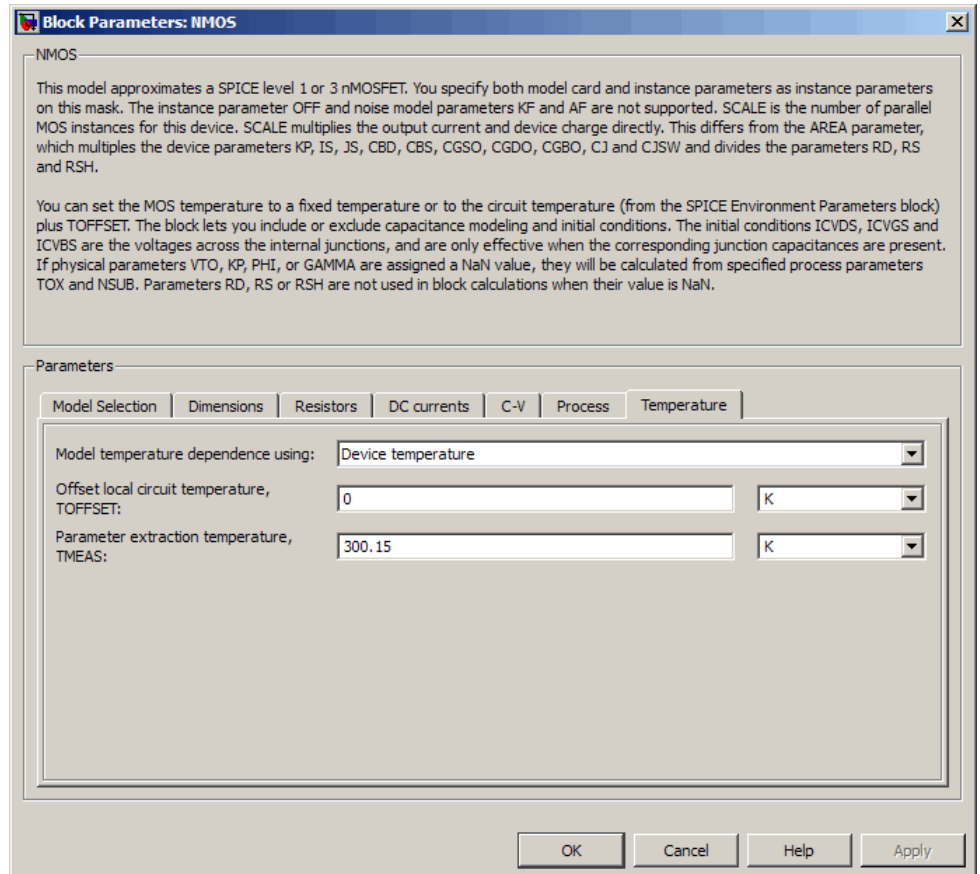

Model temperature dependence using

Select one of the following options for modeling the diode temperature dependence:

- **Device temperature** — Use the device temperature, which is the **Circuit temperature** value plus the **Offset local circuit temperature, TOFFSET** value. The **Circuit temperature**

value comes from the SPICE Environment Parameters block, if one exists in the circuit. Otherwise, it comes from the default value for this block.

- **Fixed temperature** — Use a temperature that is independent of the circuit temperature to model temperature dependence.

Offset local circuit temperature, TOFFSET

The amount by which the transistor temperature differs from the circuit temperature. This parameter is only visible when you select **Device temperature** for the **Model temperature dependence using** parameter. The default value is 0 K.

Fixed circuit temperature, TFIXED

The temperature at which to simulate the transistor. This parameter is only visible when you select **Fixed temperature** for the **Model temperature dependence using** parameter. The default value is 300.15 K. The value must be greater than 0.

Parameter extraction temperature, TMEAS

The temperature at which the transistor parameters were measured. The default value is 300.15 K. The value must be greater than 0.

Ports

The block has the following ports:

G

Electrical conserving port associated with the transistor gate terminal.

D

Electrical conserving port associated with the transistor drain terminal.

S

Electrical conserving port associated with the transistor source terminal.

NMOS

B

Electrical conserving port associated with the transistor bulk terminal.

References

[1] G. Massobrio and P. Antognetti. *Semiconductor Device Modeling with SPICE*. 2nd Edition, McGraw-Hill, 1993. Chapter 3.

See Also

PMOS

Purpose

Model Gummel-Poon NPN Transistor

Library

SPICE-Compatible Semiconductors

Description

The NPN block represents a SPICE-compatible four-terminal Gummel-Poon NPN transistor. The substrate port is connected to the transistor body using a capacitor, so these devices are equivalent to a three-terminal transistor when you connect the substrate port to any other port and use the default value of zero for the **C-S junction capacitance, CJS** parameter.

The NPN block model includes the following components:

- “Current-Voltage and Base Charge Model” on page 2-237
- “Base Resistance Model” on page 2-241
- “Transit Charge Modulation Model” on page 2-241
- “Junction Charge Model” on page 2-242
- “Temperature Dependence” on page 2-244

Current-Voltage and Base Charge Model

The current-voltage relationships and base charge relationships for the transistor are calculated adjusting the applicable model parameters for temperature as described in the following sections:

- Base-Emitter and Base-Collector Junction Currents on page 237
- Terminal Currents on page 240
- Base Charge Model on page 240

Base-Emitter and Base-Collector Junction Currents

The base-emitter junction current is calculated using the following equations:

- When $V_{BE} > 80 * V_{TF}$:

$$I_{bef} = IS * \left(\left(\frac{V_{BE}}{V_{TF}} - 79 \right) * e^{80} - 1 \right) + G_{\min} * V_{BE}$$

$$I_{bee} = ISE * \left((V_{BE} - 80 * V_{TF} + V_{TE}) * \frac{e^{(80 * V_{TF} / V_{TE})}}{V_{TE}} - 1 \right)$$

- When $V_{BE} \leq 80 * V_{TF}$

$$I_{bef} = IS * (e^{(V_{BE} / V_{TF})} - 1) + G_{\min} * V_{BE}$$

$$I_{bee} = ISE * (e^{(V_{BE} / V_{TE})} - 1)$$

The base-collector junction current is calculated using the following equations:

- When $V_{BC} > 80 * V_{TR}$:

$$I_{bcr} = IS * \left(\left(\frac{V_{BC}}{V_{TR}} - 79 \right) * e^{80} - 1 \right) + G_{\min} * V_{BC}$$

$$I_{bcc} = ISC * \left((V_{BC} - 80 * V_{TR} + V_{TC}) * \frac{e^{(80 * V_{TR} / V_{TC})}}{V_{TC}} - 1 \right)$$

- When $V_{BC} \leq 80 * V_{TR}$

$$I_{bcr} = IS * (e^{(V_{BC} / V_{TR})} - 1) + G_{\min} * V_{BC}$$

$$I_{bcc} = ISC * (e^{(V_{BC} / V_{TC})} - 1)$$

In the preceding equations:

- V_{BE} is the base-emitter voltage and V_{BC} is the base-collector voltage.

$$V_{TE} = NE * k * T / q, V_{TC} = NC * k * T / q, V_{TF} = NF * k * T / q, \text{ and}$$

- $V_{TR} = NR * k * T / q$.
- ISC and ISE are the **B-C leakage current, ISC** and **B-E leakage current, ISE** parameter values, respectively.
- NE , NC , NF , and NR are the **B-E emission coefficient, NE**, **B-C emission coefficient, NC**, **Forward emission coefficient, NF** and **Reverse emission coefficient, NR** parameter values, respectively.
- q is the elementary charge on an electron.
- k is the Boltzmann constant.
- T is the transistor temperature:
 - If you select `Device` temperature for the **Model temperature dependence using** parameter, T is the sum of the **Circuit temperature** value plus the **Offset local circuit temperature, TOFFSET** parameter value. The **Circuit temperature** value comes from the SPICE Environment Parameters block, if one exists in the circuit. Otherwise, it comes from the default value for this block.
 - If you select `Fixed` temperature for the **Model temperature dependence using** parameter, T is the **Fixed circuit temperature, TFIXED** parameter value.
- G_{min} is the minimum conductance. By default, G_{min} matches the **Minimum conductance GMIN** parameter of the SPICE Environment Parameters block, whose default value is 1e-12. To change G_{min} , add a SPICE Environment Parameters block to your model and set the **Minimum conductance GMIN** parameter to the desired value.

Terminal Currents

The terminal currents, I_B and I_C are the base and collector currents, defined as positive into the device. They are calculated as:

$$I_B = - \left(\frac{I_{ebf}}{BF} + I_{ebe} + \frac{I_{cbr}}{BR} + I_{cbc} \right)$$

$$I_C = - \left(\frac{I_{ebf} - I_{cbr}}{q_b} - \frac{I_{cbr}}{BR} - I_{cbc} \right)$$

where BF and BR are the **Forward beta, BF** and **Reverse beta, BR** parameter values, respectively.

Base Charge Model

The base charge, q_b , is calculated using the following equations:

$$q_b = \frac{q_1}{2} \left(1 + \sqrt{0.5 * \left(\sqrt{(1 + 4 * q_2 - eps)^2 + eps^2} + 1 + 4 * q_2 - eps \right) + eps} \right)$$

$$q_1 = \left(1 - \frac{V_{BC}}{VAF} - \frac{V_{BE}}{VAR} \right)^{-1}$$

$$q_2 = \frac{I_{bef}}{IKF} + \frac{I_{bcr}}{IKR}$$

where

- VAF and VAR are the **Forward Early voltage, VAF** and **Reverse Early voltage, VAR** parameters, respectively.
- IKF and IKR are the **Forward knee current, IKF** and **Reverse knee current, IKR** parameter values, respectively.
- eps is 1e-4.

Base Resistance Model

The block models base resistance in one of two ways:

- If you use the default value of infinity for the **Half base resistance cur, IRB** parameter, the NPN block calculates the base resistance r_{bb} as

$$r_{bb} = RBM + \frac{RB - RBM}{q_b}$$

where:

- RBM is the **Minimum base resistance, RBM** parameter value.
- RB is the **Zero-bias base resistance, RB** parameter value.
- If you specify a finite value for the **Half base resistance cur, IRB** parameter, the NPN block calculates the base resistance r_{bb} as

$$r_{bb} = RBM + 3 * (RB - RBM) * \left(\frac{\tan z - z}{z * \tan^2 z} \right)$$

where

$$z = \frac{\sqrt{1 + 144I_B / (\pi^2 IRB)} - 1}{(24 / \pi^2) \sqrt{(I_B / IRB)}}$$

Transit Charge Modulation Model

If you specify nonzero values for the **Coefficient of TF, XTF** parameter, the block models transit charge modulation by scaling the **Forward transit time, TF** parameter value as follows:

$$TF_{\text{mod}} = \frac{TF * \left[1 + XTF * e^{V_{BC}/(1.44V_{TF})} \left(\frac{I_{BE}}{I_{BE} + ITF} \right)^2 \right]}{q_b}$$

where ITF is the **Coefficient of TF**, ITF parameter value.

Junction Charge Model

The block lets you model junction charge. The base-collector charge Q_{bc} and the base-emitter charge Q_{be} depend on an intermediate value, Q_{dep} as follows, after adjusting the applicable model parameters for temperature:

- For the internal base-emitter junctions:

$$Q_{be} = TF_{\text{mod}} * I_{be} + Q_{dep}$$

- For the internal base-collector junctions:

$$Q_{bc} = TR * I_{bc} + XCJC * Q_{dep}$$

- For the external base-collector junctions:

$$Q_{b_{exc}} = (1 - XCJC) * Q_{dep}$$

Q_{dep} depends on the junction voltage, V_{jct} (V_{BE} for the base-emitter junction and V_{BC} for the base-collector junction) as follows.

Applicable Range of V_{jct} Values	Corresponding Q_{dep} Equation
$V_{jct} < FC * VJ$	$Q_{dep} = C_{jct} * VJ * \frac{1 - (1 - V_{jct}/VJ)^{(1-MJ)}}{1 - MJ}$
$V_{jct} \geq FC * VJ$	$Q_{dep} = C_{jct} * \left[F1 + \frac{F3 * (V_{jct} - FC * VJ) + \frac{MJ * [V_{jct}^2 - (FC * VJ)^2]}{2 * VJ}}{F2} \right]$

Where:

- FC is the **Capacitance coefficient FC** parameter value.
- VJ is:
 - The **B-E built-in potential, VJE** parameter value for the base-emitter junction.
 - The **B-C built-in potential, VJC** parameter value for the base-collector junction.
- MJ is:
 - The **B-E exponential factor, MJE** parameter value for the base-emitter junction.
 - The **B-C exponential factor, MJC** parameter value for the base-collector junction.
- C_{jct} is:
 - The **B-E depletion capacitance, CJE** parameter value for the base-emitter junction.

- The **B-C depletion capacitance, CJC** parameter value for the base-collector junction.

- $F1 = VJ * \left(1 - (1 - FC)^{(1-MJ)}\right) / (1 - MJ)$

- $F2 = (1 - FC)^{(1+MJ)}$

- $F3 = 1 - FC * (1 + MJ)$

The collector-substrate charge Q_{cs} depends on the collector-substrate voltage V_{cs} as follows, after adjusting the applicable model parameters for temperature.

Applicable Range of V_{cs} Values	Corresponding Q_{cs} Equation
$V_{cs} < 0$	$Q_{cs} = CJS * VJS * \left(\frac{1 - (1 - V_{cs}/VJS)^{(1-MJS)}}{1 - MJS} \right)$
$V_{cs} \geq 0$	$Q_{cs} = CJS * (1 + MJS * V_{cs} / (2 * VJS)) * V_{cs}$

where:

- **CJS** is the **C-S junction capacitance, CJS** parameter value.
- **VJS** is the **Substrate built-in potential, VJS** parameter value.
- **MJS** is the **Substrate exponential factor, MJS** parameter value.

Temperature Dependence

Several transistor parameters depend on temperature. There are two ways to specify the transistor temperature:

- When you select `Device` temperature for the **Model temperature dependence using** parameter, the transistor temperature is

$$T = T_C + T_O$$

where:

- T_C is the **Circuit temperature** parameter value from the SPICE Environment Parameters block. If this block doesn't exist in the circuit, T_C is the default value of this parameter.
 - T_O is the **Offset local circuit temperature, TOFFSET** parameter value.
- When you select `Fixed` temperature for the **Model temperature dependence using** parameter, the transistor temperature is the **Fixed circuit temperature, TFIXED** parameter value.

The block provides the following relationship between the saturation current IS and the transistor temperature T :

$$IS(T) = IS * (T/T_{meas})^{XTI} * e^{\left(\frac{T}{T_{meas}} - 1\right) * \frac{EG}{V_t}}$$

where:

- IS is the **Transport saturation current, IS** parameter value.
- T_{meas} is the **Parameter extraction temperature, TMEAS** parameter value.
- XTI is the **Temperature exponent for IS, XTI** parameter value.
- EG is the **Energy gap, EG** parameter value.
- $V_t = kT/q$.

The block provides the following relationship between the base-emitter junction potential V_{JE} and the transistor temperature T :

$$VJE(T) = VJE * \left(\frac{T}{T_{meas}} \right) - \frac{3 * k * T}{q} * \log \left(\frac{T}{T_{meas}} \right) - \left(\frac{T}{T_{meas}} \right) * EG_{T_{meas}} + EG_T$$

where:

- VJE is the **B-E built-in potential**, **VJE** parameter value.
- $EG_{T_{meas}} = 1.16eV - (7.02e - 4 * T_{meas}^2) / (T_{meas} + 1108)$
- $EG_T = 1.16eV - (7.02e - 4 * T^2) / (T + 1108)$

The block uses the $VJE(T)$ equation to calculate the base-collector junction potential by substituting VJC (the **B-C built-in potential**, **VJC** parameter value) for VJE .

The block provides the following relationship between the base-emitter junction capacitance CJE and the transistor temperature T :

$$CJE(T) = CJE * \left[1 + MJE * \left(400e - 6 * (T - T_{meas}) - \frac{VJE(T) - VJE}{VJE} \right) \right]$$

where:

- CJE is the **B-E depletion capacitance**, **CJE** parameter value.
- MJE is the **B-E exponential factor**, **MJE** parameter value.

The block uses the $CJE(T)$ equation to calculate the base-collector junction capacitance by substituting CJC (the **B-C depletion capacitance**, **CJC** parameter value) for CJE and MJC (the **B-C exponential factor**, **MJC** parameter value) for MJE .

The block provides the following relationship between the forward and reverse beta and the transistor temperature T :

$$\beta(T) = \beta * \left(\frac{T}{T_{meas}} \right)^{XTB}$$

where:

- β is the **Forward beta, BF** or **Reverse beta, BR** parameter value.
- XTB is the **Beta temperature exponent, XTB** parameter value.

The block provides the following relationship between the base-emitter leakage current ISE and the transistor temperature T :

$$ISE(T) = ISE * \left(\frac{T}{T_{meas}} \right)^{-XTB} * \left(\frac{IS(T)}{IS} \right)^{1/NE}$$

where:

- ISE is the **B-E leakage current, ISE** parameter value.
- NE is the **B-E emission coefficient, NE** parameter value.

The block uses this equation to calculate the base-collector leakage current by substituting ISC (the **B-C leakage current, ISC** parameter value) for ISE and NC (the **B-C emission coefficient, NC** parameter value) for NE .

Basic Assumptions and Limitations

The model is based on the following assumptions:

- The NPN block does not support noise analysis.
- The NPN block applies initial conditions across junction capacitors and not across the block ports.

Dialog Box and Parameters

Main Tab

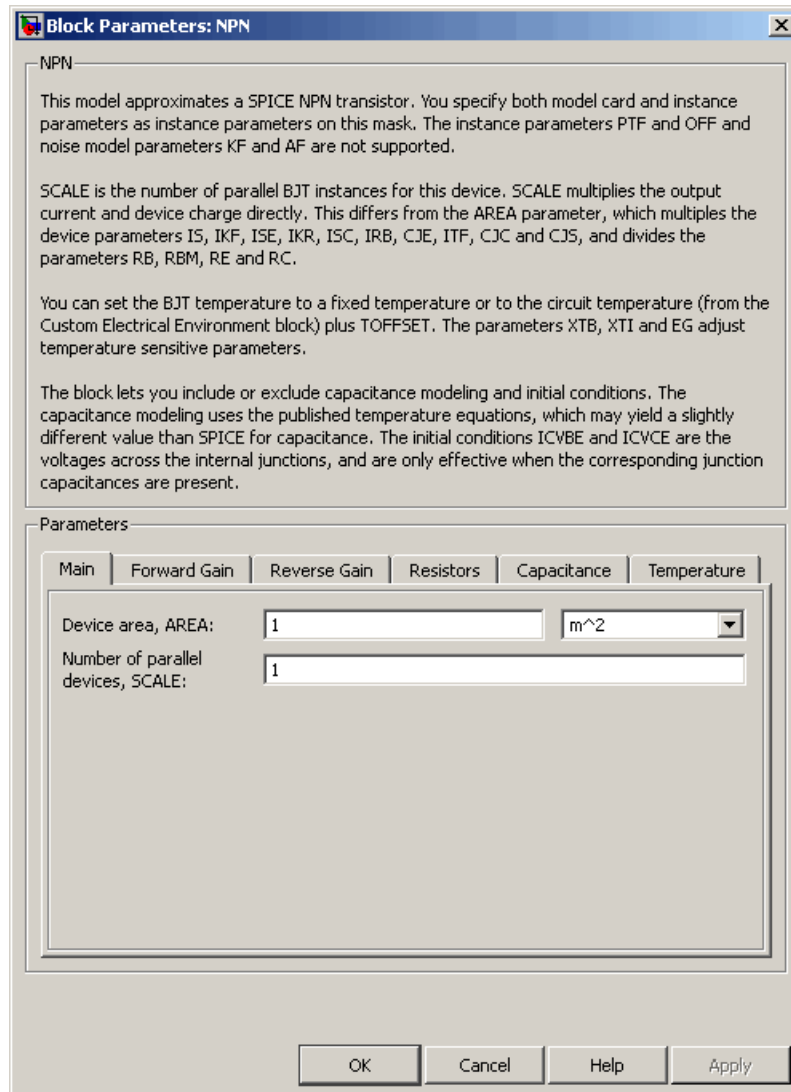

Device area, AREA

The transistor area. This value multiplies the following parameter values:

- **Transport saturation current, IS**
- **Forward knee current, IKF**
- **B-E leakage current, ISE**
- **Reverse knee current, IKR**
- **B-C leakage current, ISC**
- **Half base resistance cur, IRB**
- **B-E depletion capacitance, CJE**
- **Coefficient of TF, ITF**
- **B-C depletion capacitance, CJC**
- **C-S junction capacitance, CJS**

It divides the following parameter values:

- **Zero-bias base resistance, RB**
- **Minimum base resistance, RBM**
- **Emitter resistance, RE**
- **Collector resistance, RC**

The default value is 1 m². The value must be greater than 0.

Number of parallel devices, SCALE

The number of parallel transistors the block represents. This value multiplies the output current and device charges. The default value is 1. The value must be greater than 0.

Forward Gain Tab

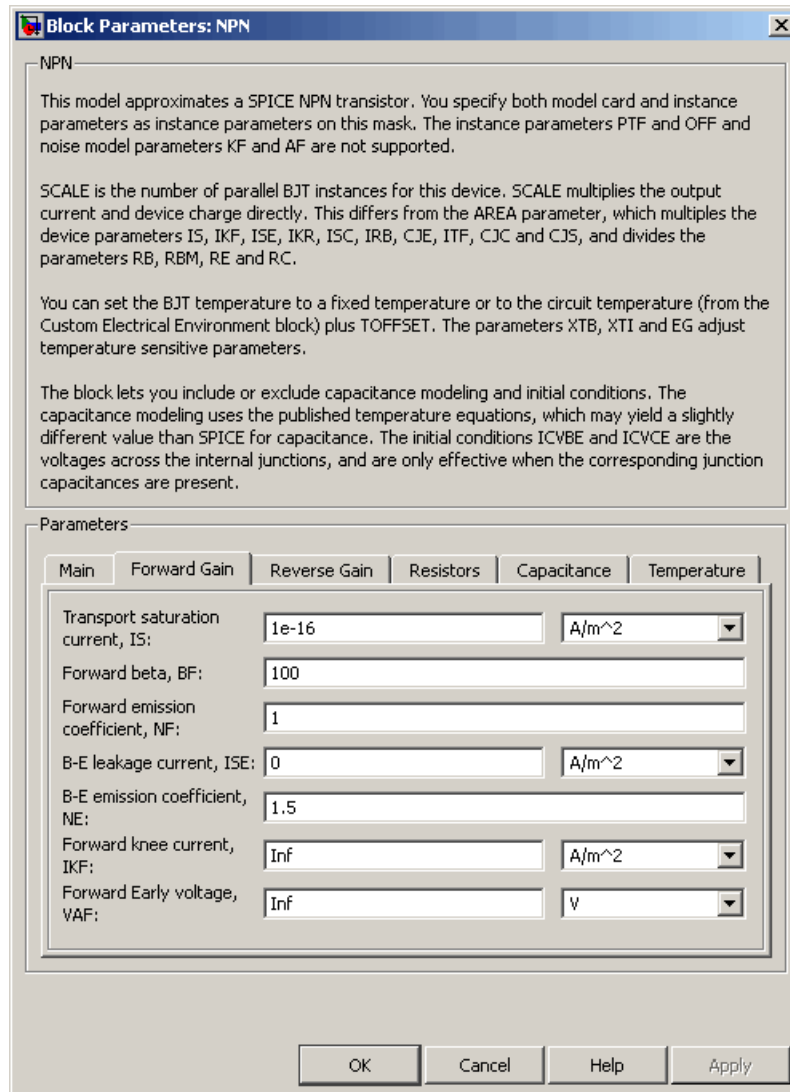

Transport saturation current, IS

The magnitude of the current at which the transistor saturates. The default value is $1e-16$ A/m². The value must be greater than or equal to 0.

Forward beta, BF

The ideal maximum reverse beta. The default value is 100. The value must be greater than 0.

Forward emission coefficient, NF

The reverse emission coefficient or ideality factor. The default value is 1. The value must be greater than 0.

B-E leakage current, ISE

The base-emitter leakage current. The default value is 0 A/m². The value must be greater than or equal to 0.

B-E emission coefficient, NE

The base-collector emission coefficient or ideality factor. The default value is 1.5. The value must be greater than 0.

Forward knee current, IKF

The current value at which forward-beta high-current roll-off occurs. The default value is Inf A/m². The value must be greater than or equal to 0.

Forward Early voltage, VAF

The forward Early voltage. The default value is Inf V. The value must be greater than or equal to 0.

Reverse Gain Tab

Block Parameters: NPN
X

NPN

This model approximates a SPICE NPN transistor. You specify both model card and instance parameters as instance parameters on this mask. The instance parameters PTF and OFF and noise model parameters KF and AF are not supported.

SCALE is the number of parallel BJT instances for this device. SCALE multiplies the output current and device charge directly. This differs from the AREA parameter, which multiplies the device parameters IS, IKF, ISE, IKR, ISC, IRB, CJE, ITF, CJC and CJS, and divides the parameters RB, RBM, RE and RC.

You can set the BJT temperature to a fixed temperature or to the circuit temperature (from the Custom Electrical Environment block) plus TOFFSET. The parameters XTB, XTI and EG adjust temperature sensitive parameters.

The block lets you include or exclude capacitance modeling and initial conditions. The capacitance modeling uses the published temperature equations, which may yield a slightly different value than SPICE for capacitance. The initial conditions ICVBE and ICVCE are the voltages across the internal junctions, and are only effective when the corresponding junction capacitances are present.

Parameters

Main	Forward Gain	Reverse Gain	Resistors	Capacitance	Temperature																																				
<div style="border: 1px solid gray; padding: 5px;"> <table style="width: 100%; border-collapse: collapse;"> <tr> <td style="width: 30%;">Reverse beta, BR:</td> <td style="width: 30%;"><input type="text" value="1"/></td> <td style="width: 30%;"></td> <td style="width: 10%;"></td> <td style="width: 10%;"></td> <td style="width: 10%;"></td> </tr> <tr> <td>Reverse emission coefficient, NR:</td> <td><input type="text" value="1"/></td> <td></td> <td></td> <td></td> <td></td> </tr> <tr> <td>B-C leakage current, ISC:</td> <td><input type="text" value="0"/></td> <td></td> <td></td> <td><input type="text" value="A/m^2"/></td> <td><input type="text"/></td> </tr> <tr> <td>B-C emission coefficient, NC:</td> <td><input type="text" value="2"/></td> <td></td> <td></td> <td></td> <td></td> </tr> <tr> <td>Reverse knee current, IKR:</td> <td><input type="text" value="Inf"/></td> <td></td> <td></td> <td><input type="text" value="A/m^2"/></td> <td><input type="text"/></td> </tr> <tr> <td>Reverse Early voltage, VAR:</td> <td><input type="text" value="Inf"/></td> <td></td> <td></td> <td><input type="text" value="V"/></td> <td><input type="text"/></td> </tr> </table> </div>						Reverse beta, BR:	<input type="text" value="1"/>					Reverse emission coefficient, NR:	<input type="text" value="1"/>					B-C leakage current, ISC:	<input type="text" value="0"/>			<input type="text" value="A/m^2"/>	<input type="text"/>	B-C emission coefficient, NC:	<input type="text" value="2"/>					Reverse knee current, IKR:	<input type="text" value="Inf"/>			<input type="text" value="A/m^2"/>	<input type="text"/>	Reverse Early voltage, VAR:	<input type="text" value="Inf"/>			<input type="text" value="V"/>	<input type="text"/>
Reverse beta, BR:	<input type="text" value="1"/>																																								
Reverse emission coefficient, NR:	<input type="text" value="1"/>																																								
B-C leakage current, ISC:	<input type="text" value="0"/>			<input type="text" value="A/m^2"/>	<input type="text"/>																																				
B-C emission coefficient, NC:	<input type="text" value="2"/>																																								
Reverse knee current, IKR:	<input type="text" value="Inf"/>			<input type="text" value="A/m^2"/>	<input type="text"/>																																				
Reverse Early voltage, VAR:	<input type="text" value="Inf"/>			<input type="text" value="V"/>	<input type="text"/>																																				

Reverse beta, BR

The ideal maximum reverse beta. The default value is 1. The value must be greater than 0.

Reverse emission coefficient, NR

The reverse emission coefficient or ideality factor. The default value is 1. The value must be greater than 0.

B-C leakage current, ISC

The base-collector leakage current. The default value is 0 A/m². The value must be greater than or equal to 0.

B-C emission coefficient, NC

The base-collector emission coefficient or ideality factor. The default value is 2. The value must be greater than 0.

Reverse knee current, IKR

The current value at which reverse-beta high-current roll-off occurs. The default value is Inf A/m². The value must be greater than or equal to 0.

Reverse Early voltage, VAR

The reverse Early voltage. The default value is Inf V. The value must be greater than or equal to 0.

Resistors Tab

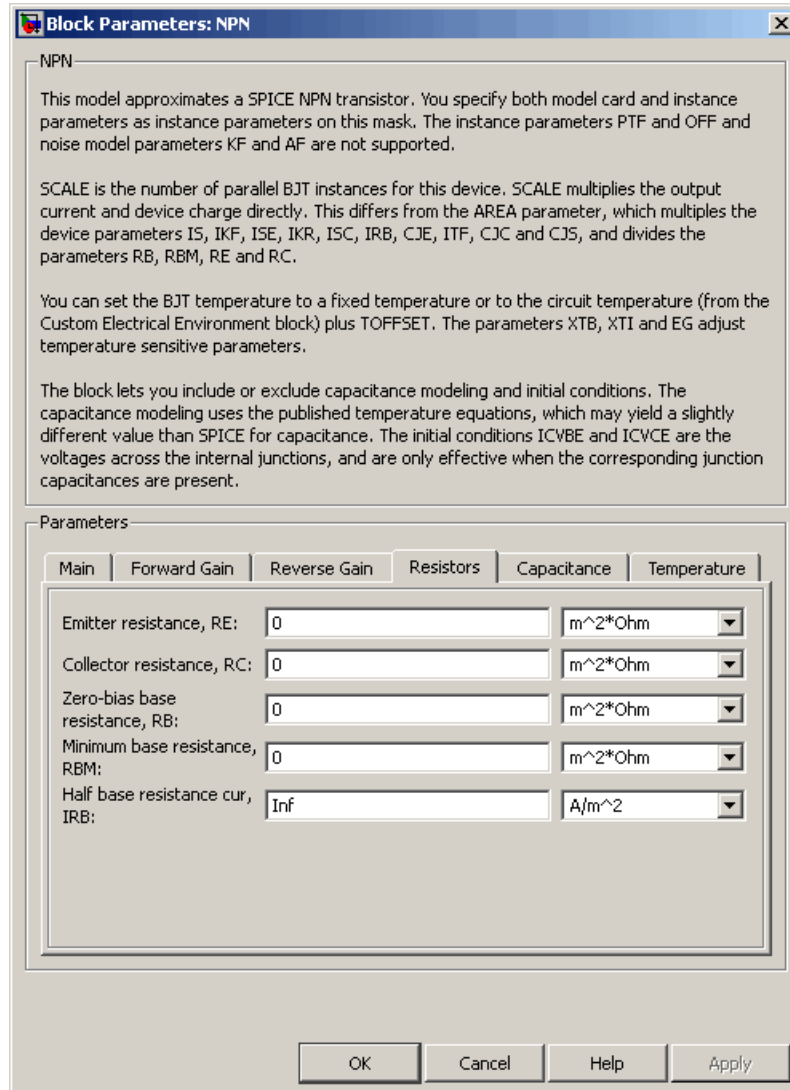

Emitter resistance, RE

The resistance of the emitter. The default value is $0 \text{ m}^2 \cdot \Omega$. The value must be greater than or equal to 0.

Collector resistance, RC

The resistance of the collector. The default value is $0 \text{ m}^2 \cdot \Omega$. The value must be greater than or equal to 0.

Zero-bias base resistance, RB

The resistance of the collector. The default value is $0 \text{ m}^2 \cdot \Omega$. The value must be greater than or equal to 0.

Minimum base resistance, RBM

The resistance of the collector. The default value is $0 \text{ m}^2 \cdot \Omega$. The value must be less than or equal to the **Zero-bias base resistance, RB** parameter value.

Half base resistance cur, IRB

The base current at which the base resistance has dropped to half of its zero-bias value. The default value is Inf A/m^2 . The value must be greater than or equal to 0. Use the default value of Inf if you do not want to model the change in base resistance as a function of base current.

Capacitance Tab

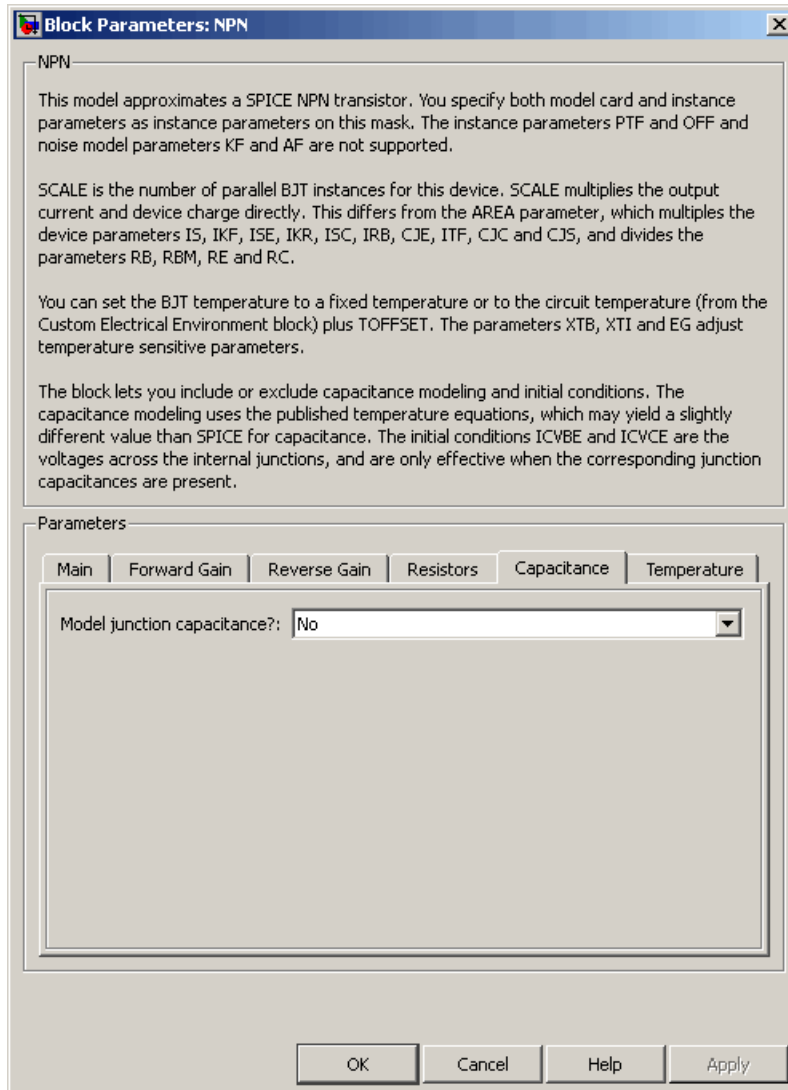

Model junction capacitance

Select one of the following options for modeling the junction capacitance:

- **No** — Do not include junction capacitance in the model. This is the default option.
- **B-E Capacitance** — Model the junction capacitance across the base-emitter junction.
- **B-C Capacitance** — Model the junction capacitance across the base-collector junction.
- **C-S Capacitance** — Model the junction capacitance across the collector-substrate junction.

Note To include junction capacitance in the model:

- 1** Select **B-E Capacitance** and specify the base-emitter junction capacitance parameters.
- 2** Select **B-C Capacitance** and specify the base-collector junction capacitance parameters.
- 3** Select **C-S Capacitance** and specify the collector-substrate junction capacitance parameters.

You can specify or change any of the common parameters when you select any of the preceding options for the **Model junction capacitance** parameter.

B-E depletion capacitance, CJE

The depletion capacitance across the base-emitter junction. This parameter is only visible when you select **B-E Capacitance** for the **Model junction capacitance** parameter. The default value is 0 F/m². The value must be greater than or equal to 0.

B-E built-in potential, VJE

The base-emitter junction potential. This parameter is only visible when you select B-E Capacitance for the **Model junction capacitance** parameter. The default value is 0.75 V. The value must be greater than or equal to 0.01 V.

B-E exponential factor, MJE

The grading coefficient for the base-emitter junction. This parameter is only visible when you select B-E Capacitance for the **Model junction capacitance** parameter. The default value is 0.33. The value must be greater than or equal to 0 and less than or equal to 0.9.

Forward transit time, TF

The transit time of the minority carriers that cause diffusion capacitance when the base-emitter junction is forward-biased. This parameter is only visible when you select B-E Capacitance for the **Model junction capacitance** parameter. The default value is 0. The value must be greater than or equal to 0.

Coefficient of TF, XTF

The coefficient for the base-emitter and base-collector bias dependence of the transit time, which produces a charge across the base-emitter junction. This parameter is only visible when you select B-E Capacitance for the **Model junction capacitance** parameter. The default value is 0. The value must be greater than or equal to 0. Use the default value of 0 if you do not want to model the effect of base-emitter bias on transit time.

VBC dependence of TF, VTF

The coefficient for the base-emitter bias dependence of the transit time. This parameter is only visible when you select B-E Capacitance for the **Model junction capacitance** parameter. The default value is Inf V. The value must be greater than or equal to 0.

Coefficient of TF, ITF

The coefficient for the dependence of the transit time on collector current. This parameter is only visible when you select B-E

Capacitance for the **Model junction capacitance** parameter. The default value is 0 A/m². The value must be greater than or equal to 0. Use the default value of 0 if you do not want to model the effect of collector current on transit time.

B-C depletion capacitance, CJC

The depletion capacitance across the base-collector junction. This parameter is only visible when you select **B-C Capacitance** for the **Model junction capacitance** parameter. The default value is 0 F/m². The value must be greater than 0.

B-C built-in potential, VJC

The base-collector junction potential. This parameter is only visible when you select **B-C Capacitance** for the **Model junction capacitance** parameter. The default value is 0.75 V. The value must be greater than or equal to 0.01 V.

B-C exponential factor, MJC

The grading coefficient for the base-collector junction. This parameter is only visible when you select **B-C Capacitance** for the **Model junction capacitance** parameter. The default value is 0.33. The value must be greater than or equal to 0 and less than or equal to 0.9.

B-C capacitance fraction, XCJC

The fraction of the base-collector depletion capacitance that is connected between the internal base and the internal collector. The rest of the base-collector depletion capacitance is connected between the external base and the internal collector. This parameter is only visible when you select **B-C Capacitance** for the **Model junction capacitance** parameter. The default value is 0. The value must be greater than or equal to 0 and less than or equal to 1.

Reverse transit time, TR

The transit time of the minority carriers that cause diffusion capacitance when the base-collector junction is reverse-biased. This parameter is only visible when you select **B-C Capacitance**

for the **Model junction capacitance** parameter. The default value is 0 s. The value must be greater than or equal to 0.

Capacitance coefficient FC

The fitting coefficient that quantifies the decrease of the depletion capacitance with applied voltage. This parameter is only visible when you select B-E Capacitance or B-C Capacitance for the **Model junction capacitance** parameter. The default value is 0.5. The value must be greater than or equal to 0 and less than or equal to 0.95.

Specify initial condition

Select one of the following options for specifying an initial condition:

- No — Do not specify an initial condition for the model. This is the default option.
- Yes — Specify the initial transistor conditions.

Note The NPN block applies the initial transistor voltages across the junction capacitors and not across the ports.

This parameter is only visible when you select B-E Capacitance or B-C Capacitance for the **Model junction capacitance** parameter.

Initial condition voltage ICVBE

Base-emitter voltage at the start of the simulation. This parameter is only visible when you select B-E Capacitance or B-C Capacitance for the **Model junction capacitance** and Yes for the **Specify initial condition** parameter. The default value is 0 V.

Initial condition voltage ICVCE

Base-collector voltage at the start of the simulation. This parameter is only visible when you select B-E Capacitance or B-C Capacitance for the **Model junction capacitance** and Yes

for the **Specify initial condition** parameter. The default value is 0 V.

C-S junction capacitance, CJS

The collector-substrate junction capacitance. This parameter is only visible when you select **C-S Capacitance** for the **Model junction capacitance** parameter. The default value is 0 F/m². The value must be greater than or equal to 0.

Substrate built-in potential, VJS

The potential of the substrate. This parameter is only visible when you select **C-S Capacitance** for the **Model junction capacitance** parameter. The default value is 0.75 V.

Substrate exponential factor, MJS

The grading coefficient for the collector-substrate junction. This parameter is only visible when you select **C-S Capacitance** for the **Model junction capacitance** parameter. The default value is 0. The value must be greater than or equal to 0 and less than or equal to 0.9.

Temperature Tab

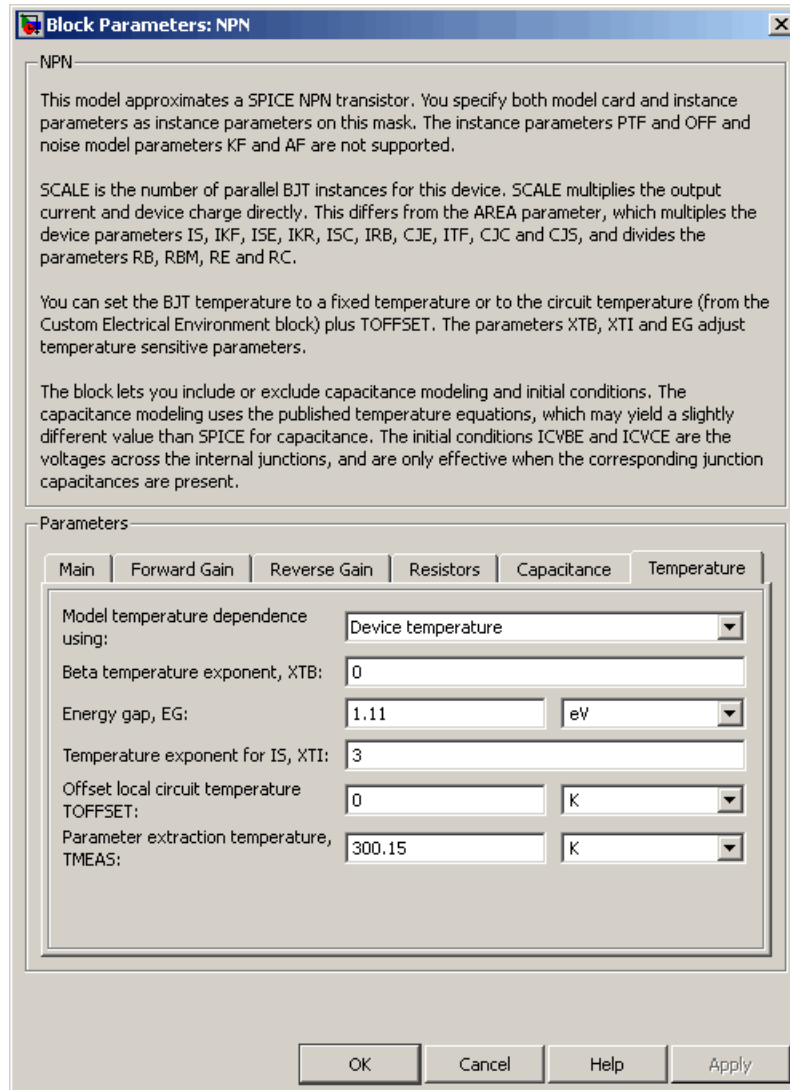

Model temperature dependence using

Select one of the following options for modeling the transistor temperature dependence:

- **Device temperature** — Use the device temperature, which is the **Circuit temperature** value plus the **Offset local circuit temperature, TOFFSET** value. The **Circuit temperature** value comes from the SPICE Environment Parameters block, if one exists in the circuit. Otherwise, it comes from the default value for this block.
- **Fixed temperature** — Use a temperature that is independent of the circuit temperature to model temperature dependence.

Beta temperature exponent, XTB

The forward and reverse beta temperature exponent that models base current temperature dependence. This parameter is only visible when you select **Device temperature** for the **Model temperature dependence using** parameter. The default value is 0. The value must be greater than or equal to 0.

Energy gap, EG

The energy gap that affects the increase in the saturation current as temperature increases. This parameter is only visible when you select **Device temperature** for the **Model temperature dependence using** parameter. The default value is 1.11 eV. The value must be greater than or equal to 0.1.

Temperature exponent for IS, XTI

The order of the exponential increase in the saturation current as temperature increases. This parameter is only visible when you select **Device temperature** for the **Model temperature dependence using** parameter. The default value is 3. The value must be greater than or equal to 0.

Offset local circuit temperature, TOFFSET

The amount by which the transistor temperature differs from the circuit temperature. This parameter is only visible when you select **Device temperature** for the **Model temperature dependence using** parameter. The default value is 0 K.

Parameter extraction temperature, TMEAS

The temperature at which the transistor parameters were measured. The default value is 300.15 K. The value must be greater than 0.

Fixed circuit temperature, TFIXED

The temperature at which to simulate the transistor. This parameter is only visible when you select `Fixed temperature` for the **Model temperature dependence using** parameter. The default value is 300.15 K. The value must be greater than 0.

Ports

The block has the following ports:

B

Electrical conserving port associated with the transistor base terminal.

C

Electrical conserving port associated with the transistor collector terminal.

E

Electrical conserving port associated with the transistor emitter terminal.

S

Electrical conserving port associated with the transistor substrate terminal.

Examples

See the `Creating a SPICE-Compatible Circuit with the Extended Electrical Library` demo.

References

[1] G. Massobrio and P. Antognetti. *Semiconductor Device Modeling with SPICE*. 2nd Edition, McGraw-Hill, 1993. Chapter 2.

See Also

NPN Bipolar Transistor

Purpose Model NPN bipolar transistor using enhanced Ebers-Moll equations

Library Semiconductor Devices

Description



NPN Bipolar Transistor

The NPN Bipolar Transistor block uses a variant of the Ebers-Moll equations to represent an NPN bipolar transistor. The Ebers-Moll equations are based on two exponential diodes plus two current-controlled current sources. The NPN Bipolar Transistor block provides the following enhancements to that model:

- Early voltage effect
- Optional base, collector, and emitter resistances.
- Optional fixed base-emitter and base-collector capacitances.

The collector and base currents are:

$$I_C = I_S \left[\left(e^{qV_{BE}/(kT)} - e^{qV_{BC}/(kT)} \right) \left(1 - \frac{V_{BC}}{V_A} \right) - \frac{1}{\beta_R} \left(e^{qV_{BC}/(kT)} - 1 \right) \right]$$

$$I_B = I_S \left[\frac{1}{\beta_F} \left(e^{qV_{BE}/(kT)} - 1 \right) + \frac{1}{\beta_R} \left(e^{qV_{BC}/(kT)} - 1 \right) \right]$$

Where:

- I_B and I_C are base and collector currents, defined as positive into the device.
- V_{be} is the base-emitter voltage and V_{bc} is the base-collector voltage.
- β_F is the ideal maximum current gain BF
- β_R is the ideal maximum current gain BR
- V_A is the forward Early voltage VAF
- q is the elementary charge on an electron (1.602176e-19 Coulombs).
- k is the Boltzmann constant (1.3806503e-23 J/K).

NPN Bipolar Transistor

- T is the transistor temperature, as defined by the **Measurement temperature** parameter value.

You can specify the transistor behavior using datasheet parameters that the block uses to calculate the parameters for these equations, or you can specify the equation parameters directly.

If $qV_{BC}/(kT) > 40$ or $qV_{BE}/(kT) > 40$, the corresponding exponential terms in the equations are replaced with $(qV_{BC}/(kT) - 39)e^{40}$ and $(qV_{BE}/(kT) - 39)e^{40}$, respectively. This helps prevent numerical issues associated with the steep gradient of the exponential function e^x at large values of x . Similarly, if $qV_{BC}/(kT) < -39$ or $qV_{BE}/(kT) < -39$ then the corresponding exponential terms in the equations are replaced with $(qV_{BC}/(kT) + 40)e^{-39}$ and $(qV_{BE}/(kT) + 40)e^{-39}$, respectively.

Optionally, you can specify parasitic fixed capacitances across the base-emitter and base-collector junctions. You also have the option to specify base, collector, and emitter connection resistances.

Basic Assumptions and Limitations

The NPN Bipolar Transistor model has the following limitations:

- This block does not model temperature-dependent effects. SimElectronics simulates the block at the temperature at which the component behavior was measured, as specified by the **Measurement temperature** parameter value.
- You may need to use nonzero ohmic resistance and junction capacitance values to prevent numerical simulation issues, but the simulation may run faster with these values set to zero.

Dialog Box and Parameters

Main Tab

Block Parameters: NPN Bipolar Transistor

NPN Bipolar Transistor

This block represents an NPN transistor modeled using a variant of the Ebers-Moll equations. The Ebers-Moll equations are based on two exponential diodes plus two current-controlled current sources. In addition, this block adds the Early voltage effect, and gives the option to include base, emitter and emitter resistances plus fixed base-emitter and base-collector capacitances. For full details of the equations, consult the documentation. The equation parameters can either be specified directly, or are derived from standard datasheet parameters.

Parameters

Main | Ohmic Resistance | Junction Capacitance

Parameterization: Specify from a datasheet

Forward current transfer ratio h_{fe} : 100

Output admittance h_{oe} : 5e-05 1/Ohm

Collector current at which h-parameters are defined: 1 mA

Voltage V_{be} : 0.55 V

Current I_b for voltage V_{be} : 0.5 mA

Reverse current transfer ratio BR: 1

Measurement temperature: 25 C

OK Cancel Help Apply

Parameterization

Select one of the following methods for block parameterization:

- **Specify from a datasheet** — Provide parameters that the block converts to equations that describe the transistor. The block calculates the forward Early voltage VAF as I_c/h_{oe} , where I_c is the **Collector current at which h-parameters are defined** parameter value, and h_{oe} is the **Output**

NPN Bipolar Transistor

admittance h_{oe} parameter value [2]. The block sets BF to the small-signal **Forward current transfer ratio h_{fe}** value. The block calculates the saturation current IS from the specified **Voltage V_{be}** value and the corresponding **Current I_b for voltage V_{be}** value when I_c is zero. This is the default method.

- Specify using equation parameters directly — Provide equation parameters IS , BF , and VA_F .

Forward current transfer ratio h_{fe}

Small-signal current gain. This parameter is only visible when you select **Specify** from a datasheet for the **Parameterization** parameter. The default value is 100.

Output admittance h_{oe}

Derivative of the collector current with respect to the collector-emitter voltage for a fixed base current. This parameter is only visible when you select **Specify** from a datasheet for the **Parameterization** parameter. The default value is $5e-05$ $1/\Omega$.

Collector current at which h-parameters are defined

The h-parameters vary with operating point, and are defined for this value of the collector current. This parameter is only visible when you select **Specify** from a datasheet for the **Parameterization** parameter. The default value is 1 mA.

Voltage V_{be}

Base-emitter voltage when the collector current is zero and the base current is I_b . This parameter is only visible when you select **Specify** from a datasheet for the **Parameterization** parameter. The default value is 0.55 V.

Current I_b for voltage V_{be}

Base current when the base-emitter voltage is V_{be} and the collector current is zero. This parameter is only visible when you select **Specify** from a datasheet for the **Parameterization** parameter. The default value is 0.5 mA.

Forward current transfer ratio BF

Ideal maximum forward current gain. This parameter is only visible when you select **Specify using equation parameters** directly for the **Parameterization** parameter. The default value is 100.

Saturation current IS

Transistor saturation current. This parameter is only visible when you select **Specify using equation parameters** directly for the **Parameterization** parameter. The default value is $1e-14$ A.

Forward Early voltage VAF

In the standard Ebers-Moll equations, the gradient of the I_c versus V_{ce} curve is zero in the normal active region. The additional forward Early voltage term increases this gradient. The intercept on the V_{ce} -axis is equal to $-V_{AF}$ when the linear region is extrapolated. This parameter is only visible when you select **Specify using equation parameters** directly for the **Parameterization** parameter. The default value is 200 V.

Reverse current transfer ratio BR

Ideal maximum reverse current gain. This value is often not quoted in manufacturer datasheets, because it is not significant when the transistor is biased to operate in the normal active region. When the value is not known and the transistor is not to be operated on the inverse region, use the default value of 1.

Measurement temperature

Temperature at which V_{be} and I_b or I_S are measured. This parameter is only visible when you select **Specify from a datasheet** for the **Parameterization** parameter. The default value is 25 °C.

NPN Bipolar Transistor

Ohmic Resistance Tab

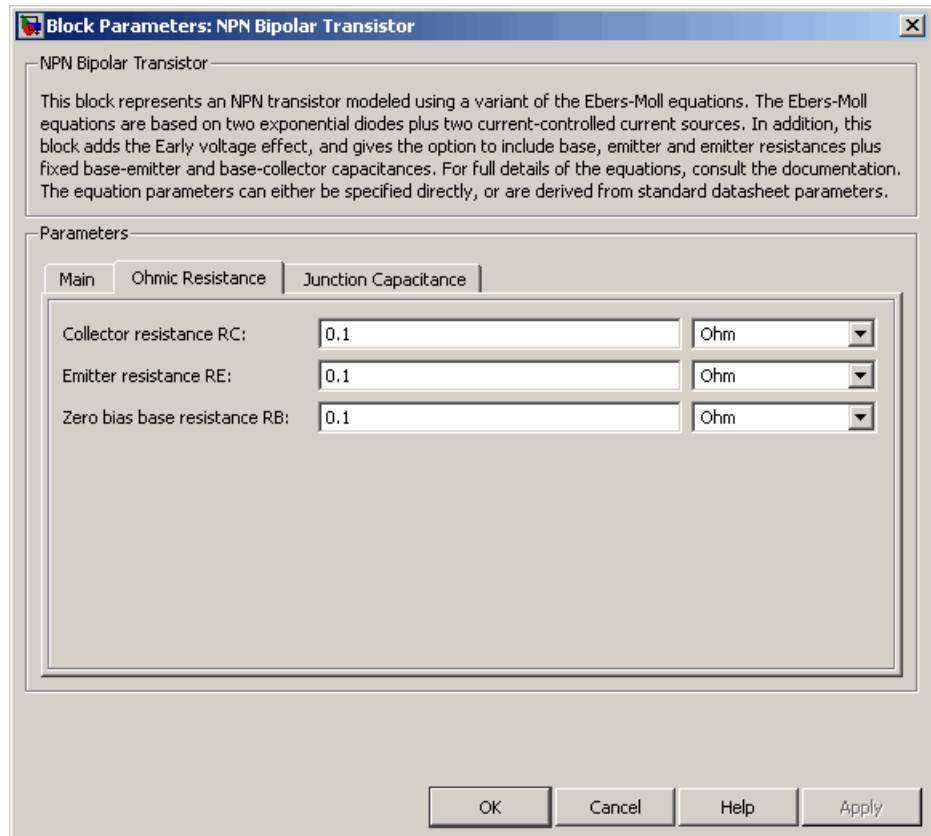

Collector resistance RC

Resistance at the collector. The default value is 0.1 Ω .

Emitter resistance RE

Resistance at the emitter. The default value is 0.1 Ω .

Zero bias base resistance RB

Resistance at the base at zero bias. The default value is 0.1 Ω .

Junction Capacitance Tab

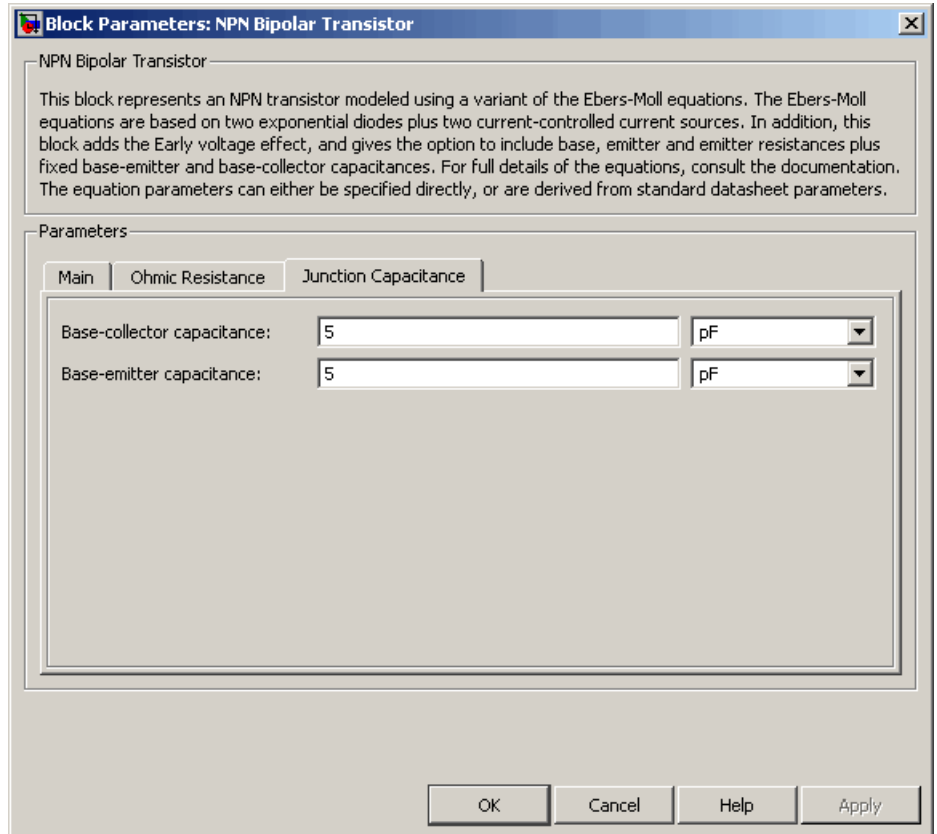

Base-collector capacitance

Parasitic capacitance across the base-collector junction. The default value is 5 pF.

Base-emitter capacitance

Parasitic capacitance across the base-emitter junction. The default value is 5 pF.

NPN Bipolar Transistor

Ports

The block has the following ports:

B

Electrical conserving port associated with the transistor base terminal.

C

Electrical conserving port associated with the transistor collector terminal.

E

Electrical conserving port associated with the transistor emitter terminal.

Examples

See the Bipolar Transistor Characteristics demo.

References

[1] G. Massobrio and P. Antognetti. *Semiconductor Device Modeling with SPICE*. 2nd Edition, McGraw-Hill, 1993.

[2] H. Ahmed and P.J. Spreadbury. *Analogue and digital electronics for engineers*. 2nd Edition, Cambridge University Press, 1984.

See Also

Diode, PNP Bipolar Transistor

Purpose Model optocoupler as LED, current sensor, and controlled current source

Library Semiconductor Devices

Description This block represents an optocoupler using a model that consists of the following components:

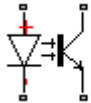

Optocoupler

- An exponential light-emitting diode in series with a current sensor on the input side
- A controlled current source on the output side

The output-side current flows from the collector junction to the emitter junction. It has a value of $CTR * I_d$, where **CTR** is the **Current transfer ratio** parameter value and I_d is the diode current.

Use the Optocoupler block to interface two electrical circuits without making a direct electrical connection. A common reason for doing this is that the two circuits work at very different voltage levels.

Note Each electrical circuit must have its own Electrical Reference block.

If the output circuit is a phototransistor, typical values for the **Current transfer ratio** parameter are 0.1 to 0.5. If the output stage consists of a Darlington pair, the parameter value can be much higher than this. The **Current transfer ratio** value also varies with the light-emitting diode current, but this effect is not modeled by the Photodiode block.

Some manufacturers provide a maximum data rate for optocouplers. In practice, the maximum data rate depends on the following factors:

- The capacitance of the photodiode and the type of the driving circuit
- The construction of the phototransistor and its associated capacitance

Optocoupler

The Optocoupler block only lets you define the capacitance on the light-emitting diode. You can use the **Junction capacitance** parameter to add your own capacitance across the collector and emitter connections.

Basic Assumptions and Limitations

The Optocoupler block has the following limitations:

- The output side is modeled as a controlled current source. As such, it only correctly approximates a bipolar transistor operating in its normal active region. To create a more detailed model, connect the Optocoupler output directly to the base of an NPN Bipolar Transistor block, and set the parameters to maintain a correct overall value for the current transfer ratio. If you need to connect optocouplers in series, use this approach to avoid the invalid topology of two current sources in series.
- This block does not model temperature-dependent effects. SimElectronics simulates the block at the temperature at which the component behavior was measured, as specified by the **Measurement temperature** parameter value.
- You may need to use nonzero ohmic resistance and junction capacitance values to prevent numerical simulation issues, but the simulation may run faster with these values set to zero.

Dialog Box and Parameters

Main Tab

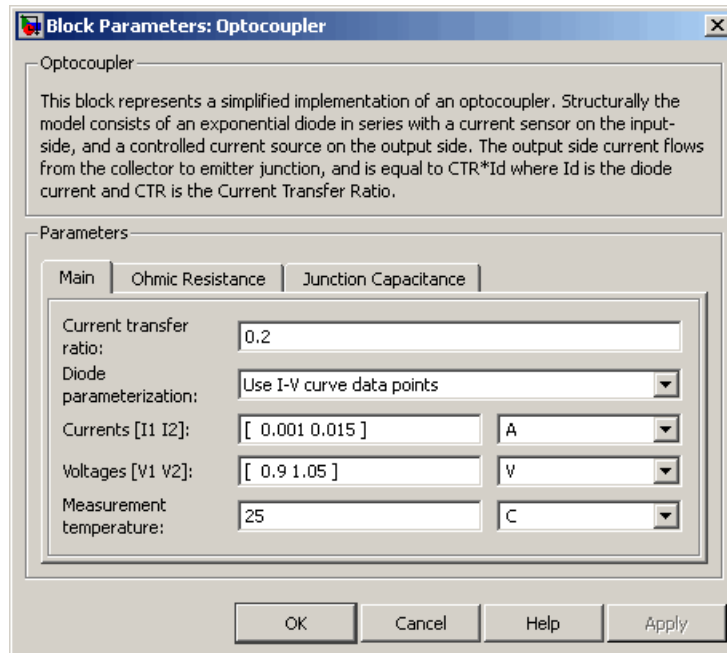

Current transfer ratio

The output current flowing from the transistor collector to emitter junctions is equal to the product of the current transfer ratio and the current flowing the light-emitting diode. The default value is 0.2.

Diode parameterization

Select one of the following methods for model parameterization:

- Use I-V curve data points — Specify measured data at two points on the diode I-V curve. This is the default method.
- Use parameters I_S and N — Specify saturation current and emission coefficient.

Currents [I1 I2]

A vector of the current values at the two points on the diode I-V curve that the block uses to calculate IS and N . This parameter is only visible when you select **Use I-V curve data points** for the **Diode parameterization** parameter. The default value is [0.001 0.015] A.

Voltages [V1 V2]

A vector of the voltage values at the two points on the diode I-V curve that the block uses to calculate IS and N . This parameter is only visible when you select **Use I-V curve data points** for the **Diode parameterization** parameter. The default value is [0.9 1.05] V.

Saturation current IS

The magnitude of the current that the ideal diode equation approaches asymptotically for very large reverse bias levels. This parameter is only visible when you select **Use parameters IS and N** for the **Diode parameterization** parameter. The default value is $1e-10$ A.

Measurement temperature

The temperature at which IS or the I-V curve was measured. The default value is 25 °C.

Emission coefficient N

The diode emission coefficient or ideality factor. This parameter is only visible when you select **Use parameters IS and N** for the **Diode parameterization** parameter. The default value is 2.

Ohmic Resistance Tab

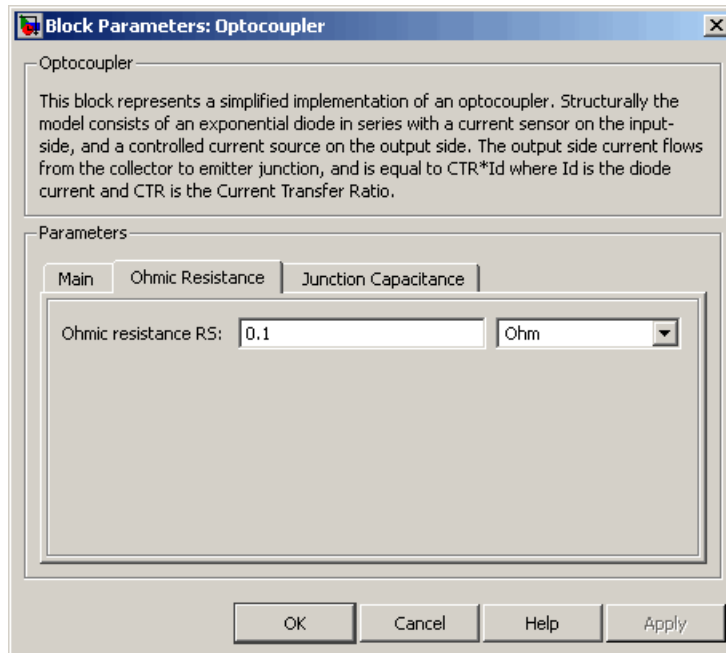

Ohmic resistance RS

The series diode connection resistance. The default value is 0.1 Ω .

Junction Capacitance Tab

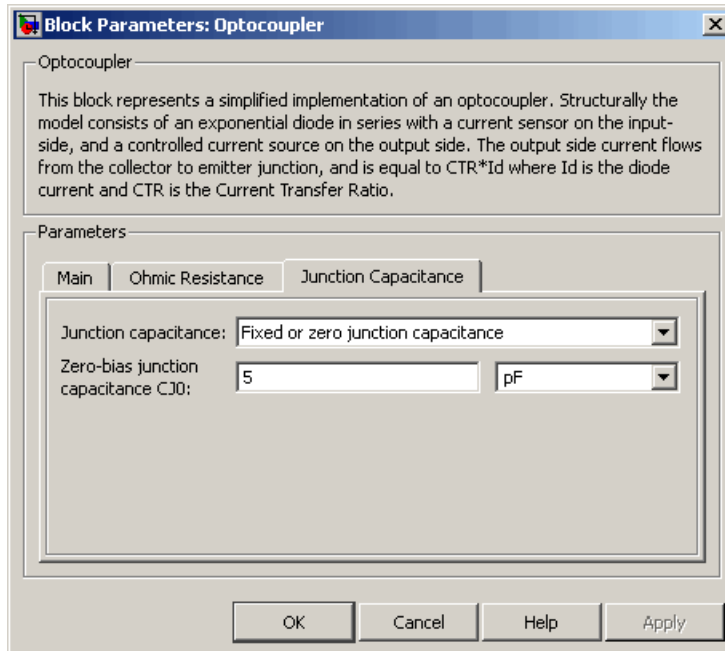

Junction capacitance

Select one of the following options for modeling the diode junction capacitance:

- Fixed or zero junction capacitance — Model the junction capacitance as a fixed value.
- Use C-V curve data points — Specify measured data at three points on the diode C-V curve.
- Use parameters C_{J0} , V_J , M & FC — Specify zero-bias junction capacitance, junction potential, grading coefficient, and forward-bias depletion capacitance coefficient.

Zero-bias junction capacitance CJO

The value of the capacitance placed in parallel with the exponential diode term. This parameter is only visible when you select Fixed or zero junction capacitance or Use parameters CJO, VJ, M & FC for the **Junction capacitance** parameter. The default value is 5 pF.

Junction potential VJ

The junction potential. This parameter is only visible when you select Use parameters CJO, VJ, M & FC for the **Junction capacitance** parameter. The default value is 1 V.

Grading coefficient M

The coefficient that quantifies the grading of the junction. This parameter is only visible when you select Use parameters CJO, VJ, M & FC for the **Junction capacitance** parameter. The default value is 0.5.

Reverse bias voltages [VR1 VR2 VR3]

A vector of the reverse bias voltage values at the three points on the diode C-V curve that the block uses to calculate *CJO*, *VJ*, and *M*. This parameter is only visible when you select Use C-V curve data points for the **Junction capacitance** parameter. The default value is [0.1 10 100] V.

Corresponding capacitances [C1 C2 C3]

A vector of the capacitance values at the three points on the diode C-V curve that the block uses to calculate *CJO*, *VJ*, and *M*. This parameter is only visible when you select Use C-V curve data points for the **Junction capacitance** parameter. The default value is [3.5 1 0.4] pF.

Capacitance coefficient FC

Fitting coefficient that quantifies the decrease of the depletion capacitance with applied voltage. This parameter is only visible when you select Use C-V curve data points or Use parameters CJO, VJ, M & FC for the **Junction capacitance** parameter. The default value is 0.5.

Optocoupler

Ports

The block has the following ports:

- +
Electrical conserving port associated with the diode positive terminal.
- Electrical conserving port associated with the diode negative terminal.
- C
Electrical conserving port associated with the transistor collector terminal.
- E
Electrical conserving port associated with the transistor emitter terminal.

References

- [1] G. Massobrio and P. Antognetti. *Semiconductor Device Modeling with SPICE*. 2nd Edition, McGraw-Hill, 1993.
- [2] H. Ahmed and P.J. Spreadbury. *Analogue and digital electronics for engineers*. 2nd Edition, Cambridge University Press, 1984.

See Also

Diode, NPN Bipolar Transistor, Simscape Controlled Current Source

Purpose Model P-Channel JFET

Library Semiconductor Devices

Description The P-Channel JFET block uses the Shichman and Hodges equations to represent a P-Channel JFET using a model with the following structure:



P-Channel JFET

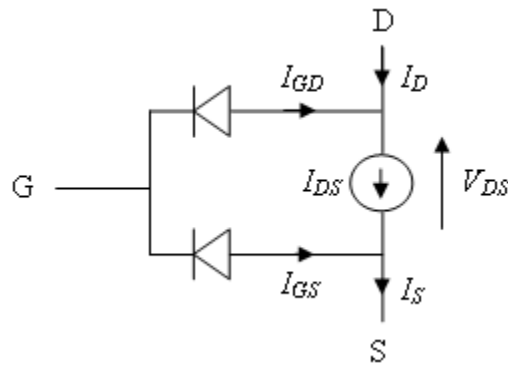

G is the transistor gate, D is the transistor drain and S is the transistor source. The drain-source current, I_{ds} , depends on the region of operation and whether the transistor is operating in normal or inverse mode.

- In normal mode ($-V_{ds} \geq 0$), the block provides the following relationship between the drain-source current I_{ds} and the drain-source voltage V_{ds} .

Region	Applicable Range of V_{gs} and V_{gd} Values	Corresponding I_{ds} Equation
Off	$-V_{gs} < -V_{i0}$	$I_{ds} = 0$

P-Channel JFET

Region	Applicable Range of V_{gs} and V_{gd} Values	Corresponding I_{ds} Equation
Linear	$0 < -V_{ds} < -V_{gs} + V_{t0}$	$I_{ds} = \beta V_{ds} (2(-V_{gs} + V_{t0}) + V_{ds})(1 - \lambda V_{ds})$
Saturated	$0 < -V_{gs} + V_{t0} < -V_{ds}$	$I_{ds} = -\beta(-V_{gs} + V_{t0})^2(1 - \lambda V_{ds})$

- In inverse mode ($V_{ds} < 0$), the block provides the following relationship between the drain-source current I_{ds} and the drain-source voltage V_{ds} .

Region	Applicable Range of V_{gd} and V_{ds} Values	Corresponding I_{ds} Equation
Off	$-V_{gd} < -V_{t0}$	$I_{ds} = 0$
Linear	$0 < V_{ds} < -V_{gd} + V_{t0}$	$I_{ds} = \beta V_{ds} (2(-V_{gd} + V_{t0}) - V_{ds})(1 + \lambda V_{ds})$
Saturated	$0 < -V_{gd} + V_{t0} < V_{ds}$	$I_{ds} = \beta(-V_{gd} + V_{t0})^2(1 + \lambda V_{ds})$

In the preceding equations:

- V_{gs} is the gate-source voltage.
- V_{gd} is the gate-drain voltage.
- V_{t0} is the threshold voltage. If you select Specify using equation parameters directly for the **Parameterization** parameter, V_{t0}

is the **Threshold voltage** parameter value. Otherwise, the block calculates V_{to} from the datasheet parameters you specify.

- β is the transconductance parameter. If you select **Specify** using equation parameters directly for the **Parameterization** parameter, β is the **Transconductance parameter** parameter value. Otherwise, the block calculates β from the datasheet parameters you specify.
- λ is the channel-length modulation parameter. If you select **Specify** using equation parameters directly for the **Parameterization** parameter, λ is the **Channel-length modulation** parameter value. Otherwise, the block calculates λ from the datasheet parameters you specify.

The currents in each of the diodes satisfy the exponential diode equation

$$I_{gd} = I_S \times \left(e^{\frac{qV_{gd}}{kT}} - 1 \right)$$
$$I_{gs} = I_S \times \left(e^{\frac{qV_{gs}}{kT}} - 1 \right)$$

Where:

- I_S is the saturation current. If you select **Specify** using equation parameters directly for the **Parameterization** parameter, I_S is the **Saturation current** parameter value. Otherwise, the block calculates I_S from the datasheet parameters you specify.
- q is the elementary charge on an electron.
- k is the Boltzmann constant.
- T is the diode temperature. The value comes from the **Measurement temperature** parameter.

P-Channel JFET

The block models gate junction capacitance as a fixed gate-drain capacitance C_{GD} and a fixed gate-source capacitance C_{GS} . If you select **Specify** using equation parameters directly for the **Parameterization** parameter, you specify these values directly using the **Gate-drain junction capacitance** and **Gate-source junction capacitance** parameters. Otherwise, the block derives them from the **Input capacitance** C_{iss} and **Reverse transfer capacitance** C_{rss} parameter values. The two parameterizations are related as follows:

- $C_{GD} = C_{rss}$
- $C_{GS} = C_{iss} - C_{rss}$

Basic Assumptions and Limitations

The model is based on the following assumptions:

- This block does not allow you to specify initial conditions on the junction capacitances. If you select the **Start simulation from steady state** option in the Solver Configuration block, the block solves the initial voltages to be consistent with the calculated steady state. Otherwise, voltages are zero at the start of the simulation.
- This block does not model temperature-dependent effects. SimElectronics simulates the block at the temperature at which the component behavior was measured, as specified by the **Measurement temperature** parameter value.
- You may need to use nonzero ohmic resistance and junction capacitance values to prevent numerical simulation issues, but the simulation may run faster with these values set to zero.

Dialog Box and Parameters

Main Tab

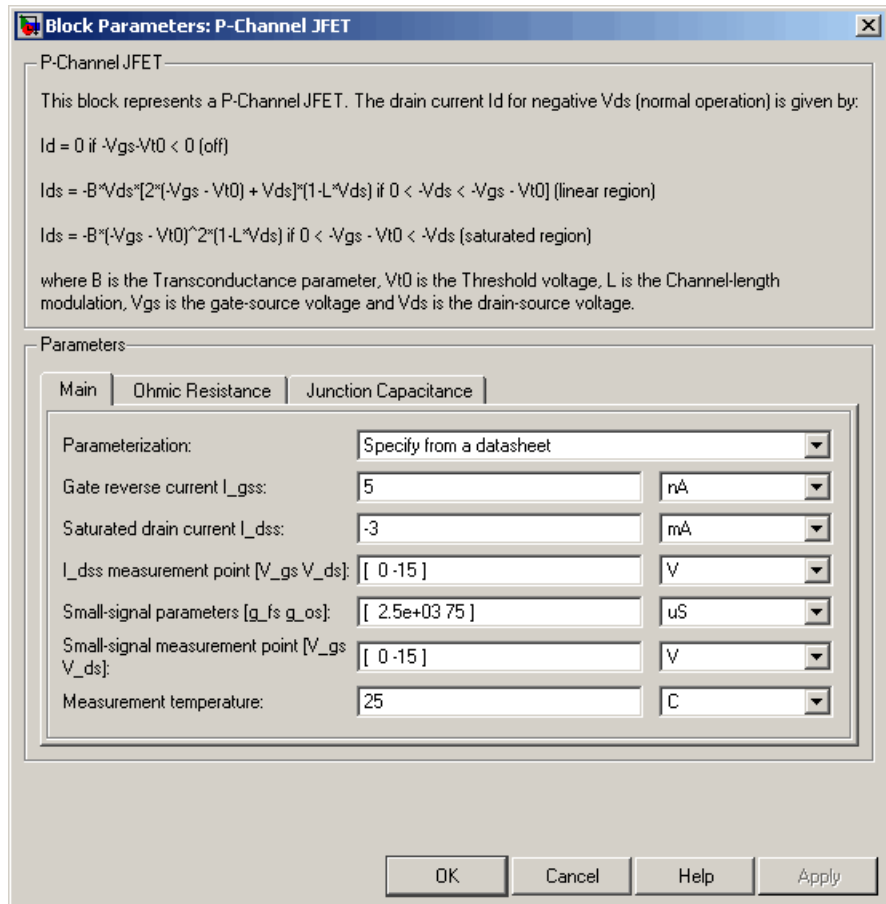

Parameterization

Select one of the following methods for block parameterization:

- **Specify from a datasheet** — Provide parameters that the block converts to equations that describe the transistor. This is the default method.

- Specify using equation parameters directly — Provide equation parameters V_{to} , β , λ , and I_S .

Gate reverse current **I_gss**

The reverse current that flows in the diode when the drain and source are short-circuited and a large positive gate-source voltage is applied. This parameter is only visible when you select **Specify** from a datasheet for the **Parameterization** parameter. The default value is 5 nA.

Saturated drain current **I_dss**

The current that flows when a large negative drain-source voltage is applied for a specified gate-source voltage. For a depletion-mode device, this gate-source voltage may be zero, in which case I_{dss} may be referred to as the zero-gate voltage drain current. This parameter is only visible when you select **Specify** from a datasheet for the **Parameterization** parameter. The default value is -3 mA.

I_dss measurement point [**V_gs V_ds**]

A vector of the values of V_{gs} and V_{ds} at which I_{dss} is measured. Normally V_{gs} is zero. V_{ds} should be less than zero. This parameter is only visible when you select **Specify** from a datasheet for the **Parameterization** parameter. The default value is [0 -15] V.

Small-signal parameters [**g_fs g_os**]

A vector of the values of g_{fs} and g_{os} . g_{fs} is the forward transfer conductance, i.e. the conductance for a fixed drain-source voltage. g_{os} is the output conductance, i.e. the conductance for a fixed gate-source voltage. This parameter is only visible when you select **Specify** from a datasheet for the **Parameterization** parameter. The default value is [2.5e+03 75] uS.

Small-signal measurement point [**V_gs V_ds**]

A vector of the values of V_{gs} and V_{ds} at which g_{fs} and g_{os} are measured. V_{ds} should be less than zero. For depletion-mode devices, V_{gs} is typically zero. This parameter is only visible when you select **Specify** from a datasheet for the **Parameterization** parameter. The default value is [0 -15] V.

Transconductance parameter

The derivative of drain current with respect to gate voltage. This parameter is only visible when you select **Specify using equation parameters directly** for the **Parameterization** parameter. The default value is $1e-04 \text{ A/V}^2$.

Saturation current

The magnitude of the current that the ideal diode equation approaches asymptotically for very large reverse bias levels. This parameter is only visible when you select **Specify using equation parameters directly** for the **Parameterization** parameter. The default value is $1e-14 \text{ A}$.

Measurement temperature

The temperature for which the datasheet parameters are quoted. It is also the temperature at which the device is simulated. The default value is 25 C .

Threshold voltage

The gate-source voltage above which the transistor produces a nonzero drain current. For an enhancement device, V_{t0} should be negative. For a depletion mode device, V_{t0} should be positive. This parameter is only visible when you select **Specify using equation parameters directly** for the **Parameterization** parameter. The default value is 2 V .

Channel-length modulation

The channel-length modulation. This parameter is only visible when you select **Specify using equation parameters directly** for the **Parameterization** parameter. The default value is 0 1/V .

P-Channel JFET

Ohmic Resistance Tab

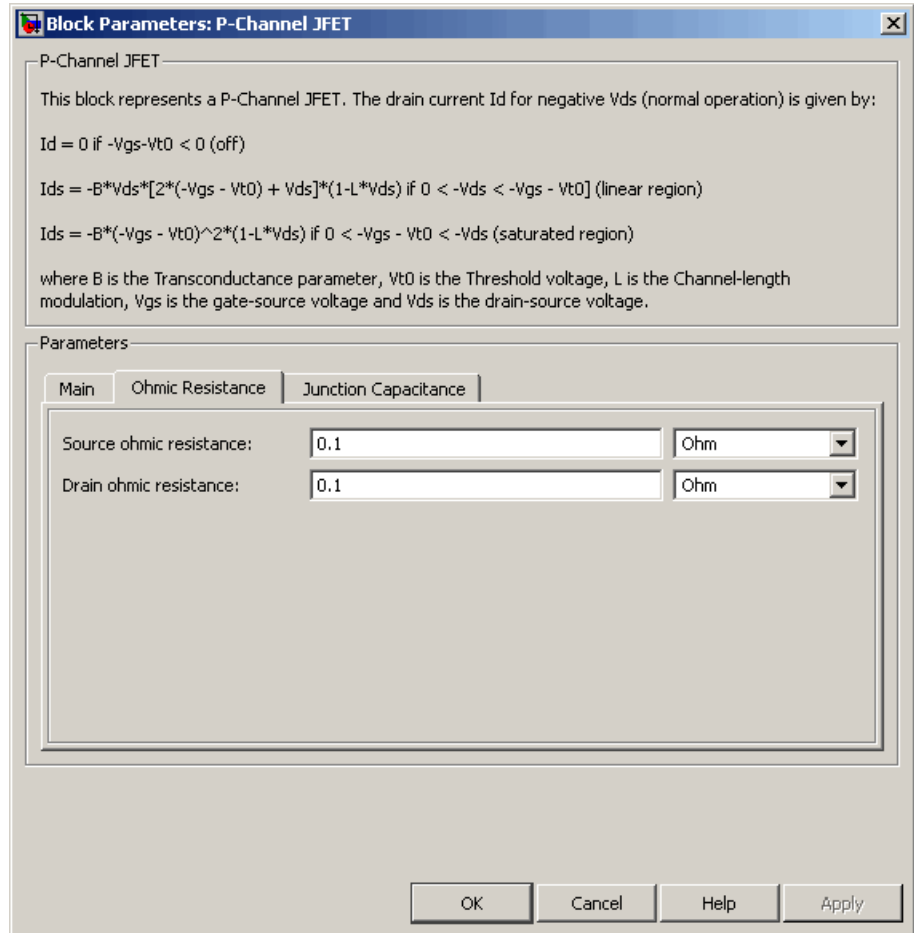

Source ohmic resistance

The transistor source resistance. The default value is 0.1 Ω . The value must be greater than or equal to 0.

Drain ohmic resistance

The transistor drain resistance. The default value is 0.1 Ω . The value must be greater than or equal to 0.

Junction Capacitance Tab

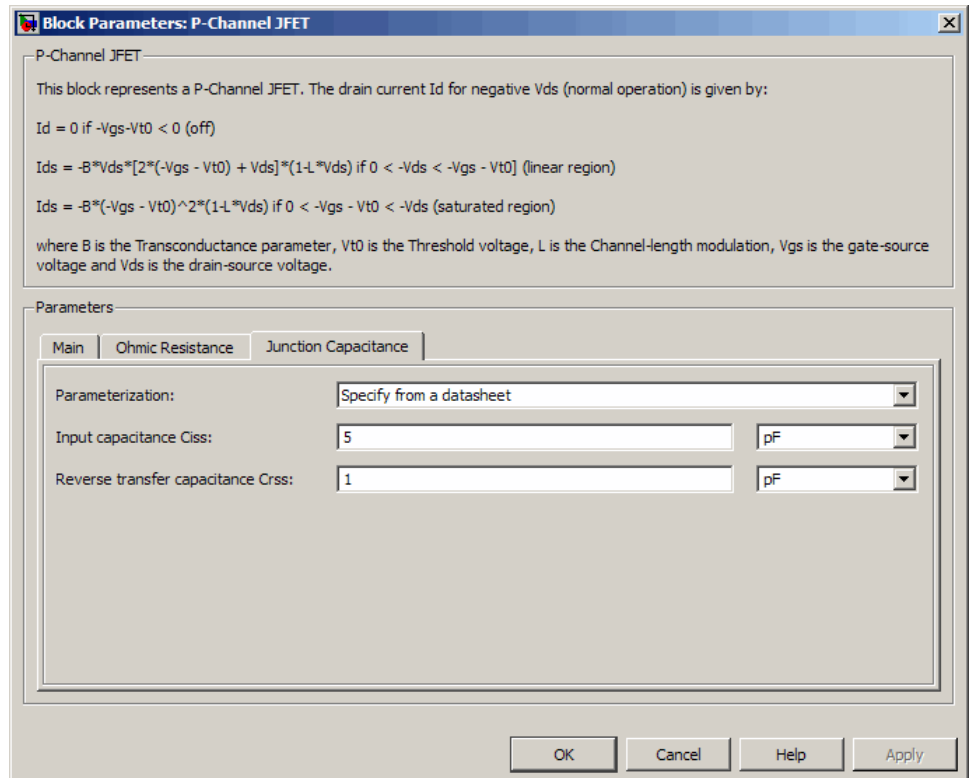

Parameterization

Select one of the following methods for block parameterization:

- **Specify from a datasheet** — Provide parameters that the block converts to junction capacitance values. This is the default method.

P-Channel JFET

- Specify using equation parameters directly — Provide junction capacitance parameters directly.

Input capacitance C_{iss}

The gate-source capacitance with the drain shorted to the source. This parameter is only visible when you select **Specify** from a datasheet for the **Model junction capacitance** parameter. The default value is 4.5 pF.

Reverse transfer capacitance C_{rss}

The drain-gate capacitance with the source connected to ground. This parameter is only visible when you select **Specify** from a datasheet for the **Model junction capacitance** parameter. The default value is 1.5 pF.

Gate-source junction capacitance

The value of the capacitance placed between the gate and the source. This parameter is only visible when you select **Specify** using equation parameters directly for the **Model junction capacitance** parameter. The default value is 3 pF.

Gate-drain junction capacitance

The value of the capacitance placed between the gate and the drain. This parameter is only visible when you select **Specify** using equation parameters directly for the **Model junction capacitance** parameter. The default value is 1.5 pF.

Ports

The block has the following ports:

G

Electrical conserving port associated with the transistor gate terminal.

D

Electrical conserving port associated with the transistor drain terminal.

S

Electrical conserving port associated with the transistor source terminal.

References

[1] H. Shichman and D. A. Hodges, *Modeling and simulation of insulated-gate field-effect transistor switching circuits*. IEEE J. Solid State Circuits, SC-3, 1968.

[2] G. Massobrio and P. Antognetti. *Semiconductor Device Modeling with SPICE*. 2nd Edition, McGraw-Hill, 1993. Chapter 2.

See Also

N-Channel JFET

P-Channel MOSFET

Purpose Model P-Channel MOSFET using Shichman-Hodges equation

Library Semiconductor Devices

Description The P-Channel MOSFET block uses the Shichman and Hodges equations [1] for an insulated-gate field-effect transistor to represent an P-Channel MOSFET.



P-Channel MOSFET

The drain-source current, I_{DS} , depends on the region of operation:

- In the off region ($-V_{GS} < -V_{th}$) the drain-source current is:

$$I_{DS} = 0$$

- In the linear region ($0 < -V_{DS} < -V_{GS} + V_{th}$) the drain-source current is:

$$I_{DS} = -K \left((V_{GS} - V_{th})V_{DS} - V_{DS}^2 / 2 \right)$$

- In the saturated region ($0 < -V_{GS} + V_{th} < -V_{DS}$) the drain-source current is:

$$I_{DS} = -(K/2)(V_{GS} - V_{th})^2$$

In the preceding equations:

- K is the transistor gain.
- V_{DS} is the negative drain-source voltage.
- V_{GS} is the gate-source voltage.
- V_{th} is the threshold voltage.

The block models gate junction capacitance as a fixed gate-drain capacitance C_{GD} and a fixed gate-source capacitance C_{GS} . If you

select **Specify** using equation parameters directly for the **Parameterization** parameter in the **Junction Capacitance** tab, you specify these values directly using the **Gate-drain junction capacitance** and **Gate-source junction capacitance** parameters. Otherwise, the block derives them from the **Input capacitance** C_{iss} and **Reverse transfer capacitance** C_{rss} parameter values. The two parameterizations are related as follows:

- $C_{GD} = C_{rss}$
- $C_{GS} = C_{iss} - C_{rss}$

P-Channel MOSFET

Dialog Box and Parameters

Main Tab

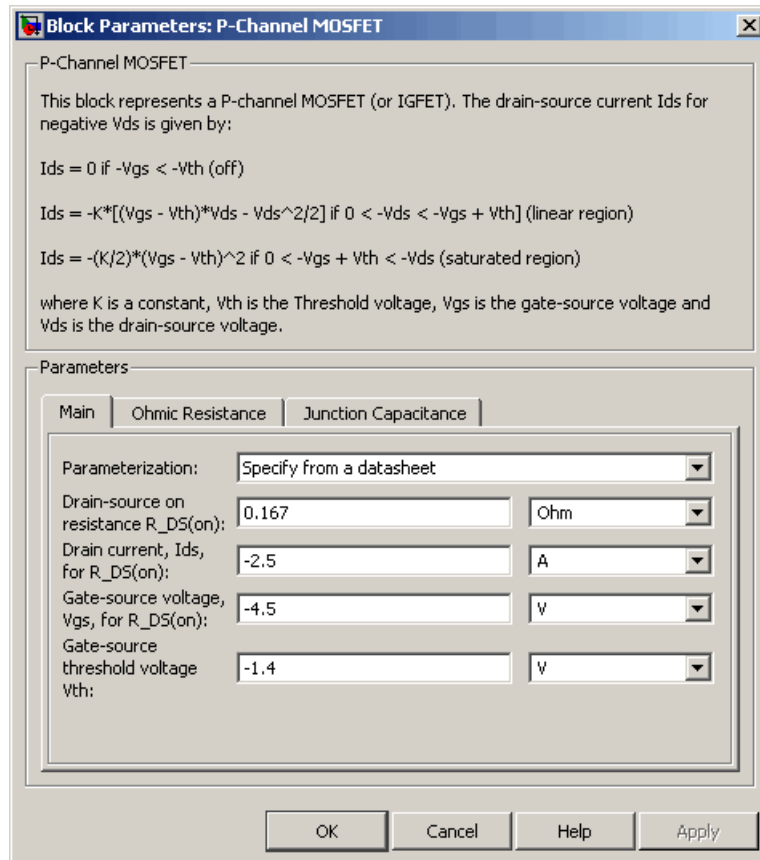

Parameterization

Select one of the following methods for block parameterization:

- **Specify from a datasheet** — Provide the drain-source on resistance and the corresponding drain current and gate-source voltage. The block calculates the transistor gain for the

Shichman and Hodges equations from this information. This is the default method.

- Specify using equation parameters directly — Provide the transistor gain.

Drain-source on resistance, R_DS(on)

The ratio of the drain-source voltage to the drain current for specified values of drain current and gate-source voltage.

$R_{DS(on)}$ should have a positive value. This parameter is only visible when you select **Specify** from a datasheet for the **Parameterization** parameter. The default value is 0.167 Ω .

Drain current, Ids, for R_DS(on)

The drain current the block uses to calculate the value of the drain-source resistance. I_{DS} should have a negative value. This parameter is only visible when you select **Specify** from a datasheet for the **Parameterization** parameter. The default value is -2.5 A.

Gate-source voltage, Vgs, for R_DS(on)

The gate-source voltage the block uses to calculate the value of the drain-source resistance. V_{GS} should have a negative value. This parameter is only visible when you select **Specify** from a datasheet for the **Parameterization** parameter. The default value is -4.5 V.

Gain K

Positive constant gain coefficient for the Shichman and Hodges equations. This parameter is only visible when you select **Specify using equation parameters directly** for the **Parameterization** parameter. The default value is 2 A/V².

Gate-source threshold voltage Vth

Gate-source threshold voltage V_{th} in the Shichman and Hodges equations. For an enhancement device, V_{th} should be negative. For a depletion mode device, V_{th} should be positive. The default value is -1.4 V.

P-Channel MOSFET

Ohmic Resistance Tab

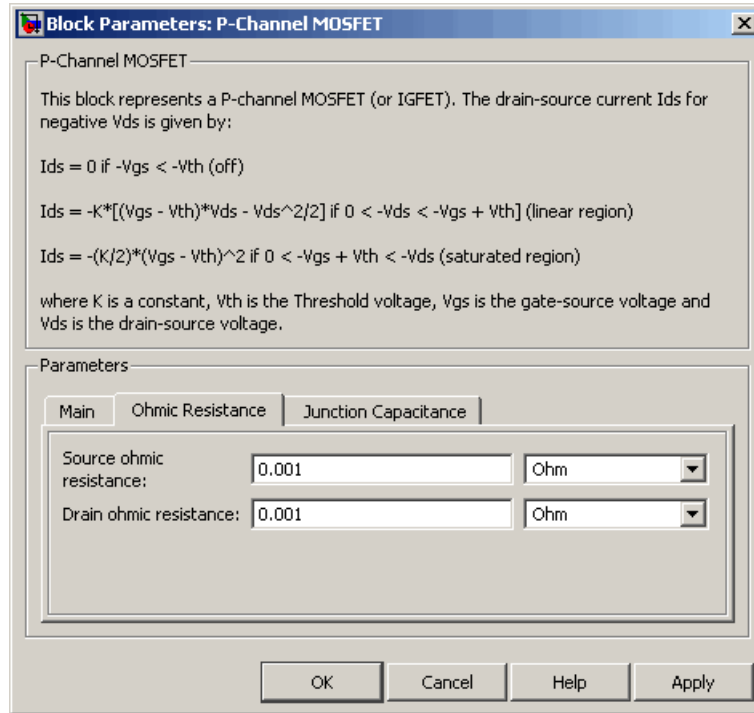

Source ohmic resistance

The transistor source resistance. The default value is 0.001 Ω .
The value must be greater than or equal to 0.

Drain ohmic resistance

The transistor drain resistance. The default value is 0.001 Ω .
The value must be greater than or equal to 0.

Junction Capacitance Tab

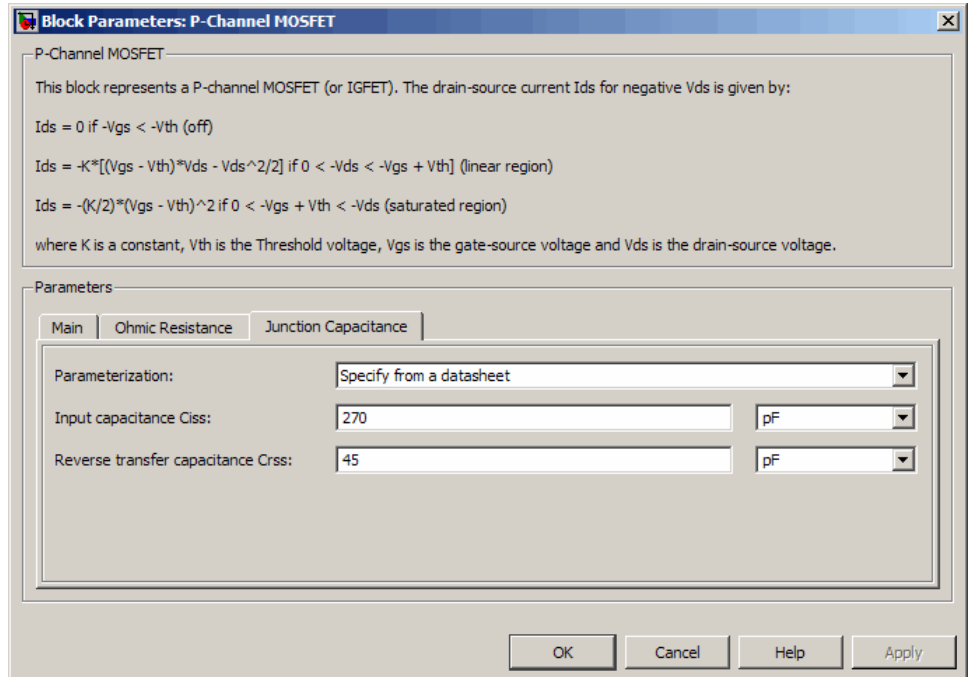

Parameterization

Select one of the following methods for capacitance parameterization:

- **Specify from a datasheet** — Provide parameters that the block converts to junction capacitance values. This is the default method.
- **Specify using equation parameters directly** — Provide junction capacitance parameters directly.

Input capacitance C_{iss}

The gate-source capacitance with the drain shorted to the source. This parameter is only visible when you select **Specify from a**

P-Channel MOSFET

datasheet for the **Parameterization** parameter. The default value is 270 pF.

Reverse transfer capacitance Crss

The drain-gate capacitance with the source connected to ground. This parameter is only visible when you select **Specify** from a datasheet for the **Parameterization** parameter. The default value is 45 pF.

Gate-source junction capacitance

The value of the capacitance placed between the gate and the source. This parameter is only visible when you select **Specify using equation parameters directly** for the **Parameterization** parameter. The default value is 225 pF.

Gate-drain junction capacitance

The value of the capacitance placed between the gate and the drain. This parameter is only visible when you select **Specify using equation parameters directly** for the **Parameterization** parameter. The default value is 45 pF.

Ports

The block has the following ports:

G

Electrical conserving port associated with the transistor gate terminal.

D

Electrical conserving port associated with the transistor drain terminal.

S

Electrical conserving port associated with the transistor source terminal.

References

[1] H. Shichman and D. A. Hodges. "Modeling and simulation of insulated-gate field-effect transistor switching circuits." IEEE J. Solid State Circuits, SC-3, 1968.

See Also N-Channel MOSFET

Purpose Model polynomial current-controlled current source

Library SPICE-Compatible Sources

Description The PCCCS (Polynomial Current-Controlled Current Source) block represents a current source whose output current value is a polynomial function of the current through the input ports. The following equations describe the current through the source as a function of time:

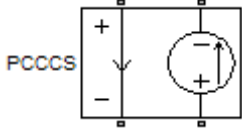

- If you specify an n -element vector of polynomial coefficients for the **Polynomial coefficients** parameter:

$$I_{out} = p(0) + p(1) * I_{in} + \dots + p(n - 1) * I_{in}^{n-1} + p(n) * I_{in}^n$$

- If you specify a scalar coefficient for the **Polynomial coefficients** parameter:

$$I_{out} = p * I_{in}$$

where:

- I_{in} is the current through the input ports.
- p is the **Polynomial coefficients** parameter value.

The block uses a small conductance internally to prevent numerical simulation issues. The conductance connects the output ports of the device and has a conductance $GMIN$:

- By default, $GMIN$ matches the **Minimum conductance GMIN** parameter of the SPICE Environment Parameters block, whose default value is $1e-12$.
- To change $GMIN$, add a SPICE Environment Parameters block to your model and set the **Minimum conductance GMIN** parameter to the desired value.

Dialog Box and Parameters

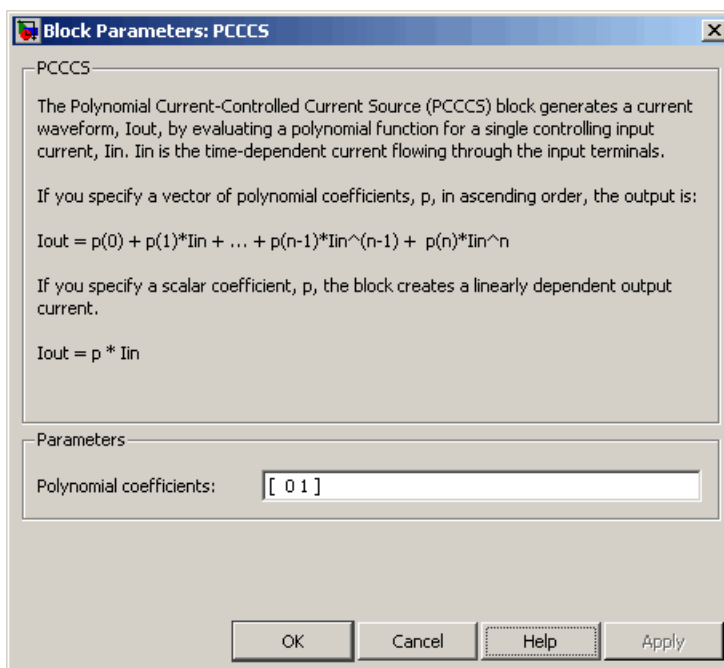

Polynomial coefficients

The polynomial coefficients that relate the input current to the output current, as described in the preceding section. The default value is [0 1].

Ports

The block has the following ports:

- + Positive electrical input voltage.
- Negative electrical input voltage.
- N+ Positive electrical output voltage.

PCCCS

N-
Negative electrical output voltage.

See Also , PCCCS2PCCVS, PVCSS, and PVCVS

Purpose

Model polynomial current-controlled current source with two controlling inputs

Library

SPICE-Compatible Sources

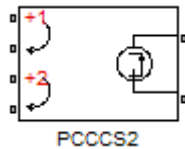
Description

The PCCCS2 (Two-Input Polynomial Current-Controlled Current Source) block represents a current source whose output current value is a polynomial function of the currents through the pairs of controlling input ports. The following equations describes the current through the source as a function of time:

$$I_{out} = p_1 + p_2 * I_{in1} + p_3 * I_{in2} + p_4 * I_{in1}^2 + p_5 I_{in1} * I_{in2} + p_6 * I_{in2}^2 + \dots$$

where:

- I_{in1} is the current across the first pair of input ports.
- I_{in2} is the current across the second pair of input ports.
- p is the **Polynomial coefficients** parameter value.

The block uses a small conductance internally to prevent numerical simulation issues. The conductance connects the output ports of the device and has a conductance $GMIN$:

- By default, $GMIN$ matches the **Minimum conductance GMIN** parameter of the SPICE Environment Parameters block, whose default value is 1e-12.
- To change $GMIN$, add a SPICE Environment Parameters block to your model and set the **Minimum conductance GMIN** parameter to the desired value.

Dialog Box and Parameters

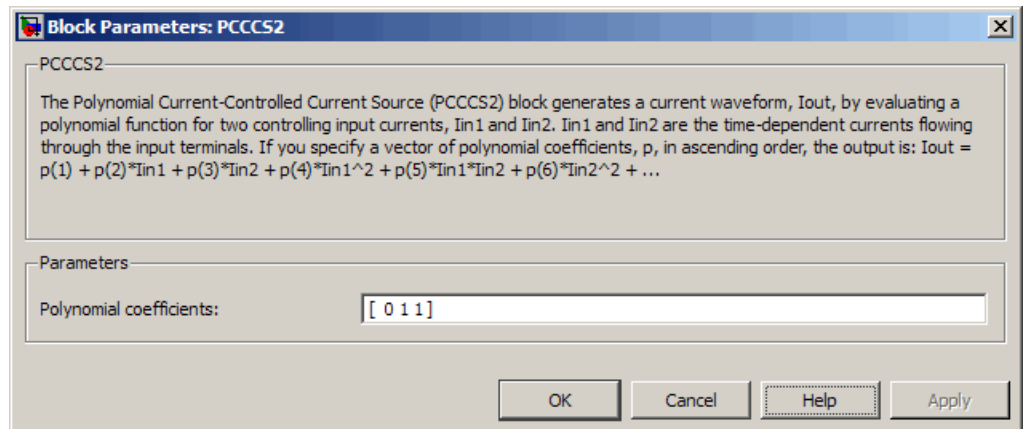

Polynomial coefficients

The polynomial coefficients that relate the input current to the output current, as described in the preceding section. The default value is [0 1 1].

Ports

The block has the following ports:

- +1 Positive electrical input voltage of first controlling source.
- 1 Negative electrical input voltage of first controlling source.
- +2 Positive electrical input voltage of second controlling source.
- 2 Negative electrical input voltage of second controlling source.
- N+ Positive electrical output voltage.
- N- Negative electrical output voltage.

See Also PCCCS, PCCVS2, PVCCS2, and PVCVS2

Purpose Model polynomial current-controlled voltage source

Library SPICE-Compatible Sources

Description The PCCVS (Polynomial Current-Controlled Voltage Source) block represents a voltage source whose output voltage value is a polynomial function of the current through the input ports. The following equations describe the voltage across the source as a function of time:

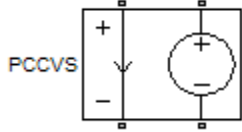

- If you specify an n -element vector of polynomial coefficients for the **Polynomial coefficients** parameter:

$$V_{out} = p(0) + p(1) * I_{in} + \dots + p(n-1) * I_{in}^{n-1} + p(n) * I_{in}^n$$

- If you specify a scalar coefficient for the **Polynomial coefficients** parameter:

$$V_{out} = p * I_{in}$$

where:

- I_{in} is the current through the input ports.
- p is the **Polynomial coefficients** parameter value.

Dialog Box and Parameters

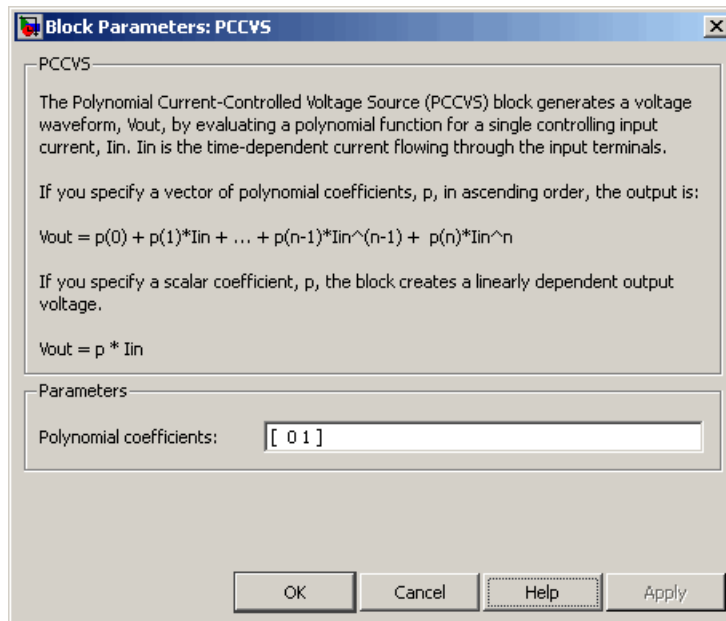

Polynomial coefficients

The polynomial coefficients that relate the input current to the output voltage, as described in the preceding section. The default value is [0 1].

Ports

The block has the following ports:

- + Positive electrical input voltage.
- Negative electrical input voltage.
- N+ Positive electrical output voltage.
- N- Negative electrical output voltage.

PCCVS

See Also

PCCCS, PCCVS2, PVCCS, and PVCVS

Purpose

Model polynomial current-controlled voltage source with two controlling inputs

Library

SPICE-Compatible Sources

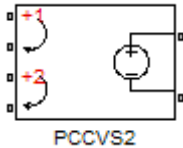
Description

The PCCVS2 (Two-Input Polynomial Current-Controlled Voltage Source) block represents a voltage source whose output voltage value is a polynomial function of the currents through the pairs of controlling input ports. The following equations describes the voltage across the source as a function of time:

$$V_{out} = p_1 + p_2 * I_{in1} + p_3 * I_{in2} + p_4 * I_{in1}^2 + p_5 I_{in1} * I_{in2} + p_6 * I_{in2}^2 + \dots$$

where:

- I_{in1} is the current across the first pair of input ports.
- I_{in2} is the current across the second pair of input ports.
- p is the **Polynomial coefficients** parameter value.

The block uses a small conductance internally to prevent numerical simulation issues. The conductance connects the output ports of the device and has a conductance $GMIN$:

- By default, $GMIN$ matches the **Minimum conductance GMIN** parameter of the SPICE Environment Parameters block, whose default value is $1e-12$.
- To change $GMIN$, add a SPICE Environment Parameters block to your model and set the **Minimum conductance GMIN** parameter to the desired value.

PCCVS2

Dialog Box and Parameters

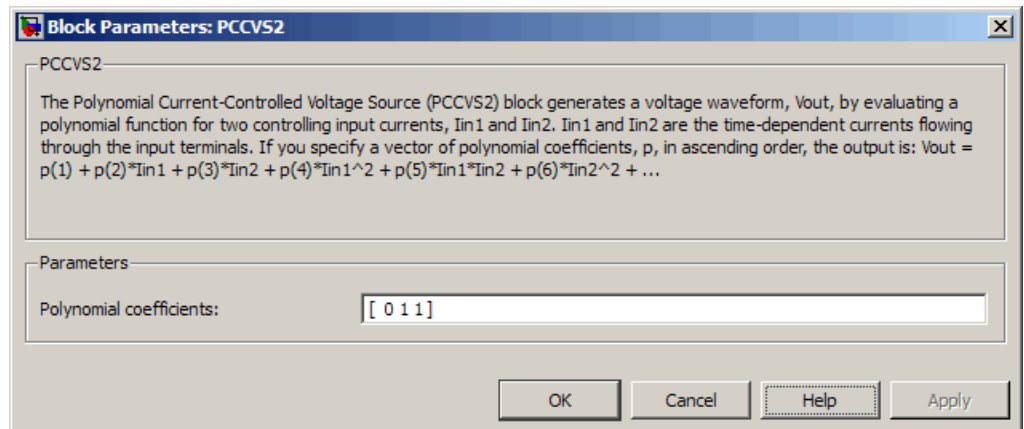

Polynomial coefficients

The polynomial coefficients that relate the input current to the output voltage, as described in the preceding section. The default value is [0 1 1].

Ports

The block has the following ports:

- +1 Positive electrical input voltage of first controlling source.
- 1 Negative electrical input voltage of first controlling source.
- +2 Positive electrical input voltage of second controlling source.
- 2 Negative electrical input voltage of second controlling source.
- N+ Positive electrical output voltage.
- N- Negative electrical output voltage.

See Also PCCCS2, PCCVS, PVCCS2, and PVCVS2

Photodiode

Purpose

Model photodiode as parallel controlled current source and exponential diode

Library

Sensors

Description



Photodiode

The Photodiode block represents a photodiode as a controlled current source and an exponential diode connected in parallel. The controlled current source produces a current I_p that is proportional to the radiant flux density:

$$I_p = DeviceSensitivity \times RadiantFluxDensity$$

where:

- *DeviceSensitivity* is the ratio of the current produced to the incident radiant flux density.
 - If you select Specify measured current for given flux density for the **Sensitivity parameterization** parameter, the block calculates this variable by converting the **Measured current** parameter value to units of amps and dividing it by the **Flux density** parameter values.
 - If you select Specify current per unit flux density for the **Sensitivity parameterization** parameter, this variable is defined by the **Device sensitivity** parameter value.
- *RadiantFluxDensity* is the incident radiant flux density.

To model dynamic response time, use the **Junction capacitance** parameter to include the diode junction capacitance in the model.

The exponential diode model provides the following relationship between the diode current I and the diode voltage V :

$$I = IS \times \left(e^{\frac{qV}{NkT}} - 1 \right)$$

where:

- q is the elementary charge on an electron (1.602176e-19 Coulombs).
- k is the Boltzmann constant (1.3806503e-23 J/K).
- N is the emission coefficient.
- IS is the saturation current, which is equal to the **Dark current** parameter value.
- T is the temperature at which the diode parameters are specified, as defined by the **Measurement temperature** parameter value.

When $\frac{qV}{NkT} > 80$, the block replaces $e^{\frac{qV}{NkT}}$ with $\left(\frac{qV}{NkT} - 79\right)e^{80}$, which matches the gradient of the diode current at $qV/(NkT) = 80$ and extrapolates linearly. When $\frac{qV}{NkT} < -79$, the block replaces $e^{\frac{qV}{NkT}}$ with $\left(\frac{qV}{NkT} + 80\right)e^{-79}$, which also matches the gradient and extrapolates linearly. Typical electrical circuits do not reach these extreme values. The block provides this linear extrapolation to help convergence when solving for the constraints during simulation.

When you select Use dark current and N for the **Diode parameterization** parameter, you specify the diode in terms of the **Dark current** and **Emission coefficient N** parameters. When you select Use dark current plus a forward bias I-V data point for the **Diode parameterization** parameter, you specify the **Dark current** parameter and a voltage and current measurement point on the diode I-V curve. The block calculates N from these values as follows:

$$N = V_F / (V_t \log(I_F / IS + 1))$$

where:

- V_F is the **Forward voltage VF** parameter value.

- $V_t = kT / q$.
- I_F is the **Current IF at forward voltage VF** parameter value.

The exponential diode model provides the option to include a junction capacitance:

- When you select **Fixed** or **zero** junction capacitance for the **Junction capacitance** parameter, the capacitance is fixed.
- When you select **Use parameters CJO, VJ, M & FC** for the **Junction capacitance** parameter, the block uses the coefficients *CJO*, *VJ*, *M*, and *FC* to calculate a junction capacitance that depends on the junction voltage.
- When you select **Use C-V curve data points** for the **Junction capacitance** parameter, the block uses three capacitance values on the C-V capacitance curve to estimate *CJO*, *VJ* and *M* and uses these values with the specified value of *FC* to calculate a junction capacitance that depends on the junction voltage. The block calculates *CJO*, *VJ* and *M* as follows:

$$- CJO = C_1((V_{R2} - V_{R1}) / (V_{R2} - V_{R1}(C_2 / C_1)^{-1/M}))^M$$

$$- VJ = -(-V_{R2}(C_1 / C_2)^{-1/M} + V_{R1}) / (1 - (C_1 / C_2)^{-1/M})$$

$$- M = \log(C_3 / C_2) / \log(V_{R2} / V_{R3})$$

where:

- V_{R1} , V_{R2} , and V_{R3} are the values in the **Reverse bias voltages [VR1 VR2 VR3]** vector.
- C_1 , C_2 , and C_3 are the values in the **Corresponding capacitances [C1 C2 C3]** vector.

It is not possible to estimate *FC* reliably from tabulated data, so you must specify its value using the **Capacitance coefficient FC** parameter. In the absence of suitable data for this parameter, use a typical value of 0.5.

The reverse bias voltages (defined as positive values) should satisfy $V_{R3} > V_{R2} > V_{R1}$. This means that the capacitances should satisfy $C_1 > C_2 > C_3$ as reverse bias widens the depletion region and hence reduces capacitance. Violating these inequalities results in an error. Voltages V_{R2} and V_{R3} should be well away from the Junction potential VJ . Voltage V_{R1} should be less than the Junction potential VJ , with a typical value for V_{R1} being 0.1 V.

The voltage-dependent junction is defined in terms of the capacitor charge storage Q_j as:

- For $V < FC \times VJ$:

$$Q_j = CJO \times (VJ / (M - 1)) \times ((1 - V / VJ)^{1-M} - 1)$$

- For $V \geq FC \times VJ$:

$$Q_j = CJO \times F_1 + (CJO / F_2) \times (F_3 \times (V - FC \times VJ) + 0.5 * (M / VJ) * (V^2 - (FC \times VJ)^2))$$

where:

- $F_1 = (VJ / (1 - M)) \times (1 - (1 - FC)^{1-M})$
- $F_2 = (1 - FC)^{1+M}$
- $F_3 = 1 - FC \times (1 + M)$

These equations are the same as used in [2], except that the temperature dependence of VJ and FC is not modeled. This model does not include the diffusion capacitance term that affects performance for high frequency switching applications.

Photodiode

Basic Assumptions and Limitations

The Photodiode block has the following limitations:

- When you select Use dark current plus a forward bias I-V curve data point for the **Diode parameterization** parameter, choose a voltage near the diode turn-on voltage. Typically this will be in the range from 0.05 to 1 Volt. Using a value outside of this region may lead to a poor estimate for N .
- This block does not model temperature-dependent effects. SimElectronics simulates the block at the temperature at which the component behavior was measured, as specified by the **Measurement temperature** parameter value.
- You may need to use nonzero ohmic resistance and junction capacitance values to prevent numerical simulation issues, but the simulation may run faster with these values set to zero.

Dialog Box and Parameters

Main Tab

Photodiode

This block represents a photodiode. Structurally it consists of a controlled current source and an exponential diode connected in parallel. The controlled current source produces a current I_p that is proportional to the Radiant flux density presented at the physical signal port D:

$$I_p = \text{Device sensitivity} * \text{Radiant flux density}$$

In order to model dynamic response time, the diode junction capacitance can set to a suitable value.

Parameters

Main | Ohmic Resistance | Junction Capacitance

Sensitivity parameterization:	Specify measured current for given flux density	
Measured current:	25	uA
Flux density:	5	W/m ²
Diode parameterization:	Use dark current plus a forward bias I-V data point	
Current I_F at forward voltage V_F :	0.08	A
Forward voltage V_F :	1.3	V
Dark current:	5e-09	A
Measurement temperature:	25	C

OK Cancel Help Apply

Sensitivity parameterization

Select one of the following methods for sensitivity parameterization:

- Specify measured current for given flux density — Specify the measured current and the corresponding flux density. This is the default method.

- Specify current per unit flux density — Specify the device sensitivity directly.

Measured current

The current the block uses to calculate the device sensitivity. This parameter is only visible when you select **Specify measured current for given flux density** for the **Sensitivity parameterization** parameter. The default value is 25 μA .

Flux density

The flux density the block uses to calculate the device sensitivity. This parameter is only visible when you select **Specify measured current for given flux density** for the **Sensitivity parameterization** parameter. The default value is 5 W/m^2 .

Device sensitivity

The current per unit flux density. This parameter is only visible when you select **Specify current per unit flux density** for the **Sensitivity parameterization** parameter. The default value is $5\text{e-}06 \text{ m}^2\cdot\text{A}/\text{W}$.

Diode parameterization

Select one of the following methods for diode model parameterization:

- Use dark current plus a forward bias I-V data point — Specify the dark current and a point on the diode I-V curve. This is the default method.
- Use dark current and N — Specify dark current and emission coefficient.

Current IF at forward voltage VF

The current at the forward-biased point on the diode I-V curve that the block uses to calculate I_S and N . This parameter is only visible when you select **Use dark current plus a forward bias I-V data point** for the **Diode parameterization** parameter. The default value is 0.08 A.

Forward voltage VF

The corresponding voltage at the forward-biased point on the diode I-V curve that the block uses to calculate IS and N .

This parameter is only visible when you select and Use dark current plus a forward bias I-V data point for the **Diode parameterization** parameter. The default value is 1.3 V.

Dark current

The current through the diode when it is not exposed to light.

The default value is 5e-09 A.

Measurement temperature

The temperature at which the I-V curve or dark current was measured. The default value is 25 °C.

Emission coefficient N

The diode emission coefficient or ideality factor. This parameter is only visible when you select Use dark current and N for the **Diode parameterization** parameter. The default value is 3.

Photodiode

Ohmic Resistance Tab

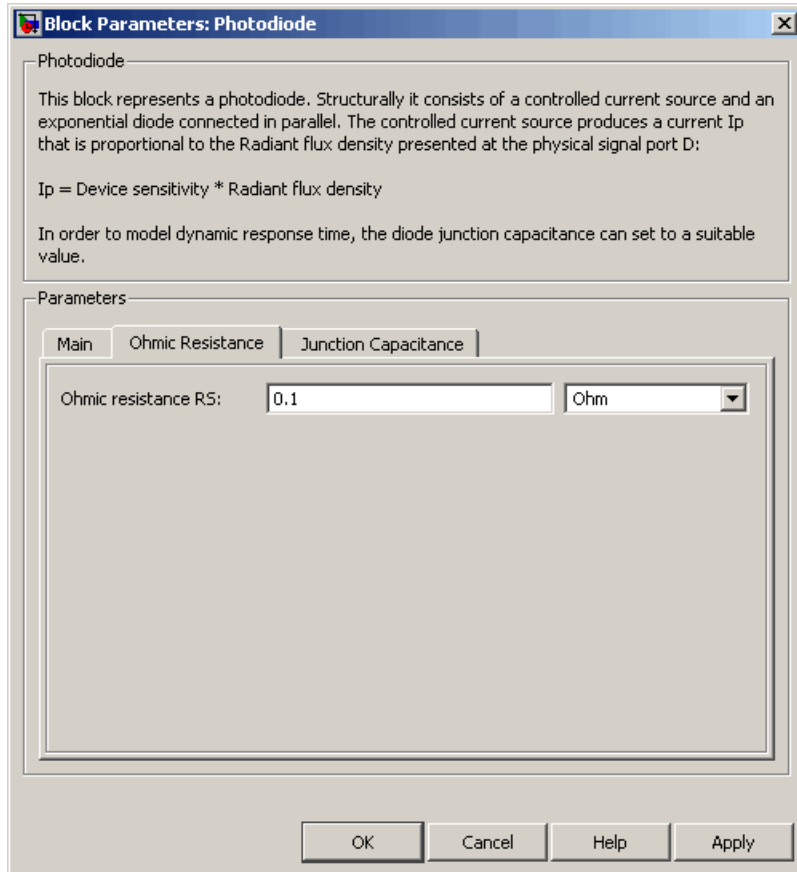

Ohmic resistance RS

The series diode connection resistance. The default value is 0.1 Ω .

Junction Capacitance Tab

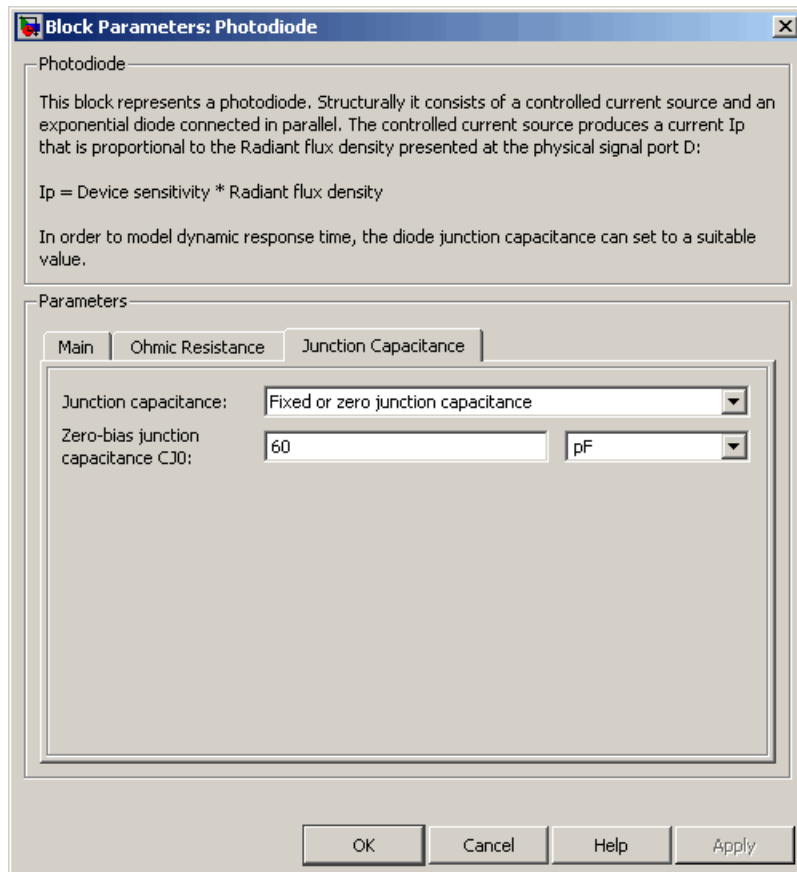

Junction capacitance

Select one of the following options for modeling the junction capacitance:

- Fixed or zero junction capacitance — Model the junction capacitance as a fixed value.

- Use C-V curve data points — Specify measured data at three points on the diode C-V curve.
- Use parameters CJO, VJ, M & FC — Specify zero-bias junction capacitance, junction potential, grading coefficient, and forward-bias depletion capacitance coefficient.

Zero-bias junction capacitance CJO

The value of the capacitance placed in parallel with the exponential diode term. This parameter is only visible when you select Fixed or zero junction capacitance or Use parameters CJO, VJ, M & FC for the **Junction capacitance** parameter. The default value is 60 pF. When you select Fixed or zero junction capacitance for the **Junction capacitance** parameter, a value of zero omits junction capacitance.

Reverse bias voltages [VR1 VR2 VR3]

A vector of the reverse bias voltage values at the three points on the diode C-V curve that the block uses to calculate *CJO*, *VJ*, and *M*. This parameter is only visible when you select Use C-V curve data points for the **Junction capacitance** parameter. The default value is [0.1 10 100] V.

Corresponding capacitances [C1 C2 C3]

A vector of the capacitance values at the three points on the diode C-V curve that the block uses to calculate *CJO*, *VJ*, and *M*. This parameter is only visible when you select Use C-V curve data points for the **Junction capacitance** parameter. The default value is [45 30 6] pF.

Junction potential VJ

The junction potential. This parameter is only visible when you select Use parameters CJO, VJ, M & FC for the **Junction capacitance** parameter. The default value is 1 V.

Grading coefficient M

The grading coefficient. This parameter is only visible when you select Use parameters CJO, VJ, M & FC for the **Junction capacitance** parameter. The default value is 0.5.

Capacitance coefficient FC

Fitting coefficient that quantifies the decrease of the depletion capacitance with applied voltage. This parameter is only visible when you select Use C-V curve data points or Use parameters CJO, VJ, M & FC for the **Junction capacitance** parameter. The default value is 0.5.

Ports

The block has the following ports:

D

Physical port representing incident flux.

+

Electrical conserving port associated with the diode positive terminal.

-

Electrical conserving port associated with the diode negative terminal.

References

[1] MH. Ahmed and P.J. Spreadbury. *Analogue and digital electronics for engineers*. 2nd Edition, Cambridge University Press, 1984.

[2] G. Massobrio and P. Antognetti. *Semiconductor Device Modeling with SPICE*. 2nd Edition, McGraw-Hill, 1993.

See Also

Diode, Light-Emitting Diode, Optocoupler

Piezo Linear Motor

Purpose Model force-speed characteristics of linear piezoelectric traveling wave motor

Library Actuators & Drivers

Description

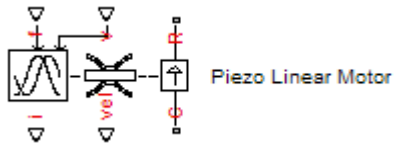

The Piezo Linear Motor block represents the force-speed characteristics of a linear piezoelectric traveling wave motor. The block represents the force-speed relationship of the motor at a level that is suitable for system-level modeling. To simulate the motor, the block uses the following models:

- “Mass and Friction Model for Unpowered Motor” on page 2-324
- “Resonant Circuit Model for Powered Motor” on page 2-325

Mass and Friction Model for Unpowered Motor

The motor is unpowered when the physical signal input v is zero. This corresponds to applying zero RMS volts to the motor. In this scenario, the block models the motor using the following elements:

- An mass whose value is the **Plunger mass** parameter value.
- A friction whose characteristics you specify using the parameter values in the **Motor-Off Friction** tab.

The block uses a Simscape Translational Friction block to model the friction component. For detailed information about the friction model, see the Translational Friction block reference page.

Resonant Circuit Model for Powered Motor

When the motor is active, Piezo Linear Motor block represents the motor characteristics using the following equivalent circuit model.

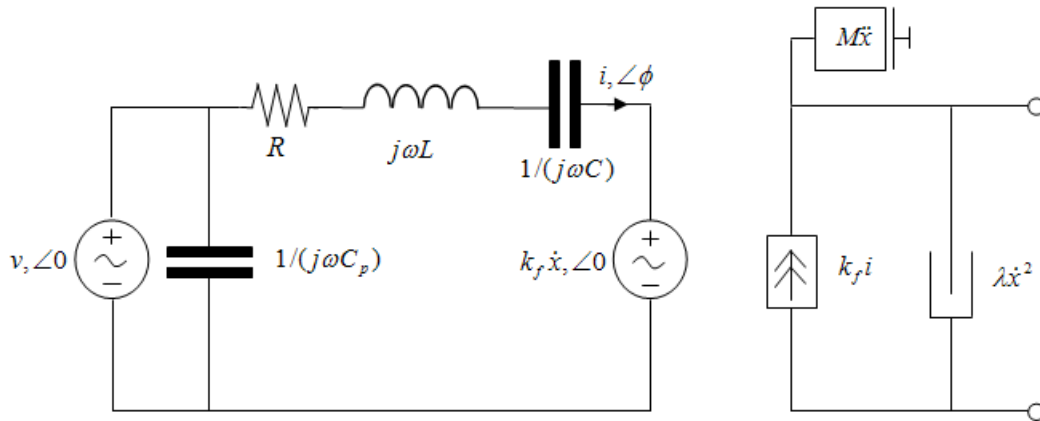

In the preceding figure:

- The AC voltage source represents the block's physical signal input of frequency f and magnitude v .
- The resistor R provides the main electrical and mechanical damping term.
- The inductor L represents the rotor vibration inertia.
- The capacitor C represents the piezo crystal stiffness.
- The capacitor C_p represents the phase capacitance. This is the electrical capacitance associated with each of the two motor phases.
- The force constant k_f relates the RMS current i to the resulting mechanical force.
- The quadratic mechanical damping term, $\lambda \dot{x}^2$, shapes the force-speed curve predominantly at speeds close to maximum RPM. \dot{x} is the linear speed.

Piezo Linear Motor

- The term $M\dot{x}$ represents the plunger inertia.

At model initialization, the block calculates the model parameters R , L , C , k_t and λ to ensure that the steady-state force-speed curve matches the values for the following user-specified parameters:

- **Rated force**
- **Rated speed**
- **No-load maximum speed**
- **Maximum (stall) force**

These parameter values are defined for the **Rated RMS voltage** and **Motor natural frequency** (or rated frequency) parameter values.

The quadratic mechanical damping term produces a quadratic force-speed curve. Piezoelectric motors force-speed curves can typically be approximated more accurately using a quadratic function than a linear one because the force-speed gradient becomes steeper as the motor approaches the maximum speed.

If the plunger mass M is not specified on the datasheet, you can select a value that provides a good match to the quoted response time. The response time is often defined as the time for the rotor to reach maximum speed when starting from rest, under no-load conditions.

The quality factor that you specify using the **Resonance quality factor** parameter relates to the equivalent circuit model parameters as follows:

$$Q = \frac{1}{R} \sqrt{\frac{L}{C}}$$

This term is not usually provided on a datasheet. You can calculate its value by matching the sensitivity of force to driving frequency.

To reverse the motor direction of operation, make the physical signal input v negative.

Basic Assumptions and Limitations

The block has the following limitations:

- When the motor is powered, the model is valid only between zero and maximum speed, for the following reasons:
 - Datasheets do not provide information for operation outside of normal range.
 - Piezoelectric motors are not designed to operate in the powered braking and generating regions.

The block behaves as follows outside the valid operating region:

- Below zero speed, the model maintains a constant force with a zero speed value. The zero speed value is the **Maximum (stall) force** parameter value if the RMS input voltage equals the **Rated RMS voltage** parameter value, and the frequency input equals the **Motor natural frequency** parameter value.
- Above maximum speed, the model produces the negative force predicted by the equivalent circuit model, but limits the absolute value of the force to the zero-speed maximum force.
- The force-speed characteristics are most representative when operating the model close to the rated voltage and resonant frequency.

Piezo Linear Motor

Dialog Box and Parameters

Electrical Force Tab

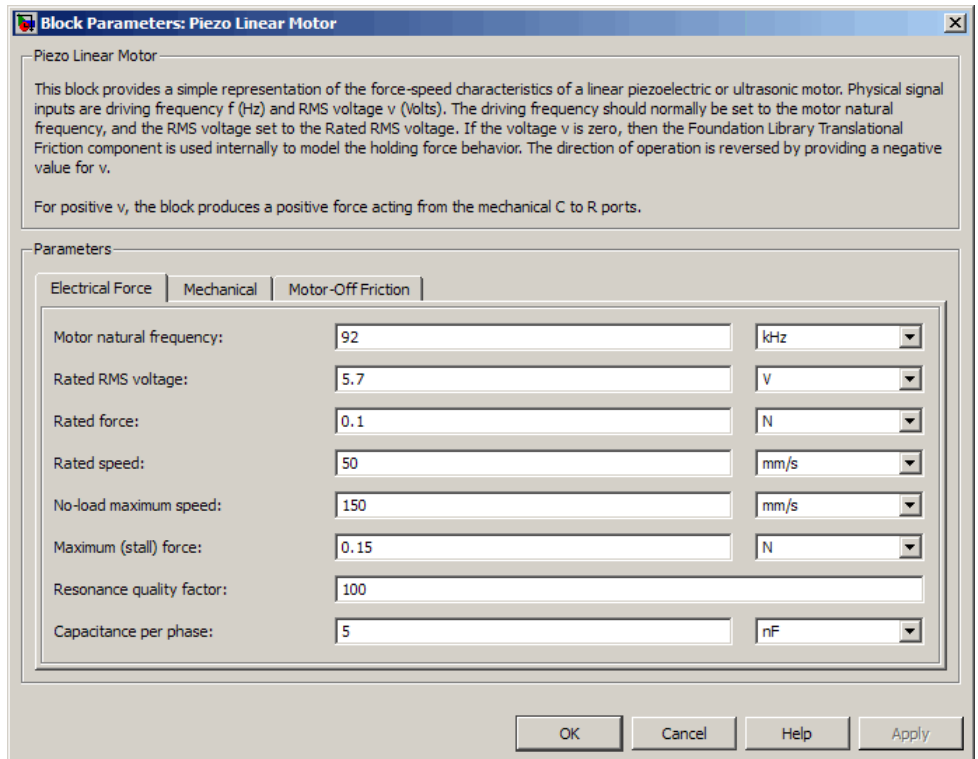

Block Parameters: Piezo Linear Motor

Piezo Linear Motor

This block provides a simple representation of the force-speed characteristics of a linear piezoelectric or ultrasonic motor. Physical signal inputs are driving frequency f (Hz) and RMS voltage v (Volts). The driving frequency should normally be set to the motor natural frequency, and the RMS voltage set to the Rated RMS voltage. If the voltage v is zero, then the Foundation Library Translational Friction component is used internally to model the holding force behavior. The direction of operation is reversed by providing a negative value for v .

For positive v , the block produces a positive force acting from the mechanical C to R ports.

Parameters

Electrical Force | Mechanical | Motor-Off Friction

Motor natural frequency:	92	kHz
Rated RMS voltage:	5.7	V
Rated force:	0.1	N
Rated speed:	50	mm/s
No-load maximum speed:	150	mm/s
Maximum (stall) force:	0.15	N
Resonance quality factor:	100	
Capacitance per phase:	5	nF

OK Cancel Help Apply

Motor natural frequency

Frequency at which the piezoelectric crystal naturally resonates. For most applications, set the input signal at port f to this frequency. To slow down the motor, for example in a closed-loop speed control, use a frequency slightly less than the motor natural frequency. The default value is 92 kHz.

Rated RMS voltage

Voltage at which the motor is designed to operate. The default value is 5.7 V.

Rated force

Force the motor delivers at the rated RMS voltage. The default value is 0.1 N.

Rated speed

Motor speed when the motor drives a load at the rated force. The default value is 50 mm/s.

No-load maximum speed

Motor speed when driving no load and powered at the rated voltage and driving frequency. The default value is 150 mm/s.

Maximum (stall) force

Maximum force the motor delivers when actively driving a load and powered at the rated voltage and frequency. The default value is 0.15 N.

Note The **Holding force** parameter value, the load force the motor holds when stationary, may be greater than the **Maximum (stall) force** parameter value.

Resonance quality factor

Quality factor Q that specifies how force varies as a function of driving frequency. Increasing the quality factor results in a much more rapid decrease in force as driving frequency is moved away from the natural frequency. The default value is 100.

Capacitance per phase

Electrical capacitance associated with each of the two motor phases. The default value is 5 nF.

Piezo Linear Motor

Mechanical Tab

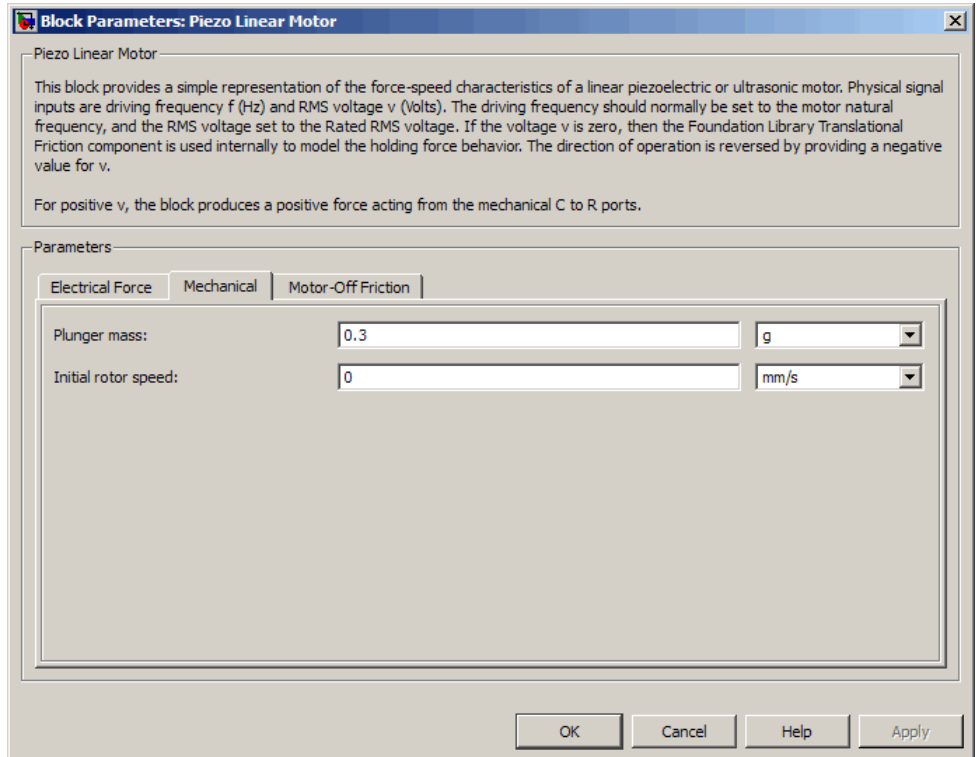

Plunger mass

Mass of the moving part of the motor. The default value is 0.3 g.

Initial rotor speed

Rotor speed at the start of the simulation. The default value is 0 mm/s.

Motor-Off Friction Tab

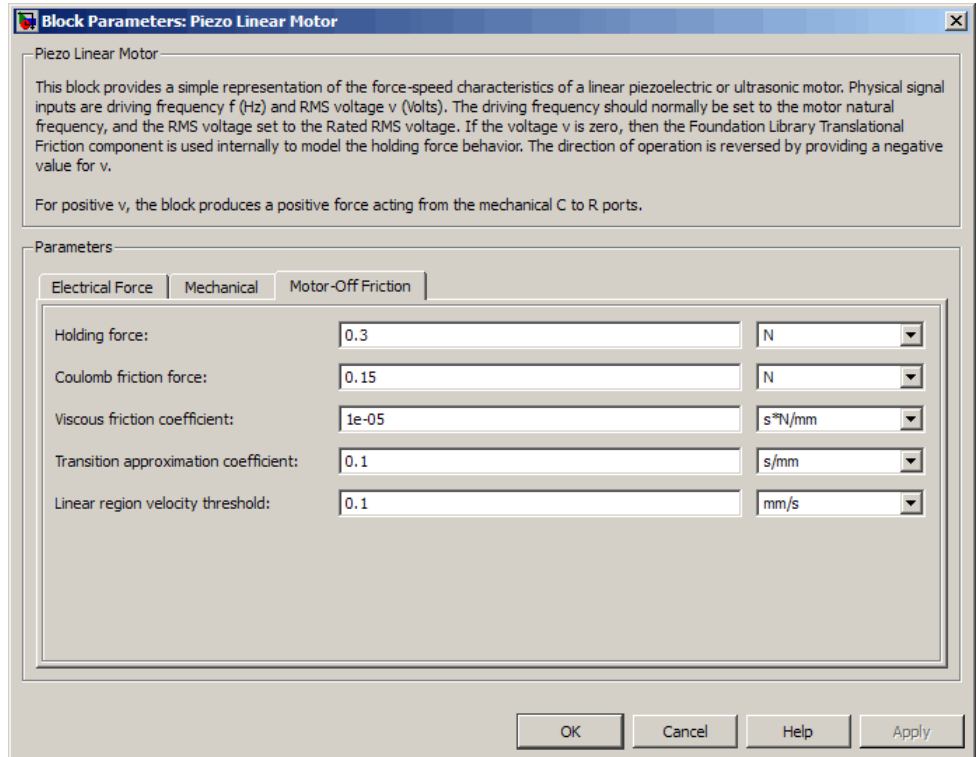

Holding force

The sum of the Coulomb and the static frictions. It must be greater than or equal to the **Coulomb friction force** parameter value. The default value is 0.3 N.

Coulomb friction force

The friction that opposes rotation with a constant force at any velocity. The default value is 0.15 N.

Piezo Linear Motor

Viscous friction coefficient

Proportionality coefficient between the friction force and the relative velocity. The parameter value must be greater than or equal to zero. The default value is $1e-05$ s*N/mm.

Transition approximation coefficient

The parameter sets the coefficient value that is used to approximate the transition between the static and the Coulomb frictions. For detailed information about the coefficient, c_v , see the Simscape Translational Friction block reference page. The default value is 0.1 s/mm.

Linear region velocity threshold

The parameter sets the small vicinity near zero velocity, within which friction force is considered to be linearly proportional to the relative velocity. The MathWorks™ recommends that you use values between $1e-6$ and $1e-4$ mm/s. The default value is 0.1 mm/s.

Ports

The block has the following ports:

f	Physical signal input value specifying the motor driving frequency in Hz.
v	Physical signal input magnitude specifying the RMS supply voltage, and sign specifying the direction of rotation. If v is positive, then a positive force acts from port C to port R.
i	Physical signal output value that is the RMS phase current.
vel	Physical signal output value that is the linear speed of the rotor.
C	Mechanical translational conserving port.

R

Mechanical translational conserving port.

Piezo Rotary Motor

Purpose

Model torque-speed characteristics of rotary piezoelectric traveling wave motor

Library

Actuators & Drivers

Description

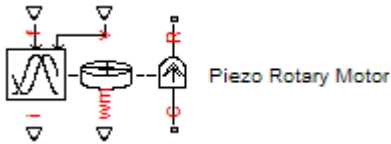

The Piezo Rotary Motor block represents the torque-speed characteristics of a piezoelectric traveling wave motor. The block represents the torque-speed relationship of the motor at a level that is suitable for system-level modeling. To simulate the motor, the block uses the following models:

- “Inertia and Friction Model for Unpowered Motor” on page 2-334
- “Resonant Circuit Model for Powered Motor” on page 2-335

Inertia and Friction Model for Unpowered Motor

The motor is unpowered when the physical signal input v is zero. This corresponds to applying zero RMS volts to the motor. In this scenario, the block models the motor using the following elements:

- An inertia whose value is the **Rotor inertia** parameter value.
- A friction whose characteristics are determined by the parameter values in the **Motor-Off Friction** tab.

The block uses a Simscape Rotational Friction block to model the friction component. For detailed information about the friction model, see the Rotational Friction block reference page.

Resonant Circuit Model for Powered Motor

When the motor is active, Piezo Rotary Motor block represents the motor characteristics using the following equivalent circuit model.

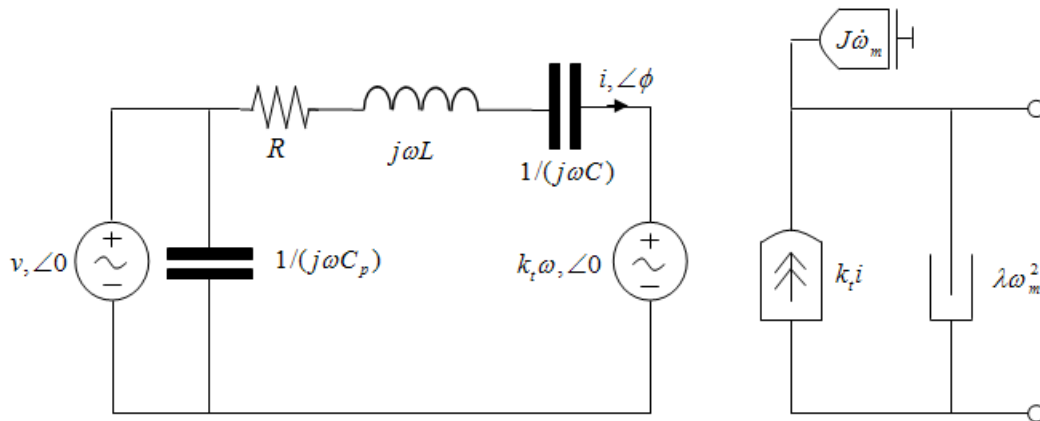

In the preceding figure:

- The AC voltage source represents the block's physical signal input of frequency f and magnitude v .
- The resistor R provides the main electrical and mechanical damping term.
- The inductor L represents the rotor vibration inertia.
- The capacitor C represents the piezo crystal stiffness.
- The capacitor C_p represents the phase capacitance. This is the electrical capacitance associated with each of the two motor phases.
- The torque constant k_t relates the RMS current i to the resulting mechanical torque.
- The quadratic mechanical damping term, $\lambda \omega_m^2$, shapes the torque-speed curve predominantly at speeds close to maximum RPM. ω_m is the mechanical rotational speed.

Piezo Rotary Motor

- The term $J\dot{\omega}_m$ represents the rotor inertia.

At model initialization, the block calculates the model parameters R , L , C , k_t and λ to ensure that the steady-state torque-speed curve matches the values of the following user-specified parameter values:

- **Rated torque**
- **Rated rotational speed**
- **No-load maximum rotational speed**
- **Maximum torque**

These parameter values are defined for the **Rated RMS voltage** and **Motor natural frequency** (or rated frequency) parameter values.

The quadratic mechanical damping term produces a quadratic torque-speed curve. Piezoelectric motors torque-speed curves can typically be approximated more accurately using a quadratic function than a linear one because the torque-speed gradient becomes steeper as the motor approaches the maximum speed.

If the rotor inertia J is not specified on the datasheet, you can select a value that provides a good match to the quoted response time. The response time is often defined as the time for the rotor to reach maximum speed when starting from rest, under no-load conditions.

The quality factor that you specify using the **Resonance quality factor** parameter relates to the equivalent circuit model parameters as follows:

$$Q = \frac{1}{R} \sqrt{\frac{L}{C}}$$

This term is not usually provided on a datasheet. You can calculate its value by matching the sensitivity of torque to driving frequency.

To reverse the motor direction of operation, make the physical signal input v negative.

Basic Assumptions and Limitations

The block has the following limitations:

- When the motor is powered, the model is valid only between zero and maximum speed, for the following reasons:
 - Datasheets do not provide information for operation outside of normal range.
 - Piezoelectric motors are not designed to operate in the powered braking and generating regions.

The block behaves as follows outside the valid operating region:

- Below zero speed, the model maintains a constant torque that is the zero rpm torque value. The zero rpm torque value is the **Maximum torque** parameter value if the RMS input voltage equals the **Rated RMS voltage** parameter value, and the frequency input equals the **Motor natural frequency** parameter value.
- Above maximum speed, the model produces the negative torque predicted by the equivalent circuit model, but limits the absolute value of the torque to the zero-speed maximum torque.
- The torque-speed characteristics are most representative when operating the model close to the rated voltage and resonant frequency.

Piezo Rotary Motor

Dialog Box and Parameters

Electrical Torque Tab

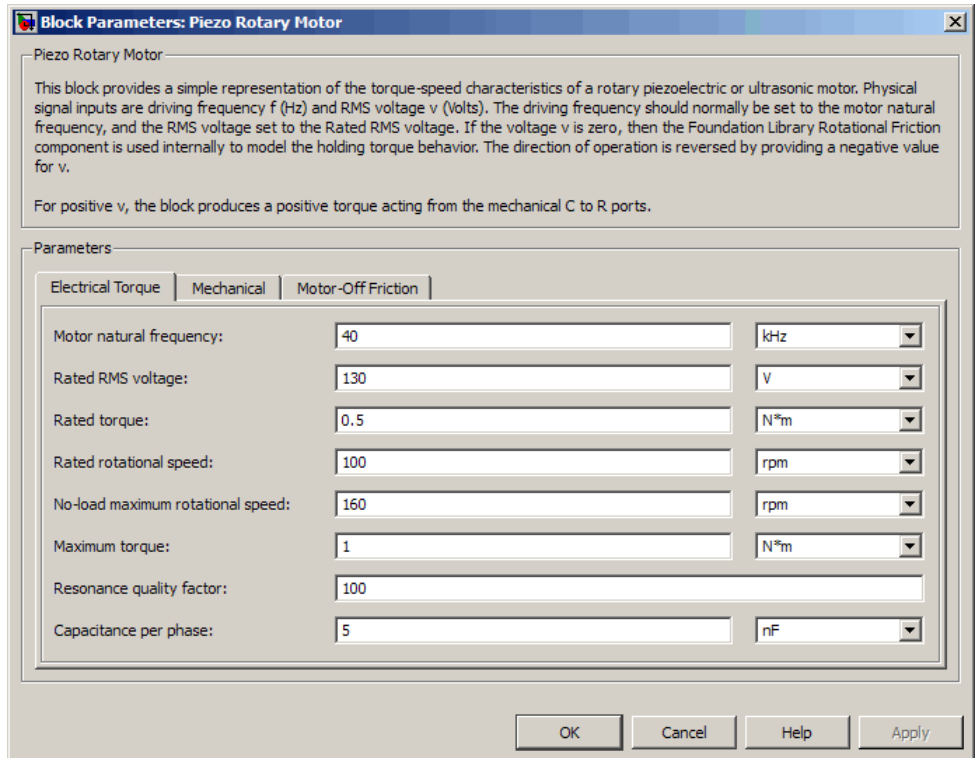

Block Parameters: Piezo Rotary Motor

Piezo Rotary Motor

This block provides a simple representation of the torque-speed characteristics of a rotary piezoelectric or ultrasonic motor. Physical signal inputs are driving frequency f (Hz) and RMS voltage v (Volts). The driving frequency should normally be set to the motor natural frequency, and the RMS voltage set to the Rated RMS voltage. If the voltage v is zero, then the Foundation Library Rotational Friction component is used internally to model the holding torque behavior. The direction of operation is reversed by providing a negative value for v .

For positive v , the block produces a positive torque acting from the mechanical C to R ports.

Parameters

Electrical Torque | Mechanical | Motor-Off Friction

Motor natural frequency:	40	kHz
Rated RMS voltage:	130	V
Rated torque:	0.5	N*m
Rated rotational speed:	100	rpm
No-load maximum rotational speed:	160	rpm
Maximum torque:	1	N*m
Resonance quality factor:	100	
Capacitance per phase:	5	nF

OK Cancel Help Apply

Motor natural frequency

Frequency at which the piezoelectric crystal naturally resonates. For most applications, set the input signal at port f to this frequency. To slow down the motor, for example in a closed-loop speed control, use a frequency slightly less than the motor natural frequency. The default value is 40 kHz.

Rated RMS voltage

Voltage at which the motor is designed to operate. The default value is 130 V.

Rated torque

Torque the motor delivers at the rated RMS voltage. The default value is 0.5 N*m.

Rated rotational speed

Motor speed when the motor drives a load at the rated torque. The default value is 100 rpm.

No-load maximum rotational speed

Motor rotational speed when driving no load and powered at the rated voltage and driving frequency. The default value is 160 rpm.

Maximum torque

Maximum torque that the motor delivers when actively driving a load and powered at the rated voltage and frequency. The default value is 1 N*m.

Note The **Holding torque** parameter value, the load torque the motor holds when stationary, may be greater than the **Maximum torque** parameter value.

Resonance quality factor

Quality factor Q that specifies how torque varies as a function of driving frequency. Increasing the quality factor results in a much more rapid decrease in torque as driving frequency is moved away from the natural frequency. The default value is 100.

Capacitance per phase

Electrical capacitance associated with each of the two motor phases. The default value is 5 nF.

Piezo Rotary Motor

Mechanical Tab

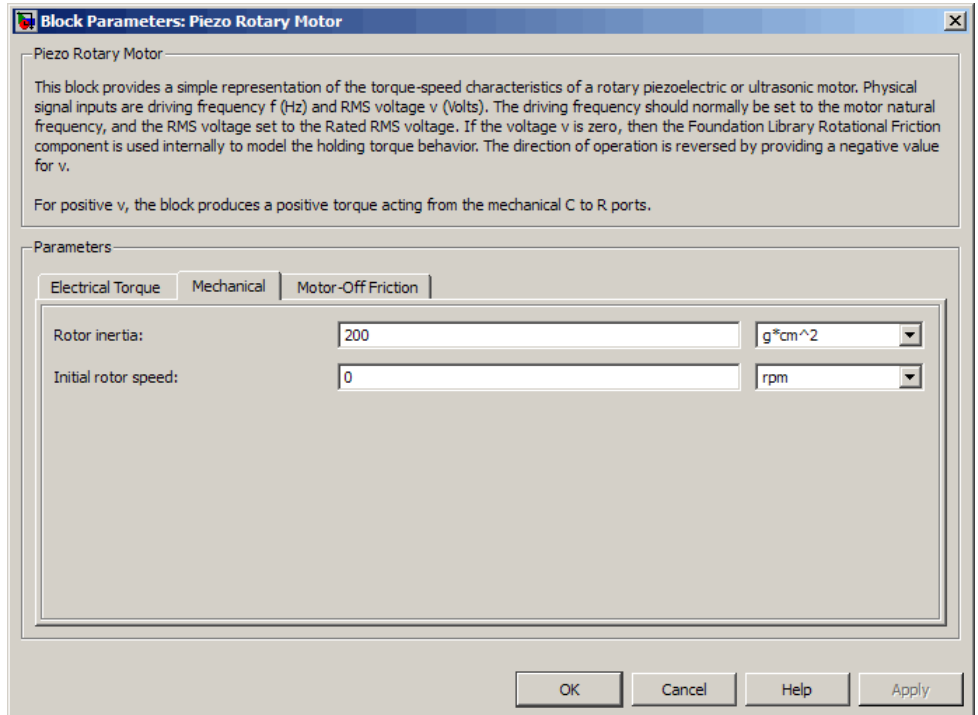

Rotor inertia

Rotor resistance to change in motor motion. The default value is 200 g*cm^2 .

Initial rotor speed

Rotor speed at the start of the simulation. The default value is 0 rpm .

Motor-Off Friction Tab

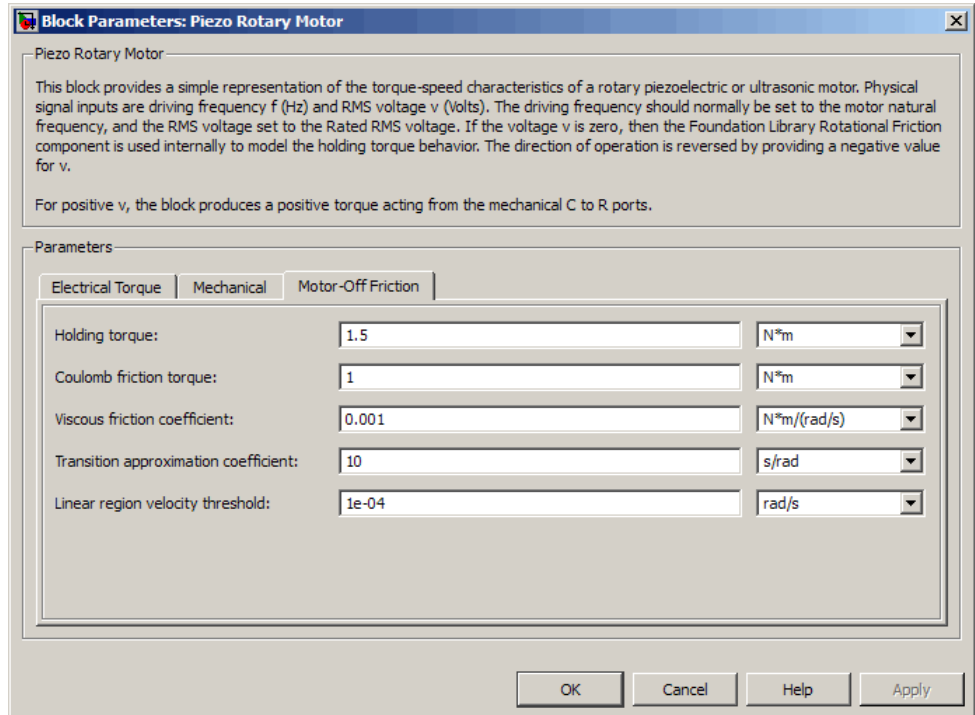

Holding torque

The sum of the Coulomb and the static frictions. It must be greater than or equal to the **Coulomb friction torque** parameter value. The default value is 1.5 N*m.

Coulomb friction torque

The friction that opposes rotation with a constant torque at any velocity. The default value is 1 N*m.

Piezo Rotary Motor

Viscous friction coefficient

Proportionality coefficient between the friction torque and the relative angular velocity. The parameter value must be greater than or equal to zero. The default value is 0.001 N*m/(rad*s).

Transition approximation coefficient

The parameter sets the coefficient value that is used to approximate the transition between the static and the Coulomb frictions. For detailed information about the coefficient, c_v , see the Simscape Rotational Friction block reference. The default value is 10 s/rad.

Linear region velocity threshold

The parameter sets the small vicinity near zero velocity, within which friction torque is considered to be linearly proportional to the relative velocity. The MathWorks recommends that you use values in the range between 1e-5 and 1e-3 rad/s. The default value is 1e-04 rad/s.

Ports

The block has the following ports:

f	Physical signal input value specifying the motor driving frequency in Hz.
v	Physical signal input magnitude specifying the RMS supply voltage, and sign specifying the direction of rotation. If v is positive, then a positive torque acts from port C to port R.
i	Physical signal output value that is the RMS phase current.
wm	Physical signal output value that is the rotational speed of the rotor.
C	Mechanical rotational conserving port.

R

Mechanical rotational conserving port.

Piezo Stack

Purpose

Model electrical and force characteristics of piezoelectric stacked actuator

Library

Actuators & Drivers

Description

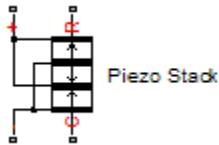

The Piezo Stack block represents the electrical and force characteristics of a piezoelectric stacked actuator using the following equations:

$$S = s^E T + d^T E$$

$$D = dT + \varepsilon^T E$$

where

- S is the strain tensor.
- T is the stress tensor.
- E is the electric field vector.
- D is the electric displacement vector.
- s^E is the elastic compliance matrix when subjected to a constant electric field.
- d is the piezoelectric constant matrix.
- ε^T is the permittivity measured at a constant stress.

Note The block models one-dimensional lumped parameter behavior, so S , T , E and D are all scalar values.

You can specify the block parameters that determine static force using either datasheet parameters or material properties, as determined by the value of the **Parameterization** parameter on the **Static Force** tab of the block dialog box.

The **Dynamic Forces** tab of the block dialog box lets you include optional effective mass and mechanical damping effects.

- If you specify a nonzero value for the **Effective mass** parameter or a finite value for the **Resonant frequency at constant field** parameter, the block attaches a lumped mass to the mechanical R port. When you specify a finite resonant frequency, the block calculates the effective mass to achieve the correct resonant frequency.
- If you specify a nonzero value for the **Damping** parameter or a finite value for the **Mechanical quality factor** parameter, the block adds a damping term across the R and C mechanical ports. When you specify a mechanical quality factor, Q_m , the block calculates the damping from this parameter value as \sqrt{Mk}/Q_m , where k is the short-circuit device stiffness, or equivalently the stiffness at constant field.

A positive voltage across the electrical + to – ports creates a positive displacement acting from the mechanical C to R ports.

Basic Assumptions and Limitations

The model does not include hysteresis effects.

Piezo Stack

Dialog Box and Parameters

Static Force Tab

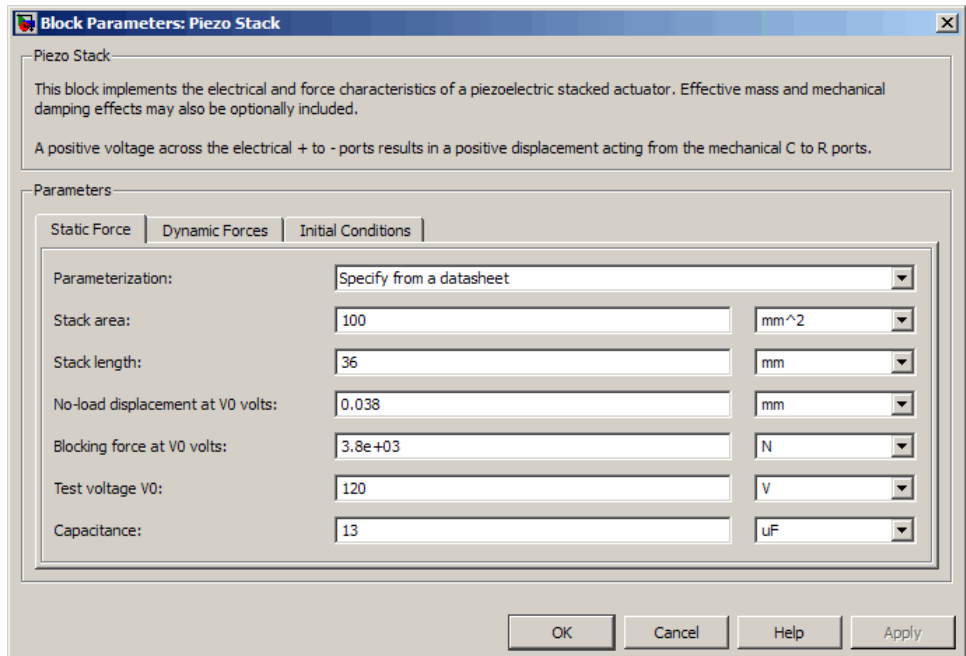

Parameterization

Select one of the following methods for static force parameterization:

- Specify from a datasheet — Provide datasheet parameters that the block converts to static force values. This is the default method.
- Specify material properties — Provide material properties that the block converts to static force values.

Stack area

Cross-sectional area of the stack. The default value is 100 mm².

Stack length

Stack length when no load and no electrical potential are applied. This parameter is only visible when you select **Specify** from a datasheet for the **Parameterization** parameter. The default value is 36 mm.

No-load displacement at V0 volts

Unconstrained displacement of the stack when a voltage of V0 volts is applied. This parameter is only visible when you select **Specify** from a datasheet for the **Parameterization** parameter. The default value is 0.038 mm.

Blocking force at V0 volts

Force the stack produces when a voltage of V0 volts is applied and the stack is physically prevented from expanding. This parameter is only visible when you select **Specify** from a datasheet for the **Parameterization** parameter. The default value is 3.8e+03 N.

Test voltage V0

Voltage used to determine the no-load displacement and blocking force. This parameter is only visible when you select **Specify** from a datasheet for the **Parameterization** parameter. The default value is 120 V.

Capacitance

This parameter is only visible when you select **Specify** from a datasheet for the **Parameterization** parameter. The default value is 13 uF.

Piezo layer thickness

Thickness of each layer in the piezo stack. This parameter is only visible when you select **Specify material properties** for the **Parameterization** parameter. The default value is 0.3 mm.

Number of layers

Number of layers in the piezo stack. This parameter is only visible when you select **Specify material properties** for the **Parameterization** parameter. The default value is 50.

Piezoelectric charge constant

Mechanical strain per unit electric field applied. This parameter is only visible when you select **Specify material properties** for the **Parameterization** parameter. The default value is $5e-10$ m/V.

Dielectric constant

Permittivity or dielectric displacement per unit electric field measured at constant stress. This parameter is only visible when you select **Specify material properties** for the **Parameterization** parameter. The default value is $2.124e-08$ F/m.

Elastic compliance

Strain produced in a piezoelectric material per unit of stress applied. This parameter is only visible when you select **Specify material properties** for the **Parameterization** parameter. The default value is $1.9e-11$ m²/N.

Dynamic Forces Tab

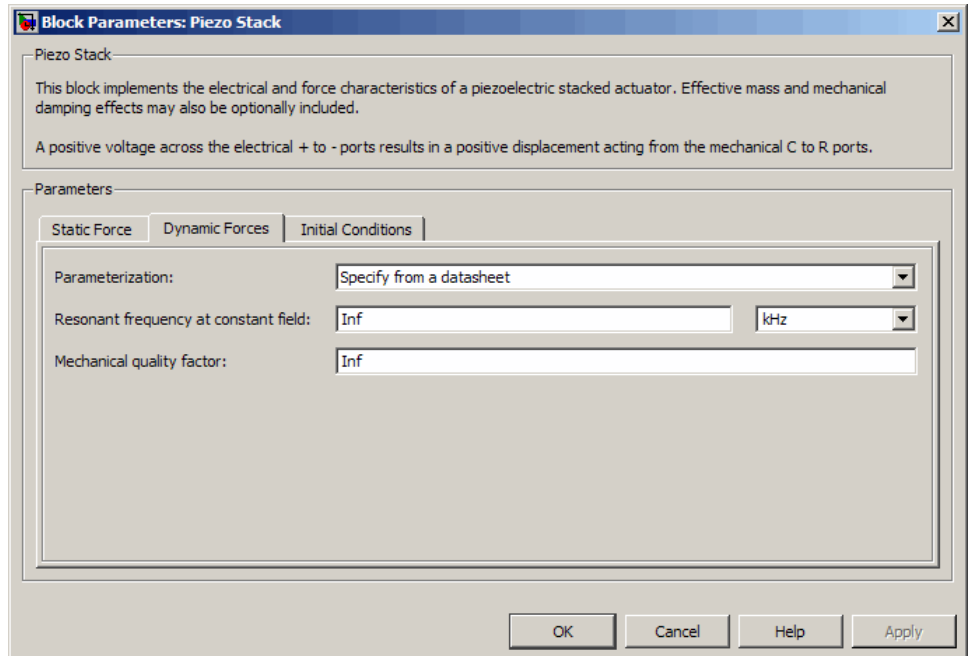

Parameterization

Select one of the following methods for dynamic force parameterization:

- **Specify from a datasheet** — Provide datasheet parameters that the block converts to dynamic force values. This is the default method.
- **Specify material properties** — Provide material properties that the block converts to dynamic force values.

Resonant frequency at constant field

Frequency at which the actuator naturally resonates if mechanically perturbed with the electrical ports shorted. This

parameter is only visible when you select **Specify** from a datasheet for the **Parameterization** parameter. The default value is Inf kHz.

Mechanical quality factor

Factor that affects the damping across the R and C mechanical ports. This parameter is only visible when you select **Specify** from a datasheet for the **Parameterization** parameter. The default value is Inf.

Damping

Translational damping term. This parameter is only visible when you select **Specify material properties** for the **Parameterization** parameter. The default value is 0 N/(m/s).

Effective mass

Mass that approximates the distributed dynamics of the device and causes the stack to resonate at the correct frequency when attached to the mechanical R port. This mass is usually about one third of the actual stack mass. This parameter is only visible when you select **Specify material properties** for the **Parameterization** parameter. The default value is 0 g.

Initial Conditions Tab

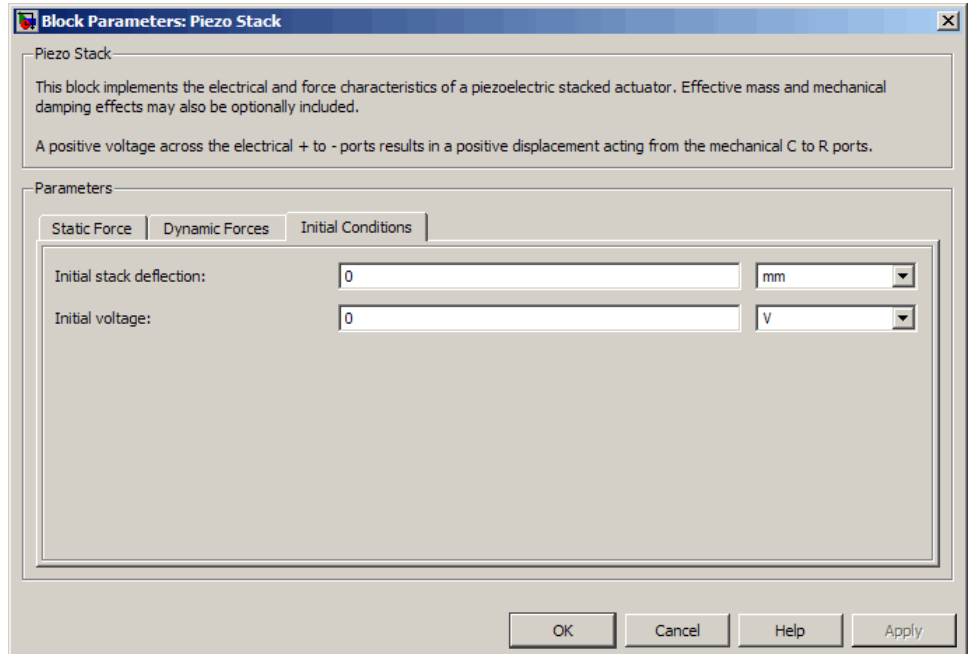

Initial stack deflection

Stack deflection at time zero. If you have an external Ideal Translational Motion Sensor block attached across the Piezo Stack block, you must use the same initial deflection parameter for both blocks. The default value is 0 mm.

Initial voltage

Stack voltage at time zero. The default value is 0 V.

Ports

The block has the following ports:

- + Positive electrical port.

Piezo Stack

- Negative electrical port.
- C Mechanical rotational conserving port.
- R Mechanical rotational conserving port.

Purpose Model SPICE-compatible P-Channel JFET

Library SPICE-Compatible Semiconductors

Description The PJFET block represents a SPICE-compatible P-channel JFET.



PJFET

The PJFET block model includes the following components:

- “Source-Gate Current-Voltage Model” on page 2-353
- “Drain-Gate Current-Voltage Model” on page 2-354
- “Source-Drain Current-Voltage Model” on page 2-355
- “Junction Charge Model” on page 2-356
- “Temperature Dependence” on page 2-358

Source-Gate Current-Voltage Model

The block provides the following relationship between the source-gate current I_{sg} and the source-gate voltage V_{sg} after adjusting the applicable model parameters for temperature.

Applicable Range of V_{sg} Values	Corresponding I_{sg} Equation
$V_{sg} > 80 * V_t$	$I_{sg} = IS * \left(\left(\frac{V_{sg}}{V_t} - 79 \right) e^{80} - 1 \right) + V_{sg} * G \text{ min}$
$80 * V_t \geq V_{sg}$	$I_{sg} = IS * \left(e^{V_{sg}/V_t} - 1 \right) + V_{sg} * G \text{ min}$

Where:

- I_S is the **Saturation current**, **IS** parameter value.
- $V_i = ND * k * T / q$
- ND is the **Emission coefficient**, **ND** parameter value.
- q is the elementary charge on an electron.
- k is the Boltzmann constant.
- T is the diode temperature:
 - If you select **Device temperature** for the **Model temperature dependence using** parameter, T is the sum of the **Circuit temperature** value plus the **Offset local circuit temperature**, **TOFFSET** parameter value. The **Circuit temperature** value comes from the SPICE Environment Parameters block, if one exists in the circuit. Otherwise, it comes from the default value for this block.
 - If you select **Fixed temperature** for the **Model temperature dependence using** parameter, T is the **Fixed circuit temperature**, **TFIXED** parameter value.
- $GMIN$ is the diode minimum conductance. By default, $GMIN$ matches the **Minimum conductance GMIN** parameter of the SPICE Environment Parameters block, whose default value is 1e-12. To change $GMIN$, add a SPICE Environment Parameters block to your model and set the **Minimum conductance GMIN** parameter to the desired value.

Drain-Gate Current-Voltage Model

The block provides the following relationship between the drain-gate current I_{dg} and the drain-gate voltage V_{dg} after adjusting the applicable model parameters for temperature.

Applicable Range of V_{dg} Values	Corresponding I_{dg} Equation
$V_{dg} > 80 * V_t$	$I_{dg} = IS * \left(\left(\frac{V_{dg}}{V_t} - 79 \right) e^{80} - 1 \right) + V_{dg} * G \text{ min}$
$80 * V_t \geq V_{dg}$	$I_{dg} = IS * \left(e^{V_{dg}/V_t} - 1 \right) + V_{dg} * G \text{ min}$

Source-Drain Current-Voltage Model

The block provides the following relationship between the source-drain current I_{sd} and the source-drain voltage V_{sd} in normal mode ($V_{sd} \geq 0$) after adjusting the applicable model parameters for temperature.

Applicable Range of V_{sg} and V_{dg} Values	Corresponding I_{sd} Equation
$V_{sg} - V_{to} \leq 0$	$I_{sd} = 0$
$0 < V_{sg} - V_{to} \leq V_{sd}$	$I_{sd} = -\beta * (V_{sg} - V_{to})^2 * (1 + \lambda * V_{sd})$
$0 < V_{sd} < V_{sg} - V_{to}$	$I_{sd} = \beta * V_{sd} * (2 * (V_{sg} - V_{to}) - V_{sd}) * (1 + \lambda * V_{sd})$

Where:

- V_{to} is the **Threshold voltage**, VTO parameter value.
- β is the **Transconductance**, BETA parameter value.
- λ is the **Channel modulation**, LAMBDA parameter value.

The block provides the following relationship between the source-drain current I_{sd} and the source-drain voltage V_{sd} in inverse mode ($V_{sd} < 0$) after adjusting the applicable model parameters for temperature.

Applicable Range of V_{sg} and V_{dg} Values	Corresponding I_{sd} Equation
$V_{dg} - V_{to} \leq 0$	$I_{sd} = 0$
$0 < V_{dg} - V_{to} \leq -V_{sd}$	$I_{sd} = \beta * (V_{dg} - V_{to})^2 * (1 - \lambda * V_{sd})$
$0 < -V_{sd} < V_{dg} - V_{to}$	$I_{sd} = \beta * V_{sd} * (2 * (V_{dg} - V_{to}) + V_{sd}) * (1 - \lambda * V_{sd})$

Junction Charge Model

The block provides the following relationship between the source-gate charge Q_{sg} and the source-gate voltage V_{sg} after adjusting the applicable model parameters for temperature.

Applicable Range of V_{sg} Values	Corresponding Q_{sg} Equation
$V_{sg} < FC * VJ$	$Q_{sg} = \frac{CGS * VJ * \left(1 - \left(1 - \frac{V_{sg}}{VJ} \right)^{1-MG} \right)}{1 - MG}$
$V_{sg} \geq FC * VJ$	$Q_{sg} = CGS * \left(F1 + \frac{F3 * (V_{sg} - FC * VJ) + \frac{MG * (V_{sg}^2 - (FC * VJ)^2)}{2 * VJ}}{F2} \right)$

Where:

- *FC* is the **Capacitance coefficient FC** parameter value.
- *VJ* is the **Junction potential VJ** parameter value.
- *CGS* is the **Zero-bias GS capacitance, CGS** parameter value.
- *MG* is the **Grading coefficient, MG** parameter value.

- $$F1 = \frac{VJ * (1 - (1 - FC)^{1-MG})}{1 - MG}$$

- $$F2 = (1 - FC)^{1+MG}$$

- $$F3 = 1 - FC * (1 + MG)$$

The block provides the following relationship between the drain-gate charge Q_{dg} and the drain-gate voltage V_{dg} after adjusting the applicable model parameters for temperature.

Applicable Range of V_{dg} Values	Corresponding Q_{dg} Equation
$V_{dg} < FC * VJ$	$Q_{dg} = \frac{CGD * VJ * \left(1 - \left(1 - \frac{V_{dg}}{VJ} \right)^{1-MG} \right)}{1 - MG}$
$V_{dg} \geq FC * VJ$	$Q_{dg} = CGD * \left(F1 + \frac{F3 * (V_{dg} - FC * VJ) + \frac{MG * (V_{dg}^2 - (FC * VJ)^2)}{2 * VJ}}{F2} \right)$

Where:

- CGD is the **Zero-bias GD capacitance**, CGD parameter value.

Temperature Dependence

Several transistor parameters depend on temperature. There are two ways to specify the transistor temperature:

- When you select `Device` temperature for the **Model temperature dependence using** parameter, the transistor temperature is

$$T = T_C + T_O$$

where:

- T_C is the **Circuit temperature** parameter value from the SPICE Environment Parameters block. If this block doesn't exist in the circuit, T_C is the default value of this parameter.
 - T_O is the **Offset local circuit temperature**, $TOFFSET$ parameter value.
- When you select `Fixed` temperature for the **Model temperature dependence using** parameter, the transistor temperature is the **Fixed circuit temperature**, $TFIXED$ parameter value.

The block provides the following relationship between the saturation current IS and the transistor temperature T :

$$IS(T) = IS * (T/T_{meas})^{\frac{XTI}{ND}} * e^{\left(\frac{T}{T_{meas}} - 1\right) * \frac{EG}{V_t}}$$

where:

- IS is the **Saturation current**, IS parameter value.
- T_{meas} is the **Parameter extraction temperature**, $TMEAS$ parameter value.
- XTI is the **Saturation current temperature exponent**, XTI parameter value.
- EG is the **Energy gap**, EG parameter value.

- $V_i = ND * k * T/q$
- ND is the **Emission coefficient**, **ND** parameter value.

The block provides the following relationship between the junction potential VJ and the transistor temperature T :

$$VJ(T) = VJ * \left(\frac{T}{T_{meas}} \right) - \frac{3 * k * T}{q} * \log \left(\frac{T}{T_{meas}} \right) - \left(\frac{T}{T_{meas}} \right) * EG_{T_{meas}} + EG_T$$

where:

- VJ is the **Junction potential VJ** parameter value.
- $EG_{T_{meas}} = 1.16eV - (7.02e - 4 * T_{meas}^2) / (T_{meas} + 1108)$
- $EG_T = 1.16eV - (7.02e - 4 * T^2) / (T + 1108)$

The block provides the following relationship between the gate-source junction capacitance CGS and the transistor temperature T :

$$CGS(T) = CGS * \left[1 + MG * \left(400e - 6 * (T - T_{meas}) - \frac{VJ(T) - VJ}{VJ} \right) \right]$$

where:

- CGS is the **Zero-bias GS capacitance**, **CGS** parameter value.

The block uses the $CGS(T)$ equation to calculate the gate-drain junction capacitance by substituting CGD (the **Zero-bias GD capacitance**, **CGD** parameter value) for CGS .

The block provides the following relationship between the forward and reverse beta and the transistor temperature T :

$$\beta(T) = \beta * \left(\frac{T}{T_{meas}} \right)$$

where β is the **Transconductance, BETA** parameter value.

Basic Assumptions and Limitations

The model is based on the following assumptions:

- The PJFET block does not support noise analysis.
- The PJFET block applies initial conditions across junction capacitors and not across the block ports.

**Dialog
Box and
Parameters**

Main Tab

Block Parameters: PJFET

PJFET

This model approximates a SPICE P-channel JFET. You specify both model card and instance parameters as instance parameters on this mask. The instance parameter OFF and noise model parameters KF and AF are not supported. Additional instance parameters are SCALE, TOFFSET, ND, MG, XTI and EG.

SCALE is the number of parallel JFET instances for this device. SCALE multiplies the output current and device charge directly. This differs from the AREA parameter, which multiplies the device parameters BETA, IS, CGS, CGD, and divides RS and RD.

You can set the JFET temperature to a fixed temperature or to the circuit temperature (from the Custom Electrical Environment block) plus TOFFSET. The parameters ND, MG, XTI and EG adjust temperature sensitive parameters.

The block lets you include or exclude capacitance modeling and initial conditions. The capacitance modeling uses the published temperature equations, which may yield a slightly different value than SPICE for capacitance. The initial conditions ICVDS and ICVGS are the voltages across the internal junctions, and are only effective when the corresponding junction capacitances are present.

Parameters

Main | Junction Capacitance | Temperature

Device area, AREA:	1	m ²
Number of parallel devices, SCALE:	1	
Threshold voltage, VTO:	-2	V
Transconductance, BETA:	1e-04	A/m ² /V ²
Channel modulation, LAMBDA:	0	1/V
Saturation current, IS:	1e-14	A/m ²
Emission coefficient, ND:	1	
Source resistance, RS:	0	m ² *Ohm
Drain resistance, RD:	0	m ² *Ohm

OK Cancel Help Apply

Device area, AREA

The transistor area. This value multiplies the **Transconductance, BETA**, **Zero-bias GS capacitance, CGS**, **Zero-bias GD capacitance, CGD**, and **Saturation current, IS** parameter values. It divides the **Source resistance, RS** and **Drain resistance, RD** parameter values. The default value is 1 m². The value must be greater than 0.

Number of parallel devices, SCALE

The number of parallel transistors the block represents. This value multiplies the output current and device charges. The default value is 1. The value must be greater than 0.

Threshold voltage, VTO

The gate-source voltage above which the transistor produces a nonzero drain current. The default value is -2 V.

Transconductance, BETA

The derivative of drain current with respect to gate voltage. The default value is 1e-04 A/m²/V². The value must be greater than or equal to 0.

Channel modulation, LAMBDA

The channel-length modulation. The default value is 0 1/V.

Saturation current, IS

The magnitude of the current that the ideal diode equation approaches asymptotically for very large reverse bias levels. The default value is 1e-14 A/m². The value must be greater than or equal to 0.

Emission coefficient, ND

The transistor emission coefficient or ideality factor. The default value is 1. The value must be greater than 0.

Source resistance, RS

The transistor source resistance. The default value is 0 m²*Ω. The value must be greater than or equal to 0.

Drain resistance, RD

The transistor drain resistance. The default value is 0 m²*Ω. The value must be greater than or equal to 0.

Junction Capacitance Tab

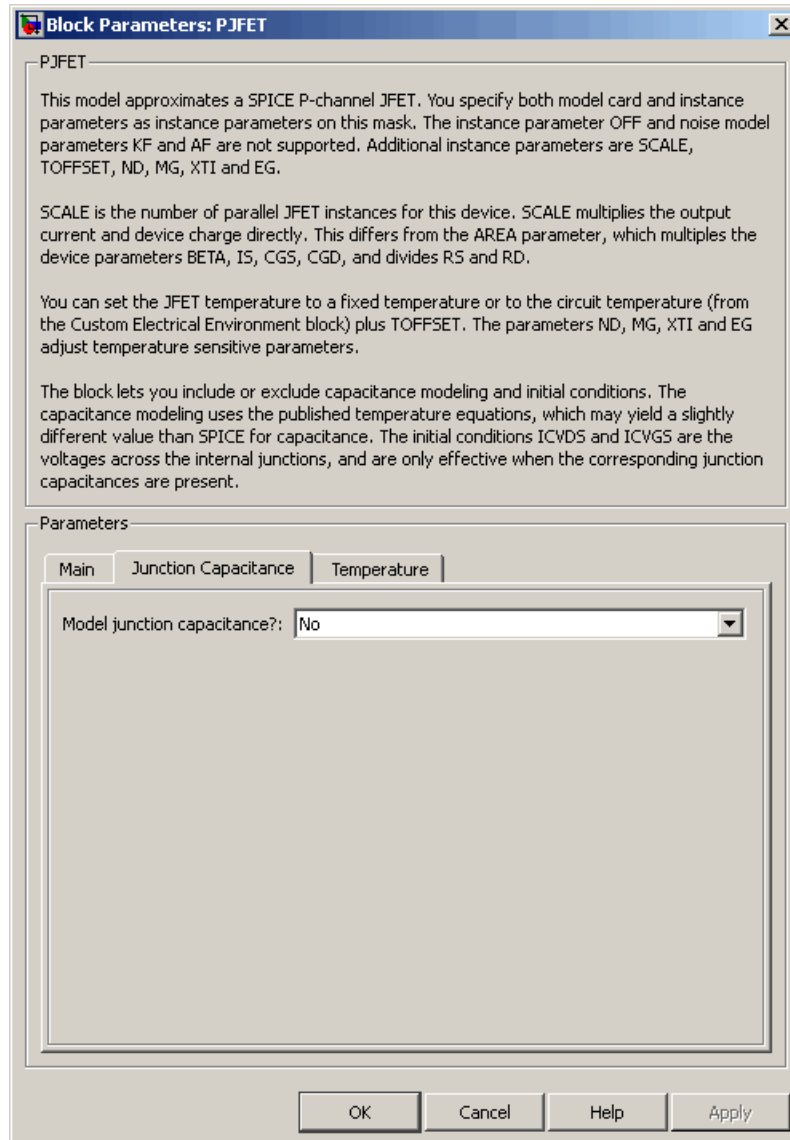

Model junction capacitance

Select one of the following options for modeling the junction capacitance:

- **No** — Do not include junction capacitance in the model. This is the default option.
- **Yes** — Specify zero-bias junction capacitance, junction potential, grading coefficient, forward-bias depletion capacitance coefficient, and transit time.

Zero-bias GS capacitance, CGS

The value of the capacitance placed between the gate and the source. This parameter is only visible when you select **Yes** for the **Model junction capacitance** parameter. The default value is 0 F/m². The value must be greater than or equal to 0.

Zero-bias GD capacitance, CGD

The value of the capacitance placed between the gate and the drain. This parameter is only visible when you select **Yes** for the **Model junction capacitance** parameter. The default value is 0 F/m². The value must be greater than or equal to 0.

Junction potential VJ

The junction potential. This parameter is only visible when you select **Yes** for the **Model junction capacitance** parameter. The default value is 1 V. The value must be greater than 0.01 V.

Grading coefficient, MG

The transistor grading coefficient. The default value is 0.5. The value must be greater than 0 and less than 0.9.

Capacitance coefficient FC

The fitting coefficient that quantifies the decrease of the depletion capacitance with applied voltage. This parameter is only visible when you select **Yes** for the **Model junction capacitance** parameter. The default value is 0.5. The value must be greater than or equal to 0 and less than or equal to 0.95.

Specify initial condition

Select one of the following options for specifying an initial condition:

- No — Do not specify an initial condition for the model. This is the default option.
- Yes — Specify the initial diode voltage.

Note The PJFET block applies the initial diode voltage across the junction capacitors and not across the ports.

Initial condition voltage ICVDS

Drain-source voltage at the start of the simulation. This parameter is only visible when you select **Yes** for the **Model junction capacitance** and **Yes** for the **Specify initial condition** parameter. The default value is 0 V.

Initial condition voltage ICVGS

Gate-source voltage at the start of the simulation. This parameter is only visible when you select **Yes** for the **Model junction capacitance** and **Yes** for the **Specify initial condition** parameter. The default value is 0 V.

Temperature Tab

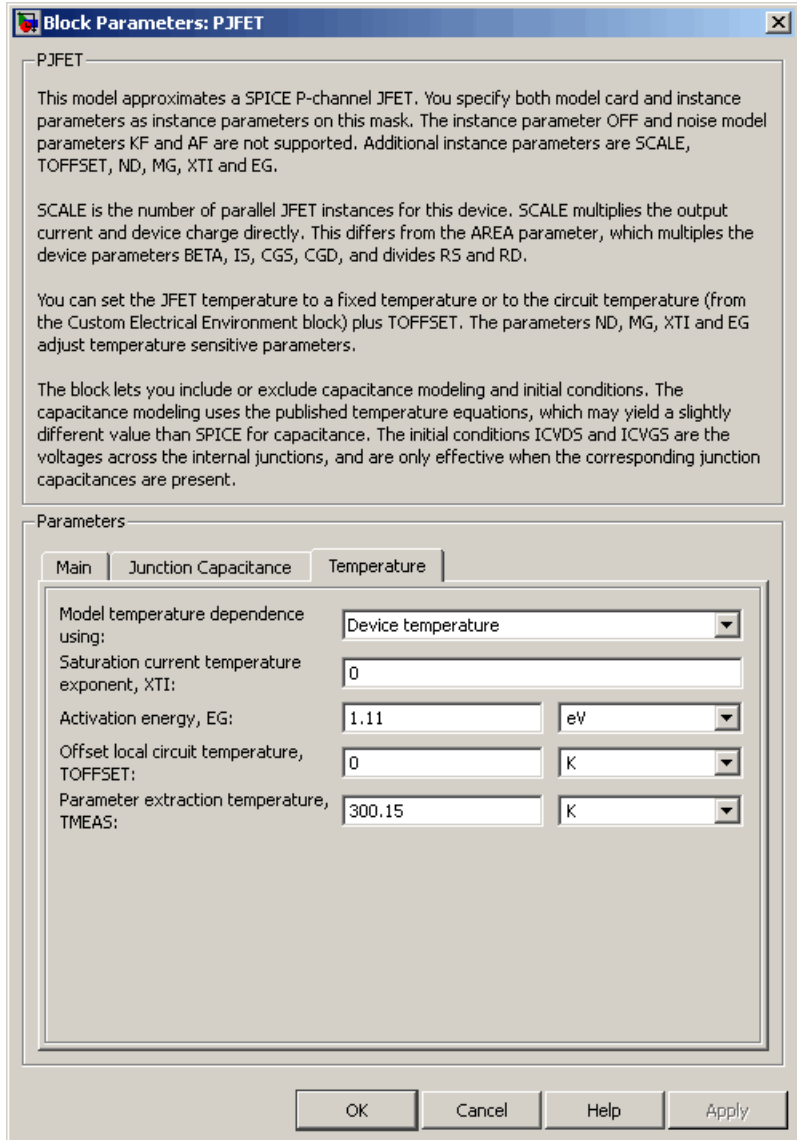

Model temperature dependence using

Select one of the following options for modeling the diode temperature dependence:

- **Device temperature** — Use the device temperature, which is the **Circuit temperature** value plus the **Offset local circuit temperature, TOFFSET** value. The **Circuit temperature** value comes from the SPICE Environment Parameters block, if one exists in the circuit. Otherwise, it comes from the default value for this block.
- **Fixed temperature** — Use a temperature that is independent of the circuit temperature to model temperature dependence.

Saturation current temperature exponent, XTI

The order of the exponential increase in the saturation current as temperature increases. The default value is 0. The value must be greater than or equal to 0.

Activation energy, EG

The energy gap that affects the increase in the saturation current as temperature increases. The default value is 1.11 eV. The value must be greater than 0.1 eV.

Offset local circuit temperature, TOFFSET

The amount by which the transistor temperature differs from the circuit temperature. This parameter is only visible when you select **Device temperature** for the **Model temperature dependence using** parameter. The default value is 0 K.

Fixed circuit temperature, TFIXED

The temperature at which to simulate the transistor. This parameter is only visible when you select **Fixed temperature** for the **Model temperature dependence using** parameter. The default value is 300.15 K. The value must be greater than 0.

Parameter extraction temperature, TMEAS

The temperature at which the transistor parameters were measured. The default value is 300.15 K. The value must be greater than 0.

Ports

The block has the following ports:

G

Electrical conserving port associated with the transistor gate terminal.

D

Electrical conserving port associated with the transistor drain terminal.

S

Electrical conserving port associated with the transistor source terminal.

References

[1] G. Massobrio and P. Antognetti. *Semiconductor Device Modeling with SPICE*. 2nd Edition, McGraw-Hill, 1993. Chapter 3.

See Also

NJFET, P-Channel JFET

Purpose Model SPICE-compatible P-Channel MOSFET

Library SPICE-Compatible Semiconductors

Description The PMOS block represents a SPICE-compatible P-channel MOSFET.

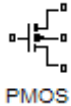

The PMOS block model includes the following components:

- “Resistance Calculations” on page 2-370
- “Bulk-Source Diode Model” on page 2-371
- “Bulk-Drain Diode Model” on page 2-372
- “Level 1 Drain Current Model” on page 2-373
- “Level 3 Drain Current Model” on page 2-376
- “Junction Charge Model” on page 2-382
- “Temperature Dependence” on page 2-387

Resistance Calculations

The following table shows how the PMOS block calculates the transistor drain resistance. The abbreviations in the table represent the values of the following block parameters:

- Drain resistance, RD
- Sheet resistance, RSH
- Number of drain squares, NRD

Drain resistance, RD Parameter	Sheet resistance, RSH Parameter	Drain Resistance
NaN	NaN	0
RD	NaN or RSH	RD
NaN	RSH	$RSH*NRD$

The following table shows how the PMOS block calculates the transistor source resistance. The abbreviations in the table represent the values of the following block parameters:

- Source resistance, RS
- Sheet resistance, RSH
- Number of source squares, NRS

Source resistance, RS Parameter	Sheet resistance, RSH Parameter	Source Resistance
NaN	NaN	0
RS	NaN or RSH	RS
NaN	RSH	RSH*NRS

Bulk-Source Diode Model

The block provides the following relationship between the bulk-source current I_{sb} and the bulk-source voltage V_{sb} after adjusting the applicable model parameters for temperature.

Applicable Range of V_{sb} Values	Corresponding I_{gs} Equation
$V_{sb} > 80 * V_{tn}$	$I_{sb} = IS_{sb} * \left(\left(\frac{V_{sb}}{V_m} - 79 \right) e^{80} - 1 \right) + V_{sb} * G \text{ min}$
$80V_{tn} \geq V_{sb}$	$I_{sb} = IS_{sb} * \left(e^{V_{sb}/V_m} - 1 \right) + V_{sb} * G \text{ min}$

Where:

- IS_{sb} is
 - The product of the **Bulk jct sat current density, JS** parameter value and the **Area of source, AS** parameter value if both these

parameter values and the **Area of drain, AD** parameter value are nonzero.

- The **Bulk saturation current, IS** parameter value, otherwise.
- $V_{in} = NkT/q$
- q is the elementary charge on an electron, 1.6021918e-19 C.
- N is the **Emission coefficient, ND** parameter value.
- k is the Boltzmann constant.
- T is the diode temperature:
 - If you select Device temperature for the **Model temperature dependence using** parameter, T is the sum of the **Circuit temperature** value plus the **Offset local circuit temperature, TOFFSET** parameter value. The **Circuit temperature** value comes from the SPICE Environment Parameters block, if one exists in the circuit. Otherwise, it comes from the default value for this block.
 - If you select Fixed temperature for the **Model temperature dependence using** parameter, T is the **Fixed circuit temperature, TFIXED** parameter value.
- $GMIN$ is the diode minimum conductance. By default, $GMIN$ matches the **Minimum conductance GMIN** parameter of the SPICE Environment Parameters block, whose default value is 1e-12. To change $GMIN$, add a SPICE Environment Parameters block to your model and set the **Minimum conductance GMIN** parameter to the desired value.

Bulk-Drain Diode Model

The block provides the following relationship between the bulk-drain current I_{db} and the bulk-drain voltage V_{db} after adjusting the applicable model parameters for temperature.

Applicable Range of V_{db} Values	Corresponding I_{gs} Equation
$V_{db} > 80 * V_{tn}$	$I_{db} = IS_{db} * \left(\left(\frac{V_{db}}{V_{tn}} - 79 \right) e^{80} - 1 \right) + V_{db} * G \text{ min}$
$80V_{tn} \geq V_{db}$	$I_{db} = IS_{db} * \left(e^{V_{db}/V_{tn}} - 1 \right) + V_{db} * G \text{ min}$

Where:

- IS_{db} is
 - The product of the **Bulk jct sat current density, JS** parameter value and the **Area of drain, AD** parameter value if both these parameter values and the **Area of source, AS** parameter value are nonzero.
 - The **Bulk saturation current, IS** parameter value, otherwise.

Level 1 Drain Current Model

The block provides the following relationship between the drain current

I_{sd} and the drain-source voltage V_{sd} in normal mode ($V_{sd} \geq 0$) after adjusting the applicable model parameters for temperature.

Normal Mode

Applicable Range of V_{sg} and V_{sd} Values	Corresponding I_{sd} Equation
$V_{sg} - V_{on} \leq 0$	$I_{sd} = 0$

Normal Mode (Continued)

Applicable Range of V_{sg} and V_{sd} Values	Corresponding I_{sd} Equation
$0 < V_{sg} - V_{on} \leq V_{sd}$	$I_{sd} = BETA * (V_{sg} - V_{on})^2 \frac{(1 + LAMBDA * V_{sd})}{2}$
$0 < V_{sd} < V_{sg} - V_{on}$	$I_{sd} = BETA * V_{sd} \left((V_{sg} - V_{on}) - \frac{V_{sd}}{2} \right) (1 + LAMBDA * V_{sd})$

Where:

- V_{on} is:
 - $MTYPE * VBI + GAMMA \sqrt{PHI - V_{sb}}$ if $V_{sb} \leq 0$.
 - $MTYPE * VBI + GAMMA \left(\sqrt{PHI} - \frac{V_{sb}}{2\sqrt{PHI}} \right)$ if $0 < V_{sb} \leq 2 * PHI$.
 - $MTYPE * VBI$ if $V_{sb} > 2 * PHI$.
- $MTYPE$ is -1 .
- $BETA$ is $KP * WIDTH / (LENGTH - 2 * LD)$
- KP is:
 - The **Transconductance, KP** parameter value, if this parameter has a numerical value.
 - $U0 * 3.9 * \epsilon_0 / TOX$, if **Transconductance, KP** is NaN and you specify values for both the **Oxide thickness, TOX** and **Substrate doping, NSUB** parameters.
- $WIDTH$ is the **Width of channel, WIDTH** parameter value.

- *LENGTH* is the **Length of channel**, **LENGTH** parameter value.
- *LD* is the **Lateral diffusion**, **LD** parameter value.
- *VBI* is an built-in voltage value the block uses in calculations. The value is a function of temperature. For a detailed definition, see “Temperature Dependence” on page 2-213.
- *PHI* is:
 - The **Surface potential**, **PHI** parameter value, if this parameter has a numerical value.
 - $2 * kT_{meas} / q * \log(NSUB / n_i)$, if **Surface potential**, **PHI** is NaN and you specify values for both the **Oxide thickness**, **TOX** and **Substrate doping**, **NSUB** parameters.
- *LAMBDA* is the **Channel modulation**, **LAMBDA** parameter value.
- *GAMMA* is:
 - The **Bulk threshold**, **GAMMA** parameter value, if this parameter has a numerical value.
 - $TOX * \sqrt{2 * 11.7 * \epsilon_0 * q * NSUB} / (3.9 * \epsilon_0)$, if **Bulk threshold**, **GAMMA** is NaN and you specify values for both the **Oxide thickness**, **TOX** and **Substrate doping**, **NSUB** parameters.
- ϵ_0 is the permittivity of free space, 8.854214871e-12 F/m.
- n_i is the carrier concentration of intrinsic silicon, 1.45e10 cm⁻³.

The block provides the following relationship between the drain current I_{sd} and the drain-source voltage V_{sd} in inverse mode ($V_{sd} < 0$) after adjusting the applicable model parameters for temperature.

Inverse Mode

Applicable Range of V_{dg} and V_{sd} Values	Corresponding I_{sd} Equation
$V_{dg} - V_{on} \leq 0$	$I_{sd} = 0$
$0 < V_{dg} - V_{on} \leq -V_{sd}$	$I_{sd} = -BETA (V_{dg} - V_{on})^2 (1 - LAMBDA * V_{sd}) / 2$
$0 < V_{sd} < V_{dg} - V_{on}$	$I_{sd} = BETA * V_{sd} \left((V_{dg} - V_{on}) + V_{sd} / 2 \right) (1 - LAMBDA * V_{sd})$

Where:

- V_{on} is:
 - $MTYPE * VBI + GAMMA \sqrt{PHI - V_{db}}$ if $V_{db} \leq 0$
 - $MTYPE * VBI + GAMMA \left(\sqrt{PHI} - \frac{V_{db}}{2\sqrt{PHI}} \right)$ if $0 < V_{db} \leq 2 * PHI$
 - $MTYPE * VBI$ if $V_{db} > 2 * PHI$.

Level 3 Drain Current Model

The block provides the following model for drain current I_{sd} in normal mode ($V_{sd} \geq 0$) after adjusting the applicable model parameters for temperature.

$$I_{SD} = I_{SD0} * Scale_{VMAX} * Scale_{LChan} * Scale_{INV}$$

Where:

- I_{SD0} is the Basic Drain Current Model.
- $Scale_{VMAX}$ is the Velocity Saturation Scaling.
- $Scale_{LChan}$ is the Channel Length Modulation Scaling.
- $Scale_{INV}$ is the Weak Inversion Scaling.

The blocks uses the same model for drain current in inverse mode ($V_{sd} < 0$), with the following substitutions:

- $V_{sb} - V_{sd}$ for V_{sb}
- $V_{sg} - V_{sd}$ for V_{sd}
- $-V_{sd}$ for V_{sd}

Basic Drain Current Model

The block provides the following relationship between the drain current I_{sd} and the drain-source voltage V_{ds} :

$$I_{SD0} = BETA * F_{gate} * \left(V_{SGX} - V_{TH} - \frac{1 + F_B}{2} * V_{SDX} \right) * V_{SDX}$$

- The block calculates BETA as described in “Level 1 Drain Current Model” on page 2-373.
- The block calculates F_{GATE} using the following equation:

$$F_{gate} = \frac{1}{1 + THETA * (V_{sgx} - V_{TH})}$$

- $THETA$ is the **Vgs dependence on mobility**, **THETA** parameter value.

- $V_{sgx} = \max(V_{SG}, V_{on})$
- If you specify a nonzero value for the **Fast surface state density**, **NFS** parameter, the block calculates V_{on} using the following equation:

$$V_{on} = V_{TH} + x_n V_T$$

Otherwise, $V_{on} = V_{TH}$.

- The block calculates x_n using the following equation:

$$x_n = 1 + \frac{q * NFS}{COX} + \frac{\left(GAMMA * F_s * \sqrt{V_{bulk}} + \frac{F_n * V_{bulk}}{WIDTH} \right)}{2 * V_{bulk}}$$

- The block calculates V_{bulk} as follows:
 - If $V_{SB} \leq 0$, $V_{bulk} = PHI - V_{BS}$.
 - Otherwise, the block calculates V_{bulk} using the following equation:

$$V_{bulk} = \frac{PHI}{\left(1 + \frac{V_{SB}}{2 * PHI} \right)^2}$$

- $V_T = kT/q$
- The block calculates V_{TH} using the equation following equation:

$$V_{TH} = V_{BI} - \frac{8.15e^{-22} * ETA}{COX * (LENGTH - 2 * LD)^3} * V_{SD} + GAMMA * F_s * \sqrt{V_{bulk}} + F_n * V_{bulk}$$

- For information about how the block calculates V_{BI} , see “Temperature Dependence” on page 2-387.

- *ETA* is the **Vds dependence threshold volt, ETA** parameter value.
- $COX = \epsilon_{ox} / TOX$, where ϵ_{ox} is the permittivity of the oxide and *TOX* is the **Oxide thickness, TOX** parameter value.
- If you specify a nonzero value for the **Junction depth, XJ** parameter and a value for the **Substrate doping, NSUB** parameter, the block calculates F_s using the following equations:

$$\alpha = \frac{2\epsilon_{si}}{qNSUB}$$

$$XD = \sqrt{\alpha}$$

$$wc = .0631353 + .8013292 * \frac{XD * \sqrt{V_{bulk}}}{XJ}$$

$$-.01110777 * \left(\frac{XD * \sqrt{V_{bulk}}}{XJ} \right)^2 + \frac{LD}{XJ}$$

$$F_s = 1 - \left(wc * \sqrt{1 - \left(\frac{XD * \sqrt{V_{bulk}}}{XJ + XD * \sqrt{V_{bulk}}} \right)^2} - \frac{LD}{XJ} \right)$$

where ϵ_{si} is the permittivity of silicon.

Otherwise, $F_s = 1$.

- The block calculates F_B using the following equation:

$$F_B = \frac{GAMMA * F_s}{4 * \sqrt{V_{bulk}}} + F_n$$

- The block calculates F_n using the following equation:

$$F_n = \frac{DELTA * \pi * \epsilon_{si}}{2 * COX * WIDTH}$$

- **DELTA** is the **Width effect on threshold**, **DELTA** parameter value.
- V_{SDX} is the lesser of V_{SD} and the saturation voltage, V_{dsat} .
 - If you specify a positive value for the **Max carrier drift velocity**, **VMAX** parameter, the block calculates V_{dsat} using the following equation:

$$V_{dsat} = \frac{V_{sgx} - V_{TH}}{1 + F_B} + \frac{(LENGTH - 2 * LD) * VMAX}{UO * F_{gate}}$$

$$- \sqrt{\left(\frac{V_{sgx} - V_{TH}}{1 + F_B} \right)^2 + \left(\frac{(LENGTH - 2 * LD) * VMAX}{UO * F_{gate}} \right)^2}$$

Otherwise, the block calculates V_{dsat} using the following equation:

$$V_{dsat} = \frac{V_{sgx} - V_{TH}}{1 + F_B}$$

Velocity Saturation Scaling

If you specify a positive value for the **Max carrier drift velocity**, **VMAX** parameter, the block calculates $Scale_{VMAX}$ using the following equation:

$$Scale_{VMAX} = \frac{1}{1 + \frac{UO * F_{gate}}{(LENGTH - 2 * LD) * VMAX} * V_{SDX}}$$

Otherwise, $Scale_{VMAX} = 1$.

Channel Length Modulation Scaling

The block scales the drain current to account for channel length modulation if the block meets all of the following criteria:

- $V_{SD} > V_{sat}$
- The **Max carrier drift velocity**, **VMAX** parameter value is zero or α is nonzero.

The block scales the drain current using the following equation:

$$Scale_{LChan} = \frac{1}{1 - \frac{\Delta l}{(LENGTH - 2 * LD)}}$$

The block uses the following procedure to calculate Δl :

- 1 The block first calculates the intermediate value Δl_0 .
 - If you specify a positive value for the **Max carrier drift velocity**, **VMAX** parameter, the block computes the intermediate value g_{dsat} as the greater of $1e-12$ and the result of the following equation:

$$I_{SD0} * \left(1 - \frac{1}{1 + Scale_{g_{dsat}} * V_{SDX}} \right) * Scale_{g_{dsat}}$$

where:

$$Scale_{g_{dsat}} = \frac{UO * F_{gate}}{(LENGTH - 2 * LD) * VMAX}$$

Then, the block uses the following equation to calculate the intermediate value Δl_0 :

$$\Delta l_0 = \sqrt{\left(\frac{KA * I_{SD}}{2 * (LENGTH - 2 * LD) * g_{dsat}} \right)^2 + KA * (V_{SD} - V_{dsat})} - \frac{KA * I_{SD}}{2 * (LENGTH - 2 * LD) * g_{dsat}}$$

where KA is the product of the **Mobility modulation, KAPPA** parameter value and a .

- Otherwise, the block uses the following equation to calculate the intermediate value Δl_0 :

$$\Delta l = \sqrt{KA * (V_{SD} - V_{dsat})}$$

2 The block checks for punch through and calculates Δl .

- If Δl_0 is greater than $(LENGTH - 2 * LD) / 2$, the block calculates Δl using the following equation:

$$\Delta l = \left(1 - \frac{(LENGTH - 2 * LD)}{4 * \Delta l_0} \right) * (LENGTH - 2 * LD)$$

- Otherwise, $\Delta l = \Delta l_0$.

Weak Inversion Scaling

If V_{SG} is less than V_{on} , the block calculates $Scale_{INV}$ using the following equation:

$$Scale_{INV} = e^{\frac{V_{sg} - V_{on}}{x_n * V_T}}$$

Otherwise, $Scale_{INV} = 1$.

Junction Charge Model

The block models the following junction charges:

- Junction Overlap Charges
- Bulk Junction Charges

Junction Overlap Charges

The block calculates the following junction overlap charges:

- $Q_{SG} = CGSO * WIDTH * V_{sg}$

Where:

- Q_{SG} is the gate-source overlap charge.
- $CGSO$ is the **G-S overlap capacitance**, **CGSO** parameter value.
- $WIDTH$ is the **Width of channel**, **WIDTH** parameter value.

- $Q_{DG} = CGDO * WIDTH * V_{dg}$

Where:

- Q_{DG} is the gate-drain overlap charge.
- $CGDO$ is the **G-D overlap capacitance**, **CGDO** parameter value.

- $Q_{BG} = CGBO * (LENGTH - 2 * LD) * V_{bg}$

Where:

- Q_{BG} is the gate-bulk overlap charge.
- $CGBO$ is the **G-B overlap capacitance**, **CGBO** parameter value.
- $LENGTH$ is the **Length of channel**, **LENGTH** parameter value.
- LD is the **Lateral diffusion**, **LD** parameter value.

Bulk Junction Charges

The block provides the following relationship between the bulk-drain bottom junction charge Q_{bottom} and the junction voltage V_{db} after adjusting the applicable model parameters for temperature.

Applicable Range of V_{db} Values	Corresponding Q_{bottom} Equation
$V_{db} < FC * PB$	$Q_{bottom} = \frac{CBD * PB * \left(1 - \left(1 - \frac{V_{db}}{PB} \right)^{1-MJ} \right)}{1 - MJ} \quad \text{if } CBD > 0.$ $Q_{bottom} = \frac{CJ * AD * PB * \left(1 - \left(1 - \frac{V_{db}}{PB} \right)^{1-MJ} \right)}{1 - MJ} \quad \text{otherwise.}$
$V_{db} \geq FC * PB$	$Q_{bottom} = CBD *$ $\left(F1 + \frac{F3 * (V_{db} - FC * PB) + \frac{MJ * (V_{db}^2 - (FC * PB)^2)}{2 * PB}}{F2} \right)$ <p>if $CBD > 0$.</p> $Q_{bottom} = CJ * AD *$ $\left(F1 + \frac{F3 * (V_{db} - FC * PB) + \frac{MJ * (V_{db}^2 - (FC * PB)^2)}{2 * PB}}{F2} \right)$ <p>otherwise.</p>

Where:

- *PB* is the **Bulk junction potential, PB** parameter value.
- *FC* is the **Capacitance coefficient FC** parameter value.
- *CBD* is the **Zero-bias BD capacitance, CBD** parameter value.
- *CJ* is the **Bottom junction cap per area, CJ** parameter value.
- *AD* is the **Area of drain, AD** parameter value.
- *MJ* is the **Bottom grading coefficient, MJ** parameter value.

- $$F1 = \frac{PB * (1 - (1 - FC)^{1 - MJ})}{1 - MJ}$$
- $$F2 = (1 - FC)^{1 + MJ}$$
- $$F3 = 1 - FC * (1 + MJ)$$

The block uses the equations in the preceding table to calculate the bulk-source bottom junction charge, with the following substitutions:

- V_{sb} replaces V_{db} .
- *AS* (the **Area of source, AS** parameter value) replaces *AD*.
- *CBS* (the **Zero-bias BS capacitance, CBS** parameter value) replaces *CBD*.

The block provides the following relationship between the bulk-drain sidewall junction charge $Q_{sidewall}$ and the junction voltage V_{db} after adjusting the applicable model parameters for temperature.

Applicable Range of V_{db} Values	Corresponding $Q_{sidewall}$ Equation
$V_{db} < FC * PB$	$Q_{sidewall} = \frac{CJSW * PD * PB * \left(1 - \left(1 - \frac{V_{db}}{PB} \right)^{1-MJSW} \right)}{1 - MJSW}$
$V_{db} \geq FC * PB$	$Q_{sidewall} = CJSW * PD * \left(F1 + \frac{F3 * (V_{db} - FC * PB) + \frac{MJSW * (V_{db}^2 - (FC * PB)^2)}{2 * PB}}{F2} \right)$

Where:

- $CJSW$ is the **Side jct cap/area of jct perimeter**, $CJSW$ parameter value.
- PD is the **Perimeter of drain**, AD parameter value.
- $MJSW$ is the **Side grading coefficient**, $MJSW$ parameter value.

- $F1 = \frac{PB * (1 - (1 - FC)^{1-MJSW})}{1 - MJSW}$

- $F2 = (1 - FC)^{1+MJSW}$

- $F3 = 1 - FC * (1 + MJSW)$

The block uses the equations in the preceding table to calculate the bulk-source sidewall junction charge and the sidewall junction voltage, with the following substitutions:

- V_{sb} replaces V_{db} .
- PS (the **Perimeter of source, PS** parameter value) replaces PD .

Temperature Dependence

Several transistor parameters depend on temperature. There are two ways to specify the transistor temperature:

- When you select `Device` temperature for the **Model temperature dependence using** parameter, the transistor temperature is

$$T = T_C + T_O$$

where:

- T_C is the **Circuit temperature** parameter value from the SPICE Environment Parameters block. If this block doesn't exist in the circuit, T_C is the default value of this parameter.
- T_O is the **Offset local circuit temperature, TOFFSET** parameter value.
- When you select `Fixed` temperature for the **Model temperature dependence using** parameter, the transistor temperature is the **Fixed circuit temperature, TFIXED** parameter value.

The block provides the following relationship between the transconductance KP and the transistor temperature T :

$$KP(T) = \frac{KP}{\left(\frac{T}{T_{meas}}\right)^{3/2}}$$

where:

- KP is the **Transconductance, KP** parameter value.
- T_{meas} is the **Parameter extraction temperature, TMEAS** parameter value.

The block provides the following relationship between the surface potential PHI and the transistor temperature T :

$$PHI(T) = \frac{T}{T_{meas}} \left(PHI + \frac{kT_{meas}}{q} \left(\log \left(\frac{T_{meas}}{300.15} \right)^3 + \frac{q}{k} \left(\frac{1.115}{300.15} - \frac{EG_{T_{meas}}}{T_{meas}} \right) \right) \right) - \frac{kT}{q} \left(\log \left(\frac{T}{300.15} \right)^3 + \frac{q}{k} \left(\frac{1.115}{300.15} - \frac{EG_T}{T} \right) \right)$$

where:

- $EG_{T_{meas}} = 1.16eV - (7.02e - 4 * T_{meas}^2) / (T_{meas} + 1108)$
- $EG_T = 1.16eV - (7.02e - 4 * T^2) / (T + 1108)$

The block provides the following relationship between the built-in voltage VBI and the transistor temperature T :

$$VBI(T) = VTO + MTYPE * \left(\frac{PHI(T) - PHI}{2} - GAMMA \sqrt{PHI} \right) + \frac{EG_{T_{meas}} - EG_T}{2}$$

where:

- VTO is:
 - The **Threshold voltage, VTO** parameter value, if this parameter has a numerical value.

- $\Phi - 3.25 + EG_{T_{meas}} / 2 + MTYPE * PHI / 2 - NSS * q * TOX / (3.9 * \epsilon_0)$
 $+ MTYPE * (GAMMA * \sqrt{PHI} + PHI)$, if **Threshold voltage**, **VTO** is NaN and you specify values for both the **Oxide thickness**, **TOX** and **Substrate doping**, **NSUB** parameters.
- Φ is:
 - 3.2, if **TPG** (the **Gate type?**, **TPG** parameter value) is 0.
 - $3.25 + EG_{T_{meas}} / 2 - MTYPE * TPG * EG_{T_{meas}} / 2$, otherwise.
- **GAMMA** is:
 - The **Bulk threshold**, **GAMMA** parameter value, if this parameter has a numerical value.
 - $TOX * \sqrt{2 * 11.7 * \epsilon_0 * q * NSUB} / (3.9 * \epsilon_0)$, if **Bulk threshold**, **GAMMA** is NaN and you specify values for both the **Oxide thickness**, **TOX** and **Substrate doping**, **NSUB** parameters.

The block provides the following relationship between the bulk saturation current IS and the transistor temperature T :

$$IS(T) = IS * e^{\frac{-qEG_T}{ND*kT} + \frac{qEG_{T_{meas}}}{ND*kT_{meas}}}$$

where:

- ND is the **Emission coefficient**, **ND** parameter value.
- IS is the **Bulk saturation current**, **IS** parameter value.

The block provides the following relationship between the bulk junction saturation current density JS and the transistor temperature T :

$$JS(T) = JS * e^{\frac{-qEG_T}{ND*kT} + \frac{qEG_{T_{meas}}}{ND*kT_{meas}}}$$

where:

- JS is the **Bulk jct sat current density**, **JS** parameter value.

The block provides the following relationship between the bulk junction potential PB and the transistor temperature T :

$$PB(T) = \frac{PB + \frac{kT_{meas}}{q} \left(\log \left(\frac{T_{meas}}{300.15} \right)^3 + \frac{q}{k} \left(\frac{1.115}{300.15} - \frac{EG_{T_{meas}}}{T} \right) \right)}{T_{meas}/T} - \frac{kT}{q} \left(\log \left(\frac{T}{300.15} \right)^3 + \frac{q}{k} \left(\frac{1.115}{300.15} - \frac{EG_T}{T} \right) \right)$$

where:

- PB is the **Bulk junction potential**, **PB** parameter value.

The block provides the following relationship between the bulk-drain junction capacitance CBD and the transistor temperature T :

$$CBD(T) = CBD \frac{pbo + MJ * (4 * 10^4 * (T - 300.15) * pbo - (PB(T) - pbo))}{pbo + MJ * (4 * 10^4 * (T_{meas} - 300.15) * pbo - (PB - pbo))}$$

where:

- CBD is the **Zero-bias BD capacitance**, **CBD** parameter value.
- MJ is the **Bottom grading coefficient**, **MJ** parameter value.

- $pbo = \frac{PB + \frac{kT_{meas}}{q} \left(\log \left(\frac{T_{meas}}{300.15} \right)^3 + \frac{q}{k} \left(\frac{1.115}{300.15} - \frac{EG_{T_{meas}}}{T} \right) \right)}{T_{meas}/300.15}$

The block uses the $CBD(T)$ equation to calculate:

- The bulk-source junction capacitance by substituting CBS (the **Zero-bias BS capacitance, CBS** parameter value) for CBD .
- The bottom junction capacitance by substituting CJ (the **Bottom junction cap per area, CJ** parameter value) for CBD .

The block provides the following relationship between the sidewall junction capacitance $CJSW$ and the transistor temperature T :

$$CJSW(T) = CJSW \frac{pbo + MJSW * (4 * 10^4 * (T - 300.15) * pbo - (PB(T) - pbo))}{pbo + MJSW * (4 * 10^4 * (T_{meas} - 300.15) * pbo - (PB - pbo))}$$

where:

- $MJSW$ is the **Side grading coefficient, MJSW** parameter value.

Basic Assumptions and Limitations

The model is based on the following assumptions:

- The PMOS block does not support noise analysis.
- The PMOS block applies initial conditions across junction capacitors and not across the block ports.

Dialog Box and Parameters

Model Selection Tab

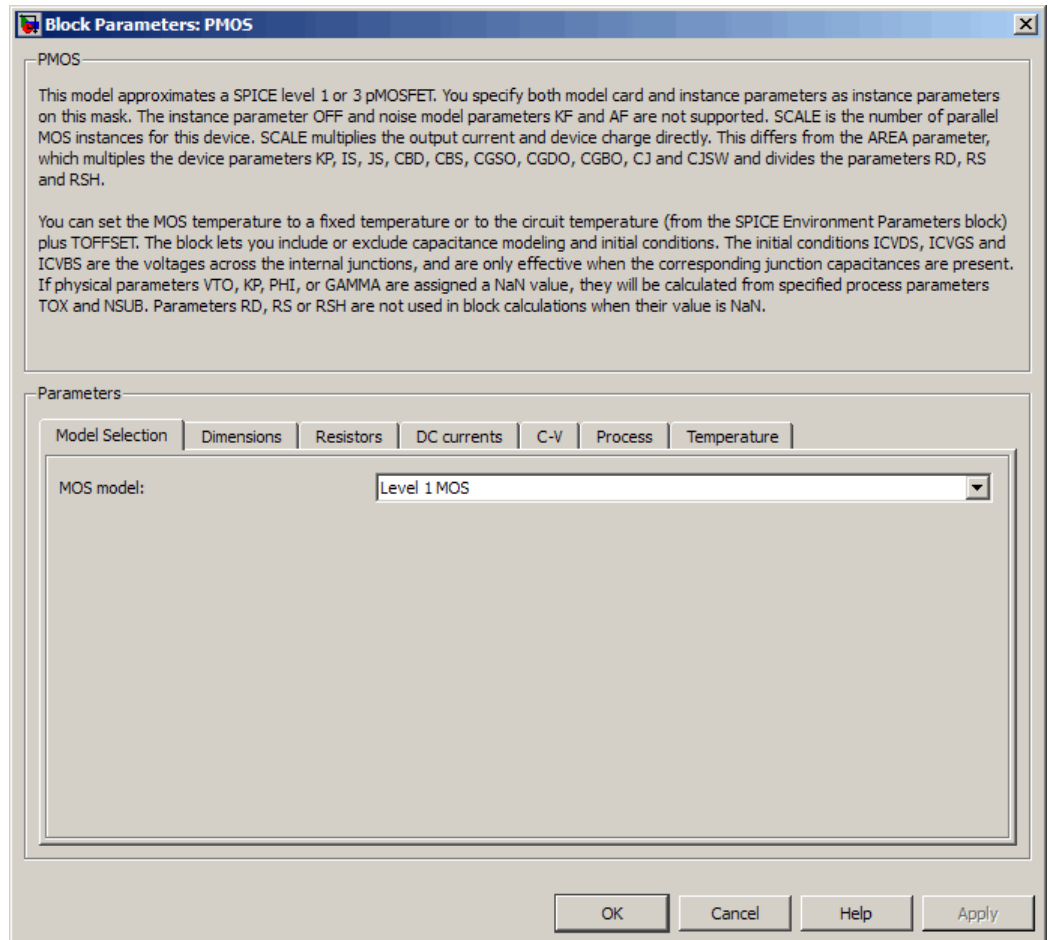

MOS model

Select one of the following MOSFET model options:

- Level 1 MOS — Use the “Level 1 Drain Current Model” on page 2-373. This is the default option.

- Level 3 MOS — Use the “Level 3 Drain Current Model” on page 2-376.

Dimensions Tab

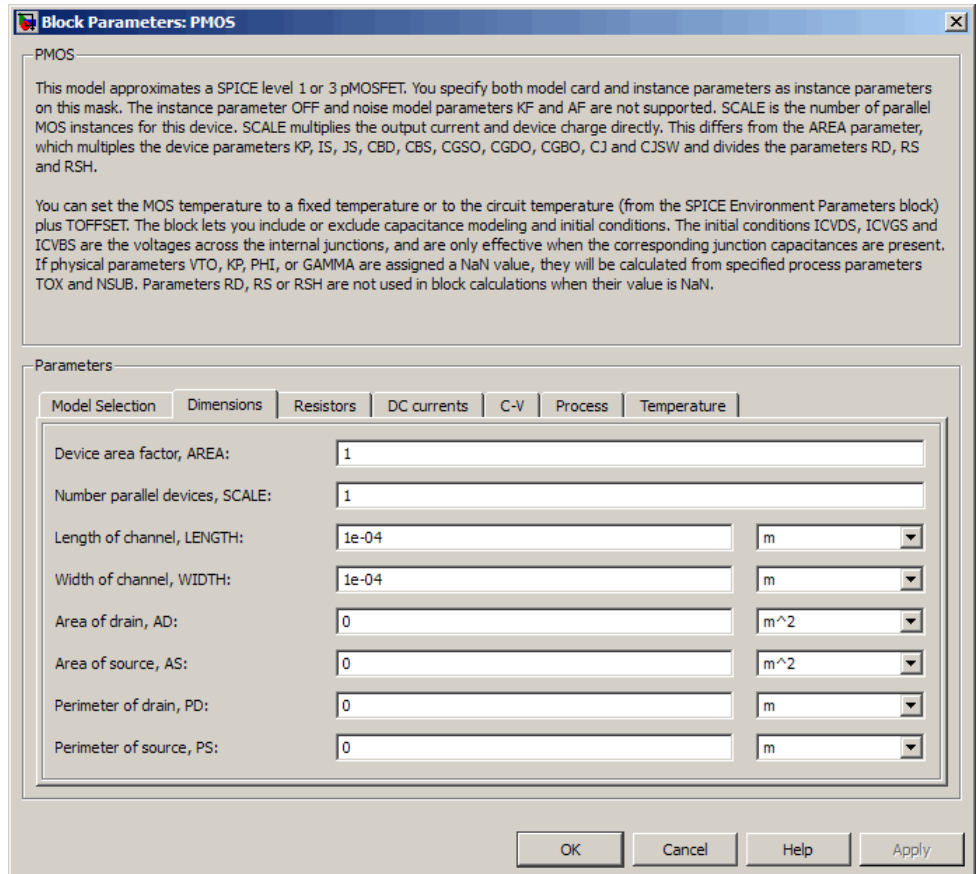

Device area factor, AREA

The transistor area. This value multiplies the following parameter values:

- **Transconductance, KP**
- **Bulk saturation current, IS**
- **Bulk jct sat current density, JS**
- **Zero-bias BD capacitance, CBD**
- **Zero-bias BS capacitance, CBS**
- **G-S overlap capacitance, CGSO**
- **G-D overlap capacitance, CGDO**
- **G-B overlap capacitance, CGBO**
- **Bottom junction cap per area CJ**
- **Side jct cap/area of jct perimeter CJSW**

It divides the following parameter values:

- **Drain resistance, RD**
- **Source resistance, RS**
- **Sheet resistance, RSH**

The default value is 1. The value must be greater than 0.

Number of parallel devices, SCALE

The number of parallel MOS instances for this device. This parameter multiplies the output current and device charge. The default value is 1. The value must be greater than 0.

Length of channel, LENGTH

Length of the channel between the source and drain. The default value is 1e-04 m.

Width of channel, WIDTH

Width of the channel between the source and drain. The default value is 1e-04 m.

Area of drain, AD

Area of the transistor drain diffusion. The default value is 0 m².
The value must be greater than or equal to 0.

Area of source, AS

Area of the transistor source diffusion. The default value is 0 m².
The value must be greater than or equal to 0.

Perimeter of drain, PD

Perimeter of the transistor drain diffusion. The default value
is 0 m.

Perimeter of source, PS

Perimeter of the transistor source diffusion. The default value
is 0 m.

Resistors Tab

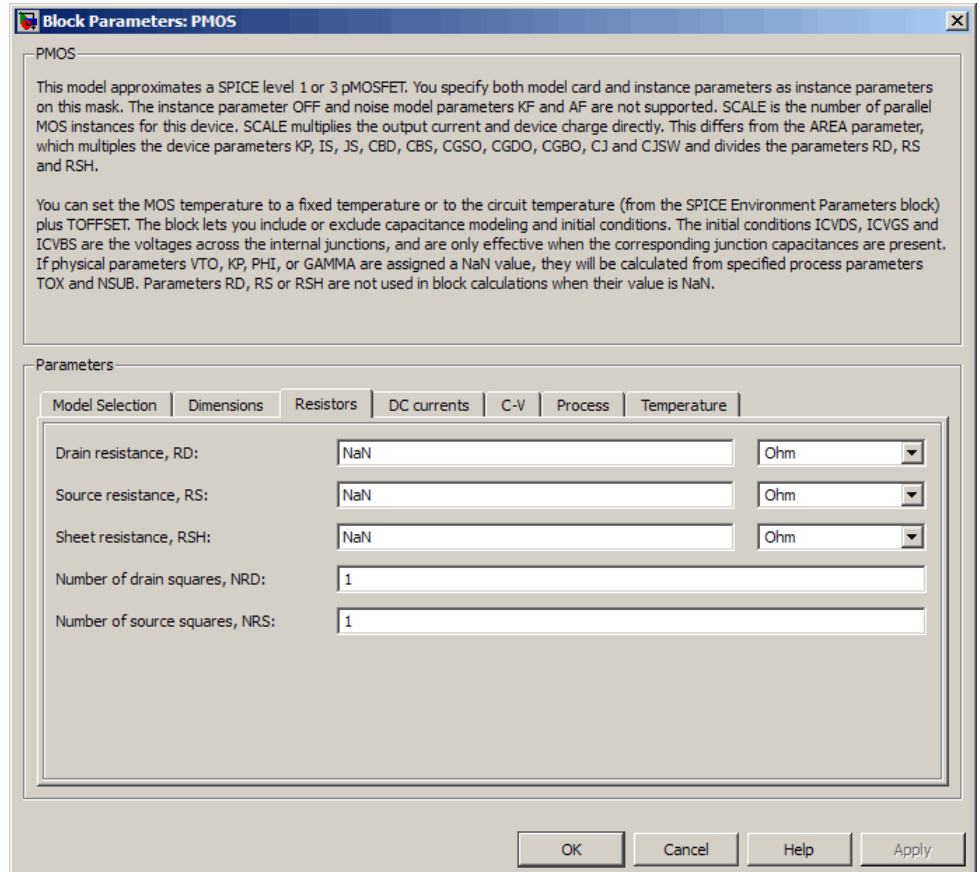

Drain resistance, RD

The transistor drain ohmic resistance. The default value is Nan Ω . This value means the parameter is unspecified, so the block calculates the drain resistance as described in “Resistance Calculations” on page 2-370. The value must be equal to 0 or

greater than or equal to R_{min} . R_{min} is a built-in model constant whose value is $1e-12$.

Source resistance, RS

The transistor source ohmic resistance. The default value is $Nan \Omega$. This value means the parameter is unspecified, so the block calculates the drain resistance as described in “Resistance Calculations” on page 2-370. The value must be equal to 0 or greater than or equal to R_{min} . R_{min} is a built-in model constant whose value is $1e-12$.

Sheet resistance, RSH

Resistance per square of the transistor source and drain. The default value is $Nan \Omega$. This value means the parameter is unspecified. The block only uses this parameter value if you do not specify one or both of the **Drain resistance, RD** and **Source resistance, RS** parameter values, as described in “Resistance Calculations” on page 2-370. The value must be greater than or equal to 0.

Number of drain squares, NRD

Number of squares of resistance that make up the transistor drain diffusion. The default value is 1. The value must be greater than or equal to 0. The block only uses this parameter value if you do not specify one or both of the **Drain resistance, RD** and **Source resistance, RS** parameter values, as described in “Resistance Calculations” on page 2-370.

Number of source squares, NRS

Number of squares of resistance that make up the transistor source diffusion. The default value is 1. The value must be greater than or equal to 0. The block only uses this parameter value if you do not specify one or both of the **Drain resistance, RD** and **Source resistance, RS** parameter values, as described in “Resistance Calculations” on page 2-370.

DC Currents Tab

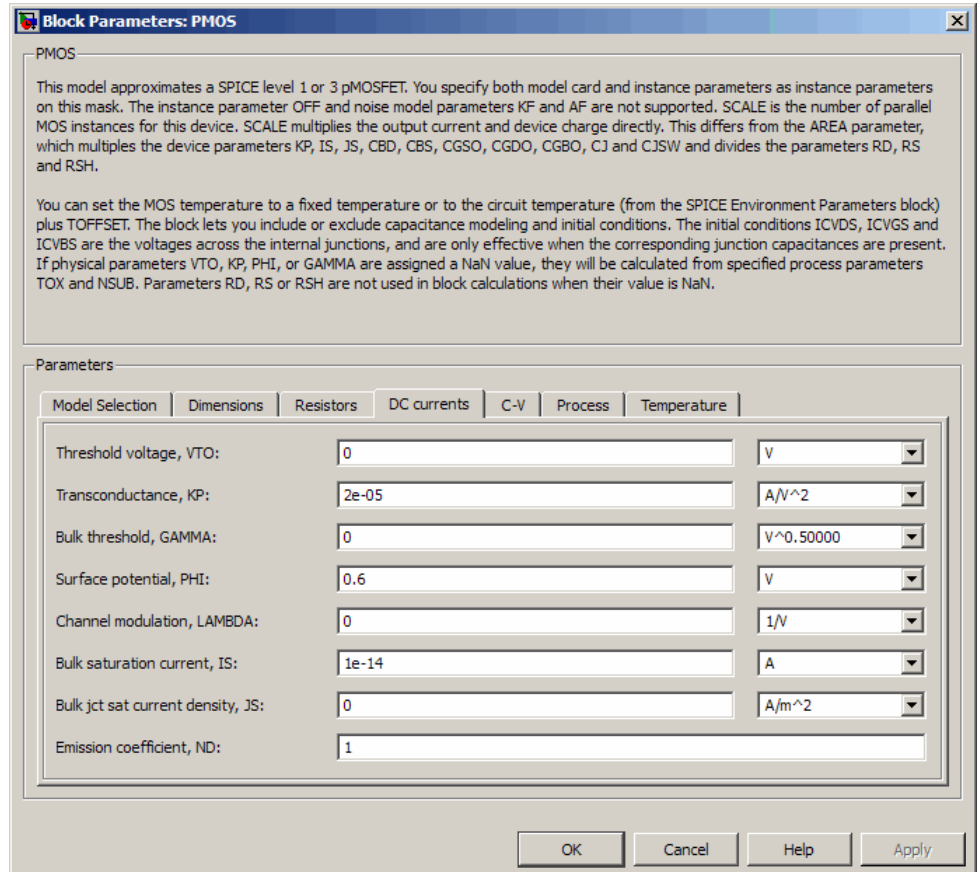

Threshold voltage, VTO

The gate-source voltage above which the transistor produces a nonzero drain current. The default value is 0 V. If you assign this parameter a value of NaN, the block calculates the value from the specified values of the **Oxide thickness, TOX** and **Substrate**

doping, NSUB parameters. For more information about this calculation, see “Temperature Dependence” on page 2-213.

Transconductance, KP

The derivative of drain current with respect to gate voltage. The default value is $2e-05$ A/V². The value must be greater than or equal to 0. If you assign this parameter a value of NaN, the block calculates the value from the specified values of the **Oxide thickness, TOX** and **Substrate doping, NSUB** parameters. For more information about this calculation, see “Level 1 Drain Current Model” on page 2-199 or “Level 3 Drain Current Model” on page 2-376 as appropriate for the selected value of the **MOS model** parameter.

Bulk threshold, GAMMA

Body effect parameter, which relates the threshold voltage, VTH, to the body bias, VBS, as described in “Level 1 Drain Current Model” on page 2-199. The default value is $0 \sqrt{V}$. The value must be greater than or equal to 0. If you assign this parameter a value of NaN, the block calculates the value from the specified values of the **Oxide thickness, TOX** and **Substrate doping, NSUB** parameters. For more information about this calculation, see “Level 1 Drain Current Model” on page 2-199 or “Level 3 Drain Current Model” on page 2-376 as appropriate for the selected value of the **MOS model** parameter.

Surface potential, PHI

Twice the voltage at which the surface electron concentration becomes equal to the intrinsic concentration and the device transitions between depletion and inversion conditions. The default value is 0.6 V. The value must be greater than or equal to 0. If you assign this parameter a value of NaN, the block calculates the value from the specified values of the **Oxide thickness, TOX** and **Substrate doping, NSUB** parameters. For more information about this calculation, see “Level 1 Drain Current Model” on page 2-199 or “Level 3 Drain Current Model” on page 2-376 as appropriate for the selected value of the **MOS model** parameter.

Channel modulation, LAMBDA

The channel-length modulation. This parameter is only visible when you select Level 1 MOS for the **MOS model** parameter. The default value is 0 1/V.

Bulk saturation current, IS

The magnitude of the current that the junction approaches asymptotically for very large reverse bias levels. The default value is 1e-14 A. The value must be greater than or equal to 0.

Bulk jct sat current density, JS

The magnitude of the current per unit area that the junction approaches asymptotically for very large reverse bias levels. The default value is 0 A/m². The value must be greater than or equal to 0.

Emission coefficient, ND

The transistor emission coefficient or ideality factor. The default value is 1. The value must be greater than 0.

Width effect on threshold, DELTA

The factor that controls the effect of transistor width on threshold voltage. This parameter is only visible when you select Level 3 MOS for the **MOS model** parameter. The default value is 0.

Max carrier drift velocity, VMAX

The maximum drift velocity of the carriers. This parameter is only visible when you select Level 3 MOS for the **MOS model** parameter. The default value is 0 m/s.

Fast surface state density, NFS

The fast surface state density adjusts the drain current for the mobility reduction caused by the gate voltage. This parameter is only visible when you select Level 3 MOS for the **MOS model** parameter. The default value is 0 1/cm².

Vds dependence threshold volt, ETA

The coefficient that controls how the threshold voltage depends on the drain-source voltage in the drain current calculation. This

parameter is only visible when you select Level 3 MOS for the **MOS model** parameter. The default value is 0.

Vgs dependence on mobility, THETA

The coefficient that controls how the mobility affects the gate voltage in the drain current calculation. This parameter is only visible when you select Level 3 MOS for the **MOS model** parameter. The default value is 0 1/V.

Mobility modulation, KAPPA

The coefficient that controls how the mobility affects the channel length in the drain current calculation. This parameter is only visible when you select Level 3 MOS for the **MOS model** parameter. The default value is 0.2.

C-V Tab

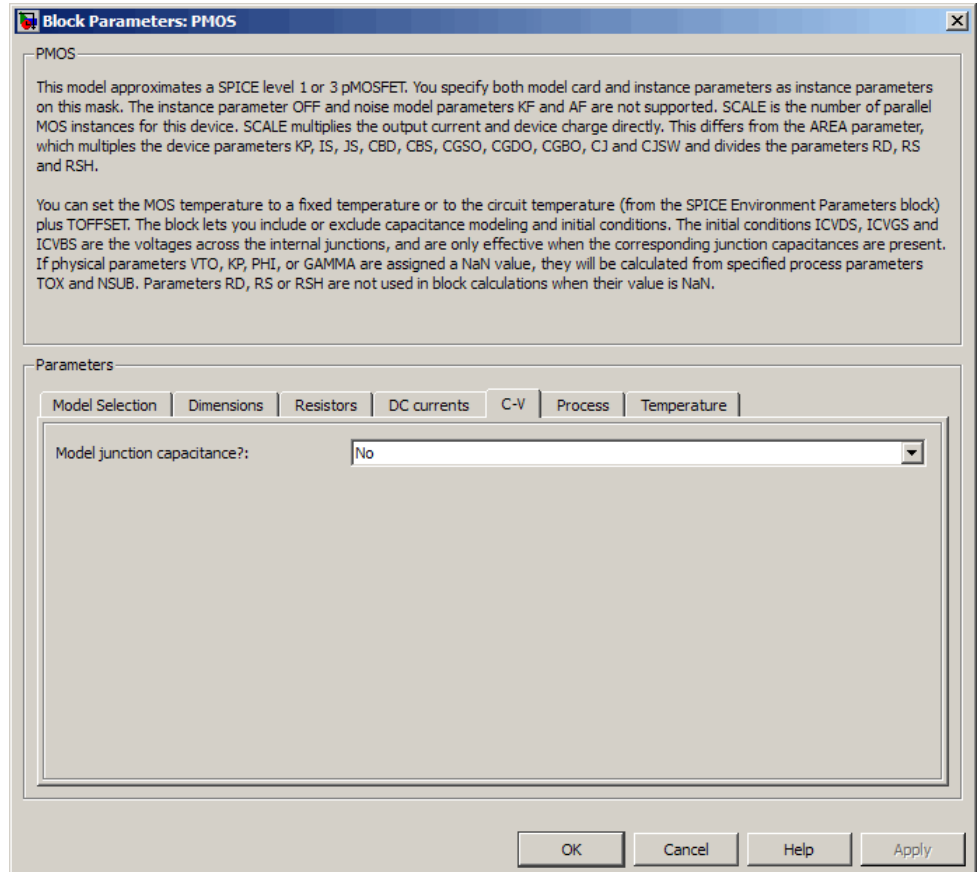

Model junction capacitance

Select one of the following options for modeling the junction capacitance:

- No — Do not include junction capacitance in the model. This is the default option.

- **Yes** — Specify zero-bias junction capacitance, junction potential, grading coefficient, forward-bias depletion and capacitance coefficient.

G-S overlap capacitance, CGSO

Gate-source capacitance due to the diffusion that occurs when the device operates in depletion mode. This parameter is only visible when you select **Yes** for the **Model junction capacitance** parameter. The default value is 0 F/m. The value must be equal to 0 or greater than or equal to Cmin. Cmin is a built-in model constant whose value is 1e-18.

G-D overlap capacitance, CGDO

Gate-drain capacitance due to the diffusion that occurs when the device operates in depletion mode. This parameter is only visible when you select **Yes** for the **Model junction capacitance** parameter. The default value is 0 F/m. The value must be equal to 0 or greater than or equal to Cmin. Cmin is a built-in model constant whose value is 1e-18.

G-B overlap capacitance, CGBO

Gate-base capacitance due to the diffusion that occurs when the device operates in depletion mode. This parameter is only visible when you select **Yes** for the **Model junction capacitance** parameter. The default value is 0 F/m. The value must be equal to 0 or greater than or equal to Cmin. Cmin is a built-in model constant whose value is 1e-18.

Zero-bias BD capacitance, CBD

The value of the capacitance placed between the base and the drain. This parameter is only visible when you select **Yes** for the **Model junction capacitance** parameter. The default value is 0 F. The value must be equal to 0 or greater than or equal to Cmin. Cmin is a built-in model constant whose value is 1e-18.

Zero-bias BS capacitance, CBS

The value of the capacitance placed between the base and the source. This parameter is only visible when you select **Yes** for the **Model junction capacitance** parameter. The default value is 0

F. The value must be equal to 0 or greater than or equal to C_{min} . C_{min} is a built-in model constant whose value is $1e-18$.

Bottom junction cap per area CJ

Zero-bias bulk junction bottom capacitance per junction area. This parameter is only visible when you select **Yes** for the **Model junction capacitance** parameter. The default value is 0 F/m^2 . The value must be equal to 0 or greater than or equal to C_{min} . C_{min} is a built-in model constant whose value is $1e-18$.

Bottom grading coefficient, MJ

The transistor bottom grading coefficient. This parameter is only visible when you select **Yes** for the **Model junction capacitance** parameter. The default value is 0.5. The value must be equal to 0 or less than M_{Gmax} . M_{Gmax} is a built-in model constant whose value is 0.9.

Side jct cap/area of jct perimeter CJSW

Zero-bias bulk junction sidewall capacitance per junction perimeter. This parameter is only visible when you select **Yes** for the **Model junction capacitance** parameter. The default value is 0 F/m . The value must be equal to 0 or greater than or equal to C_{min} . C_{min} is a built-in model constant whose value is $1e-18$.

Side grading coefficient, MJSW

The transistor sidewall grading coefficient. This parameter is only visible when you select **Yes** for the **Model junction capacitance** parameter. The default value is 0.5. The value must be equal to 0 or less than M_{Gmax} . M_{Gmax} is a built-in model constant whose value is 0.9.

Bulk junction potential, PB

The potential across the bulk junction. This parameter is only visible when you select **Yes** for the **Model junction capacitance** parameter. The default value is 0.8 V. The value must be equal to 0 or greater than or equal to V_{Jmin} . V_{Jmin} is a built-in model constant whose value is 0.01.

Capacitance coefficient FC

The fitting coefficient that quantifies the decrease of the depletion capacitance with applied voltage. This parameter is only visible when you select **Yes** for the **Model junction capacitance** parameter. The default value is 0.5. The value must be equal to 0 or less than or equal to FCmax. FCmax is a built-in model constant whose value is 0.95.

Specify initial condition

Select one of the following options for specifying an initial condition:

- **No** — Do not specify an initial condition for the model. This is the default option.
- **Yes** — Specify the initial diode voltage.

Note The PMOS block applies the initial diode voltage across the junction capacitors and not across the ports.

Initial condition voltage ICVDS

Drain-source voltage at the start of the simulation. This parameter is only visible when you select **Yes** for the **Model junction capacitance** and **Yes** for the **Specify initial condition** parameter. The default value is 0 V.

Initial condition voltage ICVGS

Gate-source voltage at the start of the simulation. This parameter is only visible when you select **Yes** for the **Model junction capacitance** and **Yes** for the **Specify initial condition** parameter. The default value is 0 V.

Initial condition voltage ICVBS

Bulk-source voltage at the start of the simulation. This parameter is only visible when you select **Yes** for the **Model junction capacitance** and **Yes** for the **Specify initial condition** parameter. The default value is 0 V.

Process Tab

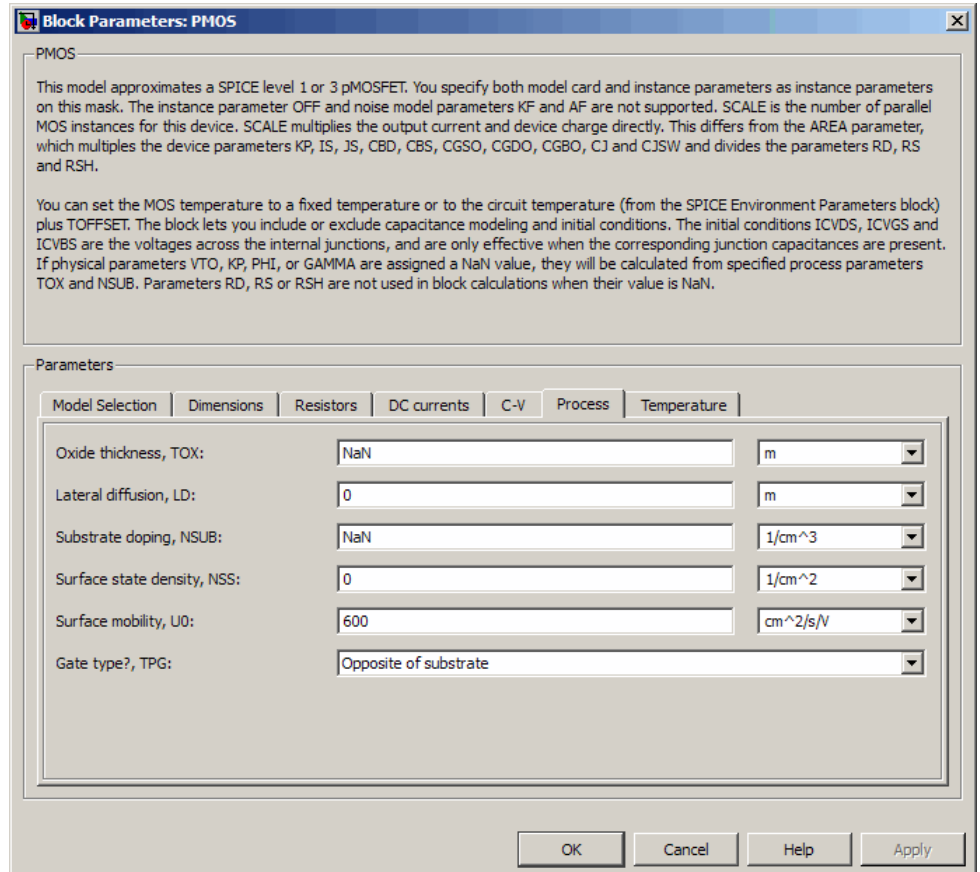

Oxide thickness, TOX

Thickness of the gate oxide. The default value is NaN m. The value must be greater than or equal to 0.

Note When you select Level 3 MOS for the **MOS model** parameter, the block uses a value of $1e-7$ rather than NaN by default.

Lateral diffusion, LD

Length of lateral diffusion. The default value is 0 m.

Substrate doping, NSUB

Substrate doping. The default value is NaN $1/\text{cm}^3$. The value must be greater than or equal to $1.45e10$ (the carrier concentration of intrinsic silicon).

Surface state density, NSS

Substrate doping. The default value is 0 $1/\text{cm}^2$.

Surface mobility, U0

Zero-bias surface mobility coefficient. The default value is 600 $\text{cm}^2/\text{V}/\text{s}$.

Junction depth, XJ

Junction depth. This parameter is only visible when you select Level 3 MOS for the **MOS model** parameter. The default value is 0 m.

Gate type?,TPG

Select one of the following MOSFET gate materials (as compared to the substrate):

- **Opposite of substrate** — The gate material is the opposite of the substrate. This means that $\text{TPG} = 1$ in the device equations. This is the default option.
- **Same as substrate** — The gate material is the same as the substrate. This means that $\text{TPG} = -1$ in the device equations.
- **Aluminum** — The gate material is aluminum. This means that $\text{TPG} = 0$ in the device equations.

Temperature Tab

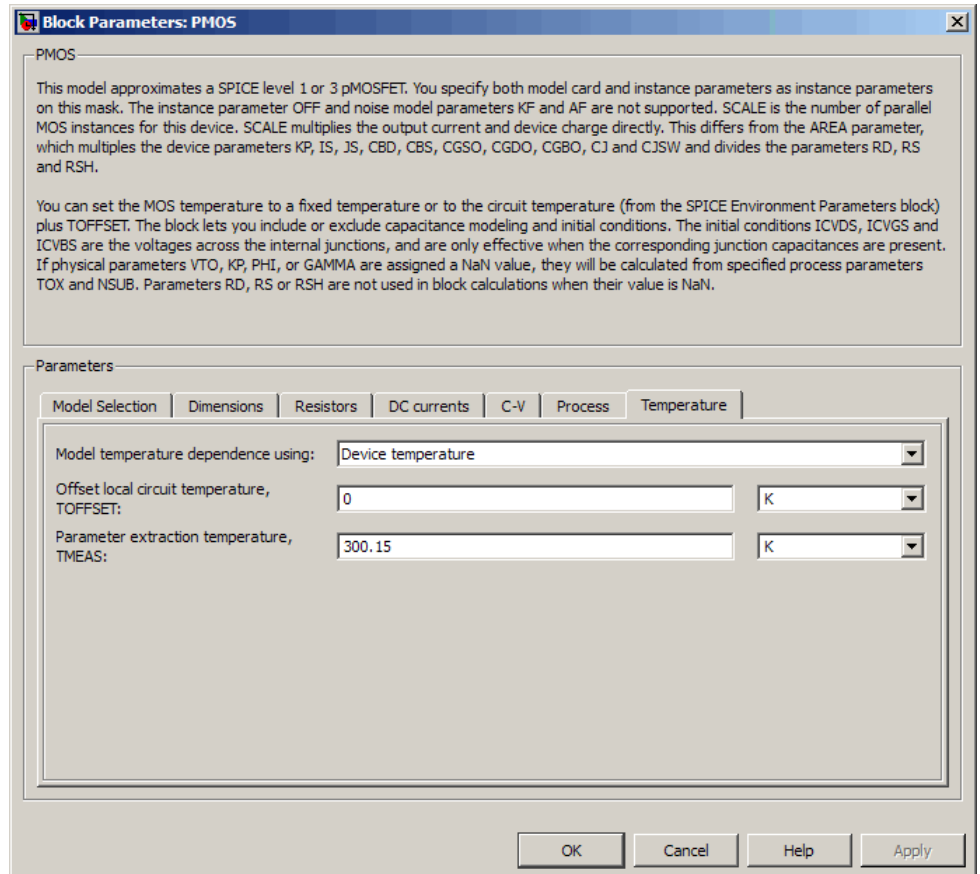

Model temperature dependence using

Select one of the following options for modeling the diode temperature dependence:

- **Device temperature** — Use the device temperature, which is the **Circuit temperature** value plus the **Offset local circuit temperature, TOFFSET** value. The **Circuit temperature**

value comes from the SPICE Environment Parameters block, if one exists in the circuit. Otherwise, it comes from the default value for this block.

- **Fixed temperature** — Use a temperature that is independent of the circuit temperature to model temperature dependence.

Offset local circuit temperature, TOFFSET

The amount by which the transistor temperature differs from the circuit temperature. This parameter is only visible when you select **Device temperature** for the **Model temperature dependence using** parameter. The default value is 0 K.

Fixed circuit temperature, TFIXED

The temperature at which to simulate the transistor. This parameter is only visible when you select **Fixed temperature** for the **Model temperature dependence using** parameter. The default value is 300.15 K. The value must be greater than 0.

Parameter extraction temperature, TMEAS

The temperature at which the transistor parameters were measured. The default value is 300.15 K. The value must be greater than 0.

Ports

The block has the following ports:

G

Electrical conserving port associated with the transistor gate terminal.

D

Electrical conserving port associated with the transistor drain terminal.

S

Electrical conserving port associated with the transistor source terminal.

PMOS

B

Electrical conserving port associated with the transistor bulk terminal.

References

[1] G. Massobrio and P. Antognetti. *Semiconductor Device Modeling with SPICE*. 2nd Edition, McGraw-Hill, 1993. Chapter 3.

See Also

NMOS

Purpose

Model Gummel-Poon PNP Transistor

Library

SPICE-Compatible Semiconductors

Description

The PNP block represents a SPICE-compatible four-terminal Gummel-Poon PNP transistor. The substrate port is connected to the transistor body using a capacitor, so these devices are equivalent to a three-terminal transistor when you connect the substrate port to any other port and use the default value of zero for the **C-S junction capacitance, CJS** parameter.

The PNP block model includes the following components:

- “Current-Voltage and Base Charge Model” on page 2-411
- “Base Resistance Model” on page 2-415
- “Transit Charge Modulation Model” on page 2-415
- “Junction Charge Model” on page 2-416
- “Temperature Dependence” on page 2-418

Current-Voltage and Base Charge Model

The current-voltage relationships and base charge relationships for the transistor are calculated after adjusting the applicable model parameters for temperature as described in the following sections:

- Emitter-Base and Collector-Base Junction Currents on page 411
- Terminal Currents on page 414
- Base Charge Model on page 414

Emitter-Base and Collector-Base Junction Currents

The base-emitter junction current is calculated using the following equations:

- When $V_{EB} > 80 * V_{TF}$:

$$I_{ebf} = IS * \left(\left(\frac{V_{EB}}{V_{TF}} - 79 \right) * e^{80} - 1 \right) + G_{\min} * V_{EB}$$

$$I_{ebe} = ISE * \left((V_{EB} - 80 * V_{TF} + V_{TE}) * \frac{e^{(80 * V_{TF} / V_{TE})}}{V_{TE}} - 1 \right)$$

- When $V_{EB} \leq 80 * V_{TF}$

$$I_{ebf} = IS * (e^{(V_{EB} / V_{TF})} - 1) + G_{\min} * V_{EB}$$

$$I_{ebe} = ISE * (e^{(V_{EB} / V_{TE})} - 1)$$

The base-collector junction current is calculated using the following equations:

- When $V_{CB} > 80 * V_{TR}$:

$$I_{cbr} = IS * \left(\left(\frac{V_{CB}}{V_{TR}} - 79 \right) * e^{80} - 1 \right) + G_{\min} * V_{CB}$$

$$I_{cbc} = ISC * \left((V_{CB} - 80 * V_{TR} + V_{TC}) * \frac{e^{(80 * V_{TR} / V_{TC})}}{V_{TC}} - 1 \right)$$

- When $V_{CB} \leq 80 * V_{TR}$

$$I_{cbr} = IS * (e^{(V_{CB} / V_{TR})} - 1) + G_{\min} * V_{CB}$$

$$I_{cbc} = ISC * (e^{(V_{CB} / V_{TC})} - 1)$$

In the preceding equations:

- V_{EB} is the emitter-base voltage and V_{CB} is the collector-base voltage.

$$V_{TE} = NE * k * T / q, V_{TC} = NC * k * T / q, V_{TF} = NF * k * T / q, \text{ and}$$

- $V_{TR} = NR * k * T / q$.
- ISC and ISE are the **B-C leakage current, ISC** and **B-E leakage current, ISE** parameter values, respectively.
- NE , NC , NF , and NR are the **B-E emission coefficient, NE**, **B-C emission coefficient, NC**, **Forward emission coefficient, NF** and **Reverse emission coefficient, NR** parameter values, respectively.
- q is the elementary charge on an electron.
- k is the Boltzmann constant.
- T is the transistor temperature:
 - If you select `Device` temperature for the **Model temperature dependence using** parameter, T is the sum of the **Circuit temperature** value plus the **Offset local circuit temperature, TOFFSET** parameter value. The **Circuit temperature** value comes from the SPICE Environment Parameters block, if one exists in the circuit. Otherwise, it comes from the default value for this block.
 - If you select `Fixed` temperature for the **Model temperature dependence using** parameter, T is the **Fixed circuit temperature, TFIXED** parameter value.
- G_{min} is the minimum conductance. By default, G_{min} matches the **Minimum conductance GMIN** parameter of the SPICE Environment Parameters block, whose default value is 1e-12. To change G_{min} , add a SPICE Environment Parameters block to your model and set the **Minimum conductance GMIN** parameter to the desired value.

Terminal Currents

The terminal currents, I_B and I_C are the base and collector currents, defined as positive into the device. They are calculated as:

$$I_B = - \left(\frac{I_{ebf}}{BF} + I_{ebe} + \frac{I_{cbr}}{BR} + I_{cbc} \right)$$

$$I_C = - \left(\frac{I_{ebf} - I_{cbr}}{q_b} - \frac{I_{cbr}}{BR} - I_{cbc} \right)$$

where BF and BR are the **Forward beta, BF** and **Reverse beta, BR** parameter values, respectively.

Base Charge Model

The base charge, q_b , is calculated using the following equations:

$$q_b = \frac{q_1}{2} \left(1 + \sqrt{0.5 * \left(\sqrt{(1 + 4 * q_2 - eps)^2 + eps^2} + 1 + 4 * q_2 - eps \right) + eps} \right)$$

$$q_1 = \left(1 - \frac{V_{CB}}{VAF} - \frac{V_{EB}}{VAR} \right)^{-1}$$

$$q_2 = \frac{I_{ebf}}{IKF} + \frac{I_{cbr}}{IKR}$$

where

- VAF and VAR are the **Forward Early voltage, VAF** and **Reverse Early voltage, VAR** parameters, respectively.
- IKF and IKR are the **Forward knee current, IKF** and **Reverse knee current, IKR** parameter values, respectively.
- eps is 1e-4.

Base Resistance Model

The block models base resistance in one of two ways:

- If you use the default value of infinity for the **Half base resistance cur, IRB** parameter, the PNP block calculates the base resistance r_{bb} as

$$r_{bb} = RBM + \frac{RB - RBM}{q_b}$$

where:

- RBM is the **Minimum base resistance, RBM** parameter value.
- RB is the **Zero-bias base resistance, RB** parameter value.
- If you specify a finite value for the **Half base resistance cur, IRB** parameter, the PNP block calculates the base resistance r_{bb} as

$$r_{bb} = RBM + 3 * (RB - RBM) * \left(\frac{\tan z - z}{z * \tan^2 z} \right)$$

where:

$$z = \frac{\sqrt{1 + 144I_B / (\pi^2 IRB)} - 1}{(24 / \pi^2) \sqrt{(I_B / IRB)}}$$

Transit Charge Modulation Model

If you specify nonzero values for the **Coefficient of TF, XTF** parameter, the block models transit charge modulation by scaling the **Forward transit time, TF** parameter value as follows:

$$TF_{\text{mod}} = \frac{TF * \left[1 + XTF * e^{V_{CB}/(1.44V_{TF})} \left(\frac{I_{EB}}{I_{EB} + ITF} \right)^2 \right]}{q_b}$$

where ITF is the **Coefficient of TF**, ITF parameter value.

Junction Charge Model

The PNP block lets you model junction charge. The collector-base charge Q_{cb} and the emitter-base charge Q_{eb} depend on an intermediate value, Q_{dep} as follows, after adjusting the applicable model parameters for temperature:

- For the internal base-emitter junctions:

$$Q_{eb} = TF_{\text{mod}} * I_{eb} + Q_{dep}$$

- For the internal base-collector junctions:

$$Q_{cb} = TR * I_{cb} + XCJC * Q_{dep}$$

- For the external base-collector junctions:

$$Q_{cb_{\text{ext}}} = (1 - XCJC) * Q_{dep}$$

Q_{dep} depends on the junction voltage, V_{jct} (V_{EB} for the emitter-base junction and V_{CB} for the collector-base junction) as follows.

Applicable Range of V_{jct} Values	Corresponding Q_{dep} Equation
$V_{jct} < FC * VJ$	$Q_{dep} = C_{jct} * VJ * \frac{1 - (1 - V_{jct}/VJ)^{(1-MJ)}}{1 - MJ}$
$V_{jct} \geq FC * VJ$	$Q_{dep} = C_{jct} * \left[F1 + \frac{F3 * (V_{jct} - FC * VJ) + \frac{MJ * [V_{jct}^2 - (FC * VJ)^2]}{2 * VJ}}{F2} \right]$

Where:

- FC is the **Capacitance coefficient FC** parameter value.
- VJ is:
 - The **B-E built-in potential, VJE** parameter value for the emitter-base junction.
 - The **B-C built-in potential, VJC** parameter value for the collector-base junction.
- MJ is:
 - The **B-E exponential factor, MJE** parameter value for the emitter-base junction.
 - The **B-C exponential factor, MJC** parameter value for the collector-base junction.
- C_{jct} is:
 - The **B-E depletion capacitance, CJE** parameter value for the emitter-base junction.

- The **B-C depletion capacitance, CJC** parameter value for the collector-base junction.

- $F1 = VJ * \left(1 - (1 - FC)^{(1-MJ)}\right) / (1 - MJ)$
- $F2 = (1 - FC)^{(1+MJ)}$
- $F3 = 1 - FC * (1 + MJ)$

The collector-substrate charge Q_{sc} depends on the collector-substrate voltage V_{sc} as follows, after adjusting the applicable model parameters for temperature.

Applicable Range of V_{sc} Values	Corresponding Q_{sc} Equation
$V_{sc} < 0$	$Q_{sc} = CJS * VJS * \left(\frac{1 - (1 - V_{sc}/VJS)^{(1-MJS)}}{1 - MJS} \right)$
$V_{sc} \geq 0$	$Q_{sc} = CJS * (1 + MJS * V_{sc} / (2 * VJS)) * V_{sc}$

where:

- CJS is the **C-S junction capacitance, CJS** parameter value.
- VJS is the **Substrate built-in potential, VJS** parameter value.
- MJS is the **Substrate exponential factor, MJS** parameter value.

Temperature Dependence

Several transistor parameters depend on temperature. There are two ways to specify the transistor temperature:

- When you select `Device` temperature for the **Model temperature dependence using** parameter, the transistor temperature is

$$T = T_C + T_O$$

where:

- T_C is the **Circuit temperature** parameter value from the SPICE Environment Parameters block. If this block doesn't exist in the circuit, T_C is the default value of this parameter.
 - T_O is the **Offset local circuit temperature, TOFFSET** parameter value.
- When you select `Fixed` temperature for the **Model temperature dependence using** parameter, the transistor temperature is the **Fixed circuit temperature, TFIXED** parameter value.

The block provides the following relationship between the saturation current IS and the transistor temperature T :

$$IS(T) = IS * (T/T_{meas})^{XTI} * e^{\left(\frac{T}{T_{meas}} - 1\right) * \frac{EG}{V_t}}$$

where:

- IS is the **Transport saturation current, IS** parameter value.
- T_{meas} is the **Parameter extraction temperature, TMEAS** parameter value.
- XTI is the **Temperature exponent for IS, XTI** parameter value.
- EG is the **Energy gap, EG** parameter value.
- $V_t = kT/q$.

The block provides the following relationship between the base-emitter junction potential V_{JE} and the transistor temperature T :

$$VJE(T) = VJE * \left(\frac{T}{T_{meas}} \right) - \frac{3 * k * T}{q} * \log \left(\frac{T}{T_{meas}} \right) - \left(\frac{T}{T_{meas}} \right) * EG_{T_{meas}} + EG_T$$

where:

- VJE is the **B-E built-in potential**, **VJE** parameter value.
- $EG_{T_{meas}} = 1.16eV - (7.02e - 4 * T_{meas}^2) / (T_{meas} + 1108)$
- $EG_T = 1.16eV - (7.02e - 4 * T^2) / (T + 1108)$

The block uses the $VJE(T)$ equation to calculate the base-collector junction potential by substituting VJC (the **B-C built-in potential**, **VJC** parameter value) for VJE .

The block provides the following relationship between the base-emitter junction capacitance CJE and the transistor temperature T :

$$CJE(T) = CJE * \left[1 + MJE * \left(400e - 6 * (T - T_{meas}) - \frac{VJE(T) - VJE}{VJE} \right) \right]$$

where:

- CJE is the **B-E depletion capacitance**, **CJE** parameter value.
- MJE is the **B-E exponential factor**, **MJE** parameter value.

The block uses this equation to calculate the base-collector junction capacitance by substituting CJC (the **B-C depletion capacitance**, **CJC** parameter value) for CJE and MJC (the **B-C exponential factor**, **MJC** parameter value) for MJE .

The block provides the following relationship between the forward and reverse beta and the transistor temperature T :

$$\beta(T) = \beta * \left(\frac{T}{T_{meas}} \right)^{XTB}$$

where:

- β is the **Forward beta, BF** or **Reverse beta, BR** parameter value.
- XTB is the **Beta temperature exponent, XTB** parameter value.

The block provides the following relationship between the base-emitter leakage current ISE and the transistor temperature T :

$$ISE(T) = ISE * \left(\frac{T}{T_{meas}} \right)^{-XTB} * \left(\frac{IS(T)}{IS} \right)^{1/NE}$$

where:

- ISE is the **B-E leakage current, ISE** parameter value.
- NE is the **B-E emission coefficient, NE** parameter value.

The block uses this equation to calculate the base-collector leakage current by substituting ISC (the **B-C leakage current, ISC** parameter value) for ISE and NC (the **B-C emission coefficient, NC** parameter value) for NE .

Basic Assumptions and Limitations

The model is based on the following assumptions:

- The PNP block does not support noise analysis.
- The PNP block applies initial conditions across junction capacitors and not across the block ports.

Dialog Box and Parameters

Main Tab

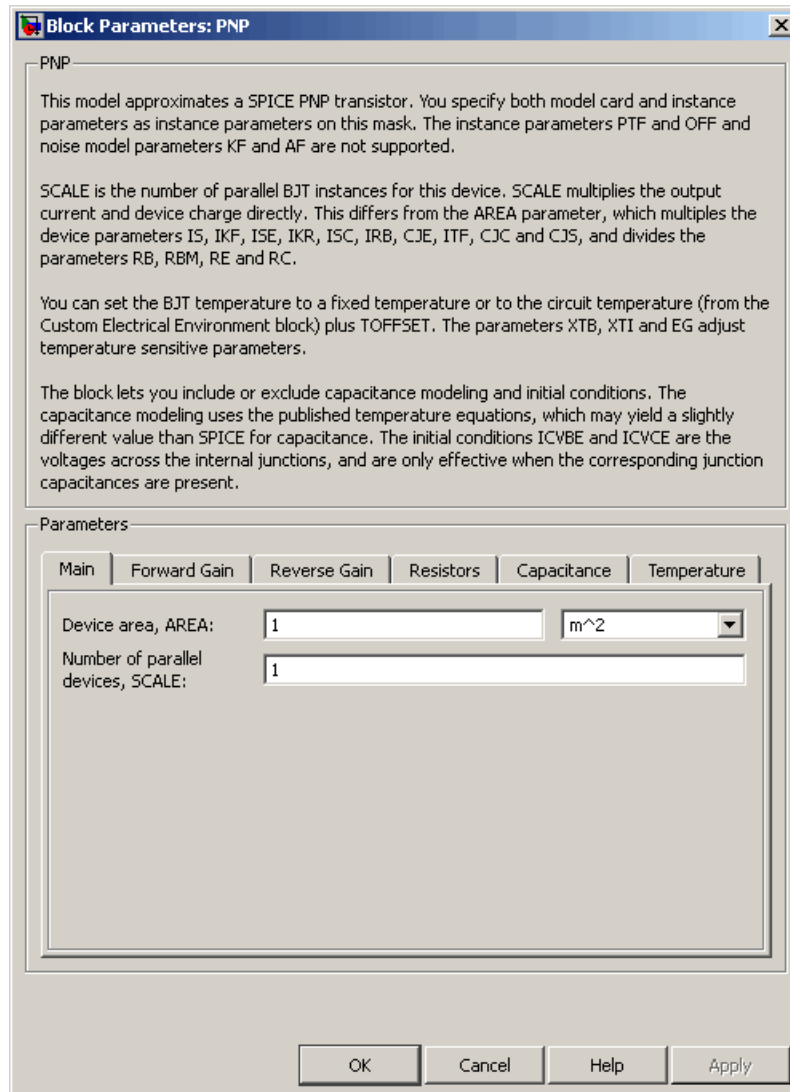

Device area, AREA

The transistor area. This value multiplies the following parameter values:

- **Transport saturation current, IS**
- **Forward knee current, IKF**
- **B-E leakage current, ISE**
- **Reverse knee current, IKR**
- **B-C leakage current, ISC**
- **Half base resistance cur, IRB**
- **B-E depletion capacitance, CJE**
- **Coefficient of TF, ITF**
- **B-C depletion capacitance, CJC**
- **C-S junction capacitance, CJS**

It divides the following parameter values:

- **Zero-bias base resistance, RB**
- **Minimum base resistance, RBM**
- **Emitter resistance, RE**
- **Collector resistance, RC**

The default value is 1 m². The value must be greater than 0.

Number of parallel devices, SCALE

The number of parallel transistors the block represents. This value multiplies the output current and device charges. The default value is 1. The value must be greater than 0.

Forward Gain Tab

Block Parameters: PNP
X

PNP

This model approximates a SPICE PNP transistor. You specify both model card and instance parameters as instance parameters on this mask. The instance parameters PTF and OFF and noise model parameters KF and AF are not supported.

SCALE is the number of parallel BJT instances for this device. SCALE multiplies the output current and device charge directly. This differs from the AREA parameter, which multiplies the device parameters IS, IKF, ISE, IKR, ISC, IRB, CJE, ITF, CJC and CJS, and divides the parameters RB, RBM, RE and RC.

You can set the BJT temperature to a fixed temperature or to the circuit temperature (from the Custom Electrical Environment block) plus TOFFSET. The parameters XTB, XTI and EG adjust temperature sensitive parameters.

The block lets you include or exclude capacitance modeling and initial conditions. The capacitance modeling uses the published temperature equations, which may yield a slightly different value than SPICE for capacitance. The initial conditions ICVBE and ICVCE are the voltages across the internal junctions, and are only effective when the corresponding junction capacitances are present.

Parameters

Main
Forward Gain
Reverse Gain
Resistors
Capacitance
Temperature

Transport saturation current, IS:	<input style="width: 100%;" type="text" value="1e-16"/>	<input style="width: 100%;" type="text" value="A/m^2"/>
Forward beta, BF:	<input style="width: 100%;" type="text" value="100"/>	
Forward emission coefficient, NF:	<input style="width: 100%;" type="text" value="1"/>	
B-E leakage current, ISE:	<input style="width: 100%;" type="text" value="0"/>	<input style="width: 100%;" type="text" value="A/m^2"/>
B-E emission coefficient, NE:	<input style="width: 100%;" type="text" value="1.5"/>	
Forward knee current, IKF:	<input style="width: 100%;" type="text" value="Inf"/>	<input style="width: 100%;" type="text" value="A/m^2"/>
Forward Early voltage, VAF:	<input style="width: 100%;" type="text" value="Inf"/>	<input style="width: 100%;" type="text" value="V"/>

Transport saturation current, IS

The magnitude of the current at which the transistor saturates. The default value is $1e-16$ A/m². The value must be greater than or equal to 0.

Forward beta, BF

The ideal maximum reverse beta. The default value is 100. The value must be greater than 0.

Forward emission coefficient, NF

The reverse emission coefficient or ideality factor. The default value is 1. The value must be greater than 0.

B-E leakage current, ISE

The base-emitter leakage current. The default value is 0 A/m². The value must be greater than or equal to 0.

B-E emission coefficient, NE

The base-collector emission coefficient or ideality factor. The default value is 1.5. The value must be greater than 0.

Forward knee current, IKF

The current value at which forward-beta high-current roll-off occurs. The default value is 0 A/m². The value must be greater than or equal to 0. For this parameter, the software interprets a value of 0 as infinity.

Forward Early voltage, VAF

The forward Early voltage. The default value is 0 V. The value must be greater than or equal to 0. For this parameter, the software interprets a value of 0 as infinity.

Reverse Gain Tab

Block Parameters: PNP
X

PNP

This model approximates a SPICE PNP transistor. You specify both model card and instance parameters as instance parameters on this mask. The instance parameters PTF and OFF and noise model parameters KF and AF are not supported.

SCALE is the number of parallel BJT instances for this device. SCALE multiplies the output current and device charge directly. This differs from the AREA parameter, which multiplies the device parameters IS, IKF, ISE, IKR, ISC, IRB, CJE, ITF, CJC and CJS, and divides the parameters RB, RBM, RE and RC.

You can set the BJT temperature to a fixed temperature or to the circuit temperature (from the Custom Electrical Environment block) plus TOFFSET. The parameters XTB, XTI and EG adjust temperature sensitive parameters.

The block lets you include or exclude capacitance modeling and initial conditions. The capacitance modeling uses the published temperature equations, which may yield a slightly different value than SPICE for capacitance. The initial conditions ICVBE and ICVCE are the voltages across the internal junctions, and are only effective when the corresponding junction capacitances are present.

Parameters

Main	Forward Gain	Reverse Gain	Resistors	Capacitance	Temperature
Reverse beta, BR:					
<input style="width: 90%;" type="text" value="1"/>					
Reverse emission coefficient, NR:					
<input style="width: 90%;" type="text" value="1"/>					
B-C leakage current, ISC:					
<input style="width: 90%;" type="text" value="0"/>				<input style="width: 100%;" type="text" value="A/m^2"/>	
B-C emission coefficient, NC:					
<input style="width: 90%;" type="text" value="2"/>					
Reverse knee current, IKR:					
<input style="width: 90%;" type="text" value="Inf"/>				<input style="width: 100%;" type="text" value="A/m^2"/>	
Reverse Early voltage, VAR:					
<input style="width: 90%;" type="text" value="Inf"/>				<input style="width: 100%;" type="text" value="V"/>	

Reverse beta, BR

The ideal maximum reverse beta. The default value is 1. The value must be greater than 0.

Reverse emission coefficient, NR

The reverse emission coefficient or ideality factor. The default value is 1. The value must be greater than 0.

B-C leakage current, ISC

The base-collector leakage current. The default value is 0 A/m². The value must be greater than or equal to 0.

B-C emission coefficient, NC

The base-collector emission coefficient or ideality factor. The default value is 2. The value must be greater than 0.

Reverse knee current, IKR

The current value at which reverse-beta high-current roll-off occurs. The default value is 0 A/m². The value must be greater than or equal to 0. For this parameter, the software interprets a value of 0 as infinity.

Reverse Early voltage, VAR

The reverse Early voltage. The default value is 0 V. The value must be greater than or equal to 0. For this parameter, the software interprets a value of 0 as infinity.

Resistors Tab

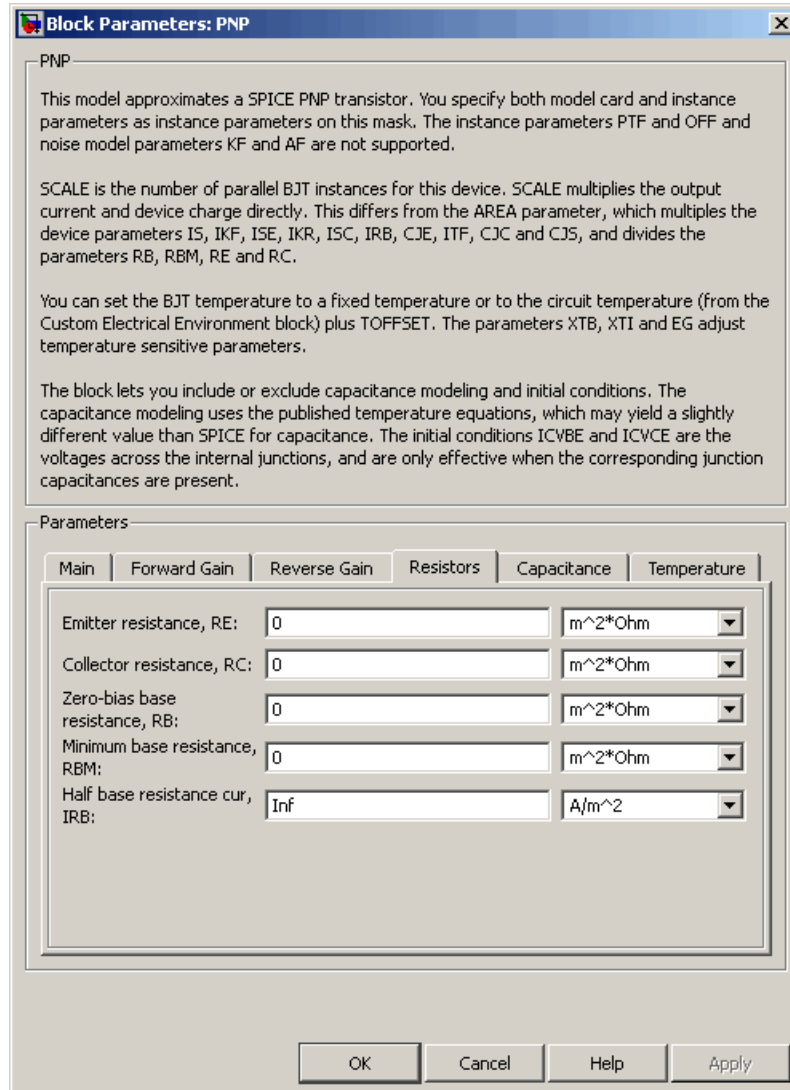

Emitter resistance, RE

The resistance of the emitter. The default value is $0 \text{ m}^2 \cdot \Omega$. The value must be greater than or equal to 0.

Collector resistance, RC

The resistance of the collector. The default value is $0 \text{ m}^2 \cdot \Omega$. The value must be greater than or equal to 0.

Zero-bias base resistance, RB

The resistance of the collector. The default value is $0 \text{ m}^2 \cdot \Omega$. The value must be greater than or equal to 0.

Minimum base resistance, RBM

The resistance of the collector. The default value is $0 \text{ m}^2 \cdot \Omega$. The value must be less than or equal to the **Zero-bias base resistance, RB** parameter value.

Half base resistance cur, IRB

The base current at which the base resistance has dropped to half of its zero-bias value. The default value is Inf A/m^2 . The value must be greater than or equal to 0. Use the default value of Inf if you do not want to model the change in base resistance as a function of base current.

Capacitance Tab

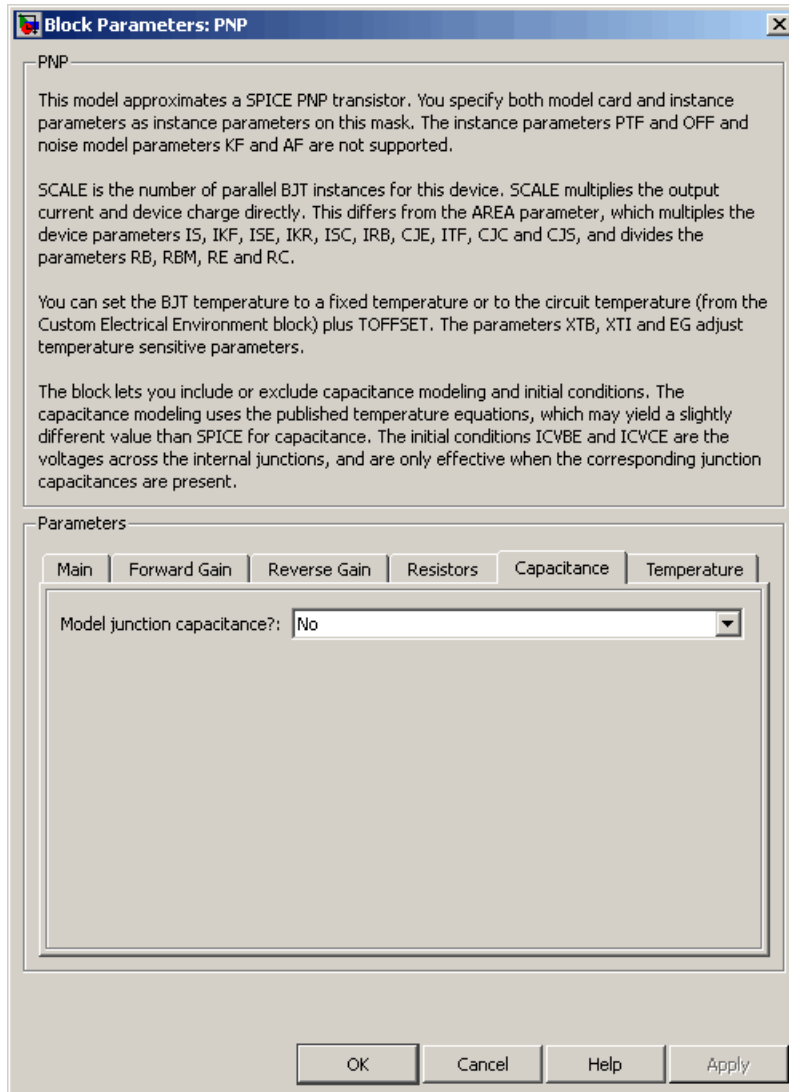

Model junction capacitance

Select one of the following options for modeling the junction capacitance:

- **No** — Do not include junction capacitance in the model. This is the default option.
- **B-E Capacitance** — Model the junction capacitance across the base-emitter junction.
- **B-C Capacitance** — Model the junction capacitance across the base-collector junction.
- **C-S Capacitance** — Model the junction capacitance across the collector-substrate junction.

Note To include junction capacitance in the model:

- 1** Select **B-E Capacitance** and specify the base-emitter junction capacitance parameters.
- 2** Select **B-C Capacitance** and specify the base-collector junction capacitance parameters.
- 3** Select **C-S Capacitance** and specify the collector-substrate junction capacitance parameters.

You can specify or change any of the common parameters when you select any of the preceding options for the **Model junction capacitance** parameter.

B-E depletion capacitance, CJE

The depletion capacitance across the base-emitter junction. This parameter is only visible when you select **B-E Capacitance** for the **Model junction capacitance** parameter. The default value is 0 F/m². The value must be greater than or equal to 0.

B-E built-in potential, VJE

The base-emitter junction potential. This parameter is only visible when you select B-E Capacitance for the **Model junction capacitance** parameter. The default value is 0.75 V. The value must be greater than or equal to 0.01 V.

B-E exponential factor, MJE

The grading coefficient for the base-emitter junction. This parameter is only visible when you select B-E Capacitance for the **Model junction capacitance** parameter. The default value is 0.33. The value must be greater than or equal to 0 and less than or equal to 0.9.

Forward transit time, TF

The transit time of the minority carriers that cause diffusion capacitance when the base-emitter junction is forward-biased. This parameter is only visible when you select B-E Capacitance for the **Model junction capacitance** parameter. The default value is 0. The value must be greater than or equal to 0.

Coefficient of TF, XTF

The coefficient for the base-emitter and base-collector bias dependence of the transit time, which produces a charge across the base-emitter junction. This parameter is only visible when you select B-E Capacitance for the **Model junction capacitance** parameter. The default value is 0. The value must be greater than or equal to 0. Use the default value of 0 if you do not want to model the effect of base-emitter bias on transit time.

VBC dependence of TF, VTF

The coefficient for the base-emitter bias dependence of the transit time. This parameter is only visible when you select B-E Capacitance for the **Model junction capacitance** parameter. The default value is 0 V. The value must be greater than or equal to 0. For this parameter, the software interprets a value of 0 as infinity.

Coefficient of TF, ITF

The coefficient for the dependence of the transit time on collector current. This parameter is only visible when you select **B-E Capacitance** for the **Model junction capacitance** parameter. The default value is 0 A/m². The value must be greater than or equal to 0. Use the default value of 0 if you do not want to model the effect of collector current on transit time.

B-C depletion capacitance, CJC

The depletion capacitance across the base-collector junction. This parameter is only visible when you select **B-C Capacitance** for the **Model junction capacitance** parameter. The default value is 0 F/m². The value must be greater than 0.

B-C built-in potential, VJC

The base-collector junction potential. This parameter is only visible when you select **B-C Capacitance** for the **Model junction capacitance** parameter. The default value is 0.75 V. The value must be greater than or equal to 0.01 V.

B-C exponential factor, MJC

The grading coefficient for the base-collector junction. This parameter is only visible when you select **B-C Capacitance** for the **Model junction capacitance** parameter. The default value is 0.33. The value must be greater than or equal to 0 and less than or equal to 0.9.

B-C capacitance fraction, XCJC

The fraction of the base-collector depletion capacitance that is connected between the internal base and the internal collector. The rest of the base-collector depletion capacitance is connected between the external base and the internal collector. This parameter is only visible when you select **B-C Capacitance** for the **Model junction capacitance** parameter. The default value is 0. The value must be greater than or equal to 0 and less than or equal to 1.

Reverse transit time, TR

The transit time of the minority carriers that cause diffusion capacitance when the base-collector junction is reverse-biased. This parameter is only visible when you select B-C Capacitance for the **Model junction capacitance** parameter. The default value is 0 s. The value must be greater than or equal to 0.

Capacitance coefficient FC

The fitting coefficient that quantifies the decrease of the depletion capacitance with applied voltage. This parameter is only visible when you select B-E Capacitance or B-C Capacitance for the **Model junction capacitance** parameter. The default value is 0.5. The value must be greater than or equal to 0 and less than or equal to 0.95.

Specify initial condition

Select one of the following options for specifying an initial condition:

- No — Do not specify an initial condition for the model. This is the default option.
- Yes — Specify the initial transistor conditions.

Note The PNP block applies the initial transistor voltages across the junction capacitors and not across the ports.

This parameter is only visible when you select B-E Capacitance or B-C Capacitance for the **Model junction capacitance** parameter.

Initial condition voltage ICVBE

Base-emitter voltage at the start of the simulation. This parameter is only visible when you select B-E Capacitance or B-C Capacitance for the **Model junction capacitance** and Yes for the **Specify initial condition** parameter. The default value is 0 V.

Initial condition voltage ICVCE

Base-collector voltage at the start of the simulation. This parameter is only visible when you select B-E Capacitance or B-C Capacitance for the **Model junction capacitance** and Yes for the **Specify initial condition** parameter. The default value is 0 V.

C-S junction capacitance, CJS

The collector-substrate junction capacitance. This parameter is only visible when you select C-S Capacitance for the **Model junction capacitance** parameter. The default value is 0 F/m². The value must be greater than or equal to 0.

Substrate built-in potential, VJS

The potential of the substrate. This parameter is only visible when you select C-S Capacitance for the **Model junction capacitance** parameter. The default value is 0.75 V.

Substrate exponential factor, MJS

The grading coefficient for the collector-substrate junction. This parameter is only visible when you select C-S Capacitance for the **Model junction capacitance** parameter. The default value is 0. The value must be greater than or equal to 0 and less than or equal to 0.9.

Temperature Tab

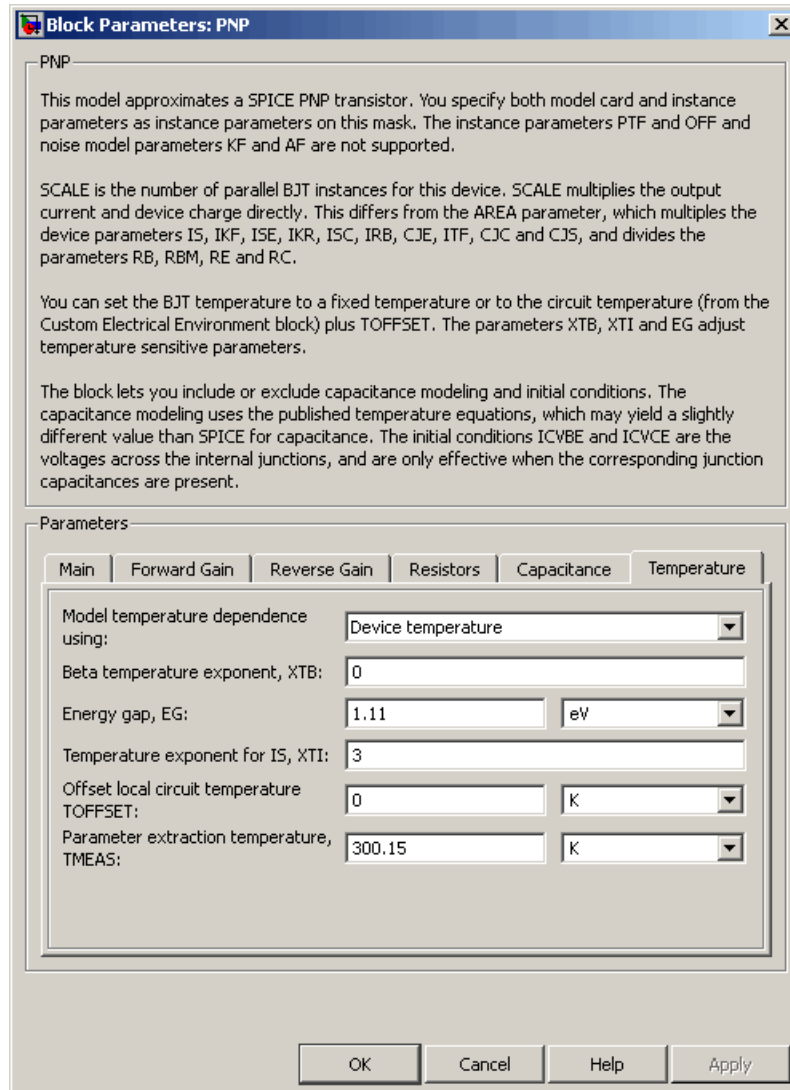

Model temperature dependence using

Select one of the following options for modeling the transistor temperature dependence:

- **Device temperature** — Use the device temperature, which is the **Circuit temperature** value plus the **Offset local circuit temperature, TOFFSET** value. The **Circuit temperature** value comes from the SPICE Environment Parameters block, if one exists in the circuit. Otherwise, it comes from the default value for this block.
- **Fixed temperature** — Use a temperature that is independent of the circuit temperature to model temperature dependence.

Beta temperature exponent, XTB

The forward and reverse beta temperature exponent that models base current temperature dependence. This parameter is only visible when you select **Device temperature** for the **Model temperature dependence using** parameter. The default value is 0. The value must be greater than or equal to 0.

Energy gap, EG

The energy gap that affects the increase in the saturation current as temperature increases. This parameter is only visible when you select **Device temperature** for the **Model temperature dependence using** parameter. The default value is 1.11 eV. The value must be greater than or equal to 0.1.

Temperature exponent for IS, XTI

The order of the exponential increase in the saturation current as temperature increases. This parameter is only visible when you select **Device temperature** for the **Model temperature dependence using** parameter. The default value is 3. The value must be greater than or equal to 0.

Offset local circuit temperature, TOFFSET

The amount by which the transistor temperature differs from the circuit temperature. This parameter is only visible when you select **Device temperature** for the **Model temperature dependence using** parameter. The default value is 0 K.

Parameter extraction temperature, TMEAS

The temperature at which the transistor parameters were measured. The default value is 300.15 K. The value must be greater than 0.

Fixed circuit temperature, TFIXED

The temperature at which to simulate the transistor. This parameter is only visible when you select `Fixed temperature` for the **Model temperature dependence using** parameter. The default value is 300.15 K. The value must be greater than 0.

Ports

The block has the following ports:

B

Electrical conserving port associated with the transistor base terminal.

C

Electrical conserving port associated with the transistor collector terminal.

E

Electrical conserving port associated with the transistor emitter terminal.

S

Electrical conserving port associated with the transistor substrate terminal.

References

[1] G. Massobrio and P. Antognetti. *Semiconductor Device Modeling with SPICE*. 2nd Edition, McGraw-Hill, 1993. Chapter 2.

See Also

Generic Linear Actuator

Purpose

Model PNP bipolar transistor using enhanced Ebers-Moll equations

Library

Semiconductor Devices

Description



PNP Bipolar Transistor

The PNP Bipolar Transistor block uses a variant of the Ebers-Moll equations to represent an PNP bipolar transistor. The Ebers-Moll equations are based on two exponential diodes plus two current-controlled current sources. The PNP Bipolar Transistor block provides the following enhancements to that model:

- Early voltage effect
- Optional base, collector, and emitter resistances.
- Optional fixed base-emitter and base-collector capacitances.

The collector and base currents are [1]:

$$I_C = -I_S \left[\left(e^{-qV_{BE}/(kT)} - e^{-qV_{BC}/(kT)} \right) \left(1 + \frac{V_{BC}}{V_A} \right) - \frac{1}{\beta_R} \left(e^{-qV_{BC}/(kT)} - 1 \right) \right]$$
$$I_B = -I_S \left[\frac{1}{\beta_F} \left(e^{-qV_{BE}/(kT)} - 1 \right) + \frac{1}{\beta_R} \left(e^{-qV_{BC}/(kT)} - 1 \right) \right]$$

Where:

- I_B and I_C are base and collector currents, defined as positive into the device.
- V_{be} is the base-emitter voltage and V_{bc} is the base-collector voltage.
- β_F is the ideal maximum current gain BF
- β_R is the ideal maximum current gain BR
- V_A is the forward Early voltage VAF
- q is the elementary charge on an electron (1.602176e-19 Coulombs).
- k is the Boltzmann constant (1.3806503e-23 J/K).

PNP Bipolar Transistor

- T is the transistor temperature, as defined by the **Measurement temperature** parameter value.

You can specify the transistor behavior using datasheet parameters that the block uses to calculate the parameters for these equations, or you can specify the equation parameters directly.

If $-qV_{BC}/(kT) > 40$ or $-qV_{BE}/(kT) > 40$, the corresponding exponential terms in the equations are replaced with

$(-qV_{BC}/(kT) - 39)e^{40}$ and $(-qV_{BE}/(kT) - 39)e^{40}$, respectively.

This helps prevent numerical issues associated with the steep gradient of the exponential function e^x at large values of x .

Similarly, if $-qV_{BC}/(kT) < -39$ or $-qV_{BE}/(kT) < -39$ then the corresponding exponential terms in the equations are replaced with

$(-qV_{BC}/(kT) + 40)e^{-39}$ and $(-qV_{BE}/(kT) + 40)e^{-39}$, respectively.

Optionally, you can specify parasitic fixed capacitances across the base-emitter and base-collector junctions. You also have the option to specify base, collector, and emitter connection resistances.

Basic Assumptions and Limitations

The PNP Bipolar Transistor model has the following limitations:

- This block does not model temperature-dependent effects. SimElectronics simulates the block at the temperature at which the component behavior was measured, as specified by the **Measurement temperature** parameter value.
- You may need to use nonzero ohmic resistance and junction capacitance values to prevent numerical simulation issues, but the simulation may run faster with these values set to zero.

Dialog Box and Parameters

Main Tab

Block Parameters: PNP Bipolar Transistor

PNP Bipolar Transistor

This block represents a PNP transistor modeled using a variant of the Ebers-Moll equations. The Ebers-Moll equations are based on two exponential diodes plus two current-controlled current sources. In addition, this block adds the Early voltage effect, and gives the option to include base, emitter and emitter resistances plus fixed base-emitter and base-collector capacitances. For full details of the equations, consult the documentation. The equation parameters can either be specified directly, or are derived from standard datasheet parameters.

Parameters

Main | Ohmic Resistance | Junction Capacitance

Parameterization: Specify from a datasheet

Forward current transfer ratio h_{fe} : 100

Output admittance h_{oe} : 5e-05 1/Ohm

Collector current at which h-parameters are defined: 1 mA

Voltage V_{be} : 0.55 V

Current I_b for voltage V_{be} : 0.5 mA

Reverse current transfer ratio BR: 1

Measurement temperature: 25 C

OK Cancel Help Apply

Parameterization

Select one of the following methods for block parameterization:

- **Specify from a datasheet** — Provide parameters that the block converts to equations that describe the transistor. The block calculates the forward Early voltage VAF as I_c/h_{oe} , where I_c is the **Collector current at which h-parameters are defined** parameter value, and h_{oe} is the **Output**

PNP Bipolar Transistor

admittance h_{oe} parameter value [2]. The block sets BF to the small-signal **Forward current transfer ratio h_{fe}** value. The block calculates the saturation current IS from the specified **Voltage V_{be}** value and the corresponding **Current I_b for voltage V_{be}** value when I_c is zero. This is the default method.

- Specify using equation parameters directly — Provide equation parameters IS , BF , and VAF .

Forward current transfer ratio h_{fe}

Small-signal current gain. This parameter is only visible when you select **Specify** from a datasheet for the **Parameterization** parameter. The default value is 100.

Output admittance h_{oe}

Derivative of the collector current with respect to the collector-emitter voltage for a fixed base current. This parameter is only visible when you select **Specify** from a datasheet for the **Parameterization** parameter. The default value is $5e-05$ 1/ Ω .

Collector current at which h-parameters are defined

The h-parameters vary with operating point, and are defined for this value of the collector current. This parameter is only visible when you select **Specify** from a datasheet for the **Parameterization** parameter. The default value is 1 mA.

Voltage V_{be}

Base-emitter voltage when the collector current is zero and the base current is I_b . This parameter is only visible when you select **Specify** from a datasheet for the **Parameterization** parameter. The default value is 0.55 V.

Current I_b for voltage V_{be}

Base current when the base-emitter voltage is V_{be} and the collector current is zero. This parameter is only visible when you select **Specify** from a datasheet for the **Parameterization** parameter. The default value is 0.5 mA.

Forward current transfer ratio BF

Ideal maximum forward current gain. This parameter is only visible when you select **Specify using equation parameters** directly for the **Parameterization** parameter. The default value is 100.

Saturation current IS

Transistor saturation current. This parameter is only visible when you select **Specify using equation parameters** directly for the **Parameterization** parameter. The default value is $1e-14$ A.

Forward Early voltage VAF

In the standard Ebers-Moll equations, the gradient of the I_c versus V_{ce} curve is zero in the normal active region. The additional forward Early voltage term increases this gradient. The intercept on the V_{ce} -axis is equal to $-VAF$ when the linear region is extrapolated. This parameter is only visible when you select **Specify using equation parameters** directly for the **Parameterization** parameter. The default value is 200 V.

Reverse current transfer ratio BR

Ideal maximum reverse current gain. This value is often not quoted in manufacturer datasheets because it is not significant when the transistor is biased to operate in the normal active region. When the value is not known and the transistor is not to be operated on the inverse region, use the default value of 1.

Measurement temperature

Temperature at which V_{be} and I_b or IS are measured. This parameter is only visible when you select **Specify** from a datasheet for the **Parameterization** parameter. The default value is 25 °C.

PNP Bipolar Transistor

Ohmic Resistance Tab

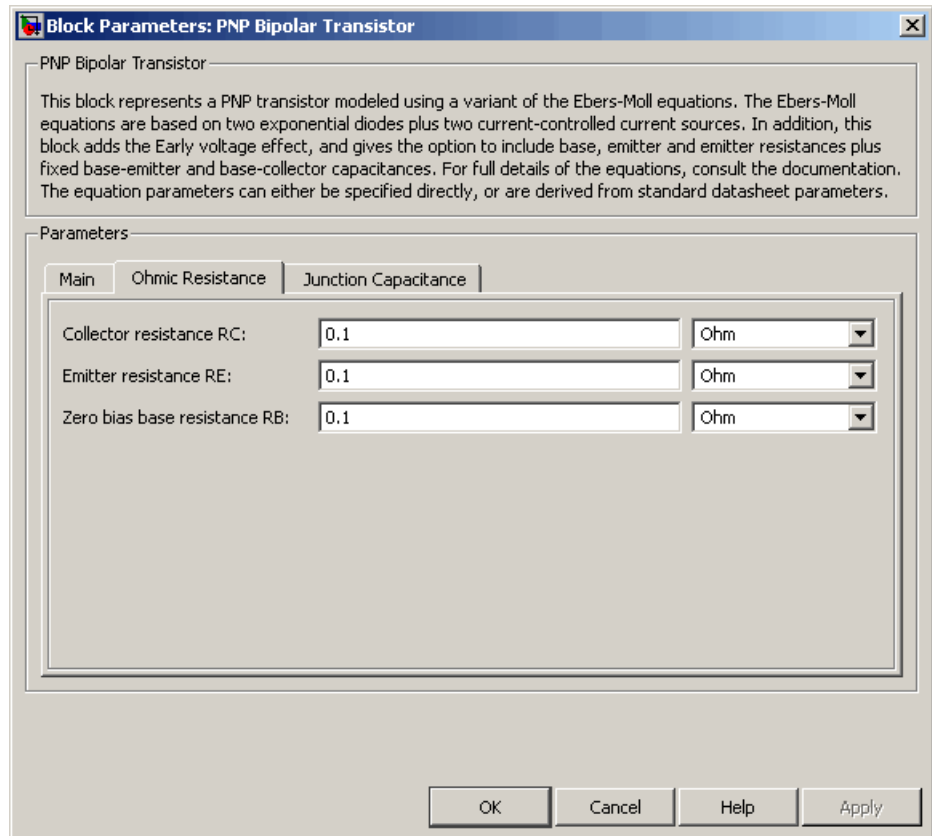

Collector resistance RC

Resistance at the collector. The default value is 0.1 Ω .

Emitter resistance RE

Resistance at the emitter. The default value is 0.1 Ω .

Zero bias base resistance RB

Resistance at the base at zero bias. The default value is 0.1 Ω .

Junction Capacitance Tab

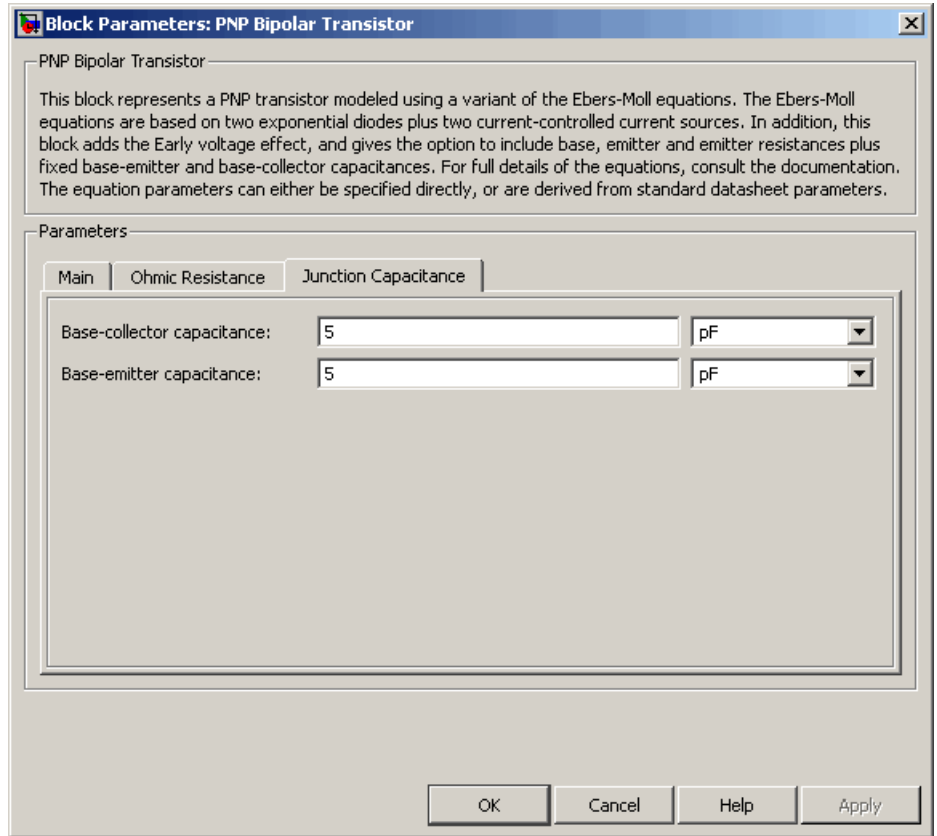

Base-collector capacitance

Parasitic capacitance across the base-collector junction. The default value is 5 pF.

Base-emitter capacitance

Parasitic capacitance across the base-emitter junction. The default value is 5 pF.

PNP Bipolar Transistor

Ports

The block has the following ports:

B

Electrical conserving port associated with the transistor base terminal.

C

Electrical conserving port associated with the transistor collector terminal.

E

Electrical conserving port associated with the transistor emitter terminal.

Examples

See the Bipolar Transistor Characteristics demo.

References

[1] G. Massobrio and P. Antognetti. *Semiconductor Device Modeling with SPICE*. 2nd Edition, McGraw-Hill, 1993.

[2] H. Ahmed and P.J. Spreadbury. *Analogue and digital electronics for engineers*. 2nd Edition, Cambridge University Press, 1984.

See Also

Diode, NPN Bipolar Transistor

Purpose Model ideal positive supply rail

Library Sources

Description

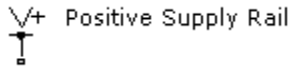

The Positive Supply Rail block represents an ideal positive supply rail. Use this block instead of the Simscape DC Voltage Source block to define the output voltage relative to the Simscape Electrical Reference block that must appear in each model.

Note Do not attach more than one Positive Supply Rail block to any connected line.

Dialog Box and Parameters

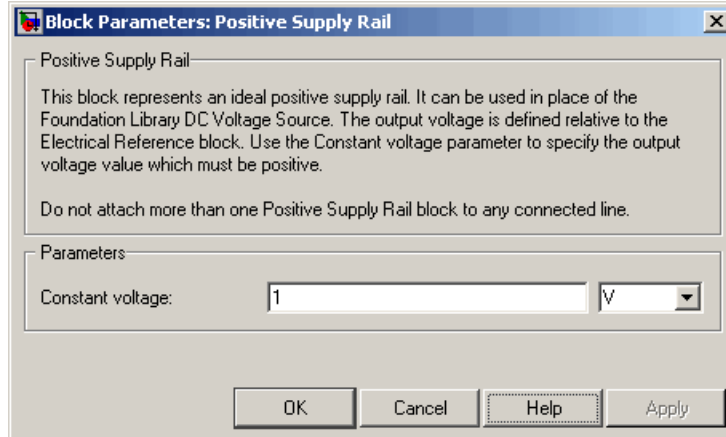

Positive Supply Rail

Constant voltage

The voltage at the output port relative to the Electrical Reference block ground port. The value must be greater than zero. The default value is 1 V.

Ports

The block has the following ports:

+

Positive electrical voltage.

See Also

Simscape DC Voltage Source, Negative Supply Rail

Purpose Model simple distance sensor

Library Sensors

Description The Proximity Sensor block represents a simple proximity sensor. The sensing distance Z is defined as the distance normal to the sensor surface at which the sensor detects an object for a given radial offset R , as shown in the following figure.

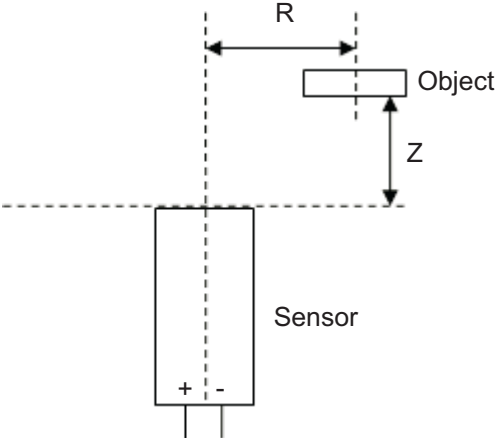
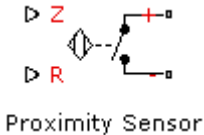

A typical sensing distance curve is shown in the following figure.

Proximity Sensor

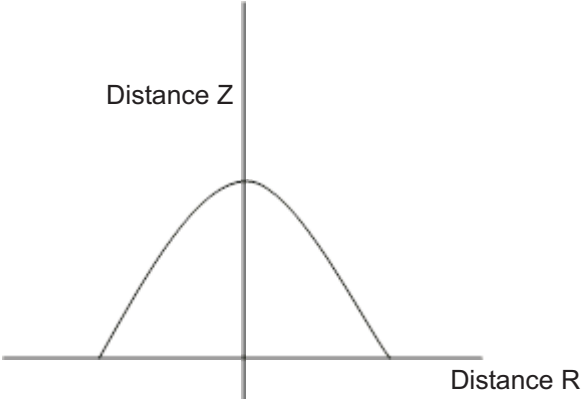

The output is modeled by an electrical switch which can either be Normally Open (N.O.) or Normally Closed (N.C.) when no object is detected.

Dialog Box and Parameters

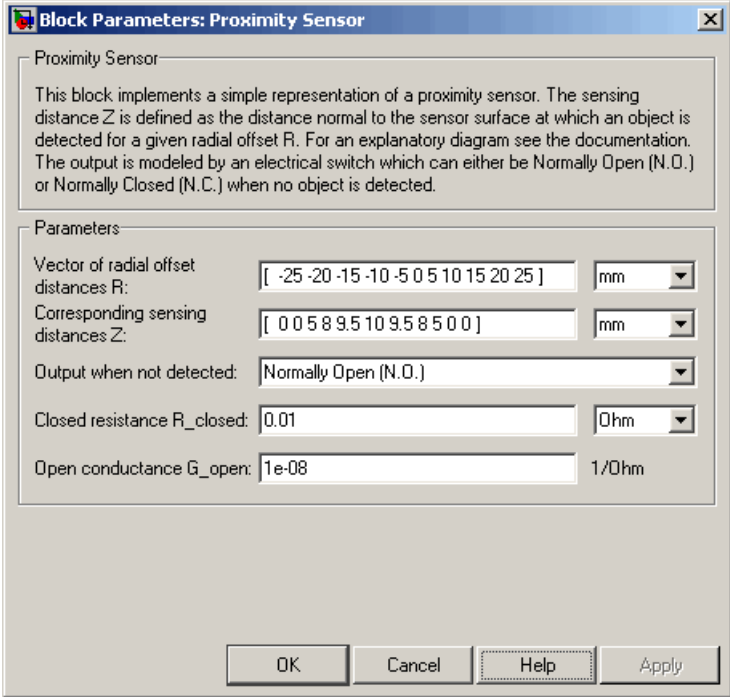

Vector of radial offset distances **R**

Vector of distances from the sensor to the object resolved into a plane tangential to the sensor head. The default value is [-25 -20 -15 -10 -5 0 5 10 15 20 25] mm.

Corresponding sensing distances **Z**

Vector of distances from the sensor to the object resolved with respect to a normal vector at the sensor head. The default value is [0 0 5 8 9.5 10 9.5 8 5 0 0] mm.

Output when not detected

Indicates whether the output is Normally Open (N.O.), meaning the output becomes closed only when the object is detected, or Normally Closed (N.C.), meaning the output becomes open

Proximity Sensor

only when the object is detected. The default value is Normally Open (N.O.).

Closed resistance R_{closed}

The resistance between the + and - ports when the output contacts are closed. The default value is 0.01 Ω .

Open conductance G_{open}

The conductance between the + and - ports when the output contacts are open. The default value is 1e-08 1/ Ω .

Ports

The block has the following ports:

- R
Radial distance to the sensor.
- Z
Perpendicular distance to the sensor.
- +
Positive electrical voltage.
- Negative electrical voltage.

Purpose Model generic linear sensor

Library Sensors

Description

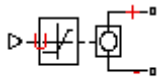

PS Sensor

The PS Sensor block represents a generic linear sensor. The block converts the physical signal input U into an electrical output Y across the + and - ports. The **Output type** parameter value determines which of the following electrical outputs the block produces:

- Output voltage
- Output current
- Output resistance

Y is related to U as $Y = \max(\min(A * U + B, Y_{\max}), Y_{\min})$ where Y_{\min} and Y_{\max} are minimum and maximum limits on the output, respectively.

Dialog Box and Parameters

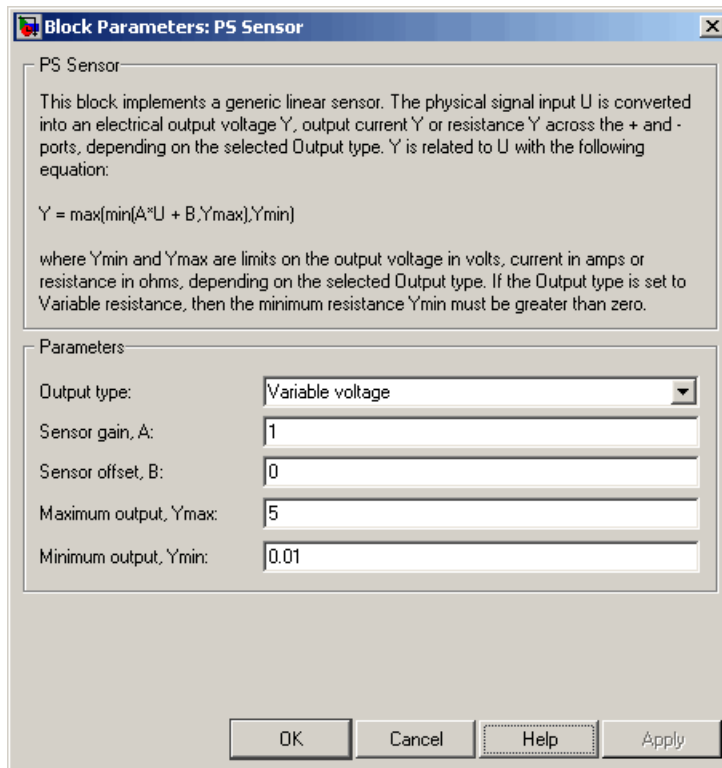

Output type

Indicates whether the sensor output is a Variable voltage of Y V, a Variable current of Y A, or Variable resistor with a value of $Y \Omega$. The default value is Variable voltage.

Sensor gain, A

The sensitivity of the output Y with respect to the input U , dY/dU . The default value is 1.

Sensor offset, B

The output when the input U is zero. The output does not exceed the limits Y_{\max} and Y_{\min} . The default value is 0.

Maximum output, Ymax

The upper limit on the sensor output. The following table shows the units of this parameter, which depend on the selected value of the **Output type** parameter.

Output type	Units
Variable voltage	V
Variable current	A
Variable resistor	Ω

The default value is 5.

Minimum output, Ymin

The lower limit on the sensor output. The following table shows the units of this parameter, which depend on the selected value of the **Output type** parameter.

Output type	Units
Variable voltage	V
Variable current	A
Variable resistor	Ω

The default value is 0.01.

If you select Variable resistance for the **Output type** parameter, the minimum resistance Y_{min} must be greater than zero.

Ports

The block has the following ports:

- U
Physical input signal.
- +
Positive electrical voltage.

PS Sensor

- Negative electrical voltage.

See Also

Simscape Controlled Voltage Source, Simscape Controlled Current Source, and Simscape Variable Resistor

Purpose Model periodic square pulse current source

Library SPICE-Compatible Sources

Description



Pulse Current Source

The Pulse Current Source block represents a current source whose output current value is a periodic square pulse as a function of time and is independent of the voltage across the terminals of the source. The following equations describe the current through the source as a function of time:

$$I_{out}(0) = I1$$

$$I_{out}(TD) = I1$$

$$I_{out}(TD + TR) = I2$$

$$I_{out}(TD + TR + PW) = I2$$

$$I_{out}(TD + TR + PW + TF) = I1$$

$$I_{out}(TD + PER) = I1$$

where:

- $I1$ is the **Initial value**, **I1** parameter value.
- $I2$ is the **Pulse value**, **I2** parameter value.
- TD is the **Pulse delay time**, **TD** parameter value.
- TR is the **Pulse rise time**, **TR** parameter value.
- TF is the **Pulse fall time**, **TF** parameter value.
- PW is the **Pulse width**, **PW** parameter value.

Pulse Current Source

- PER is the **Pulse period, PER** parameter value.

The block determines the values at intermediate time points by linear interpolation.

The specified values for PW and PER have the following effect on the block output:

- If both PW and PER are infinite, the block produces a step response at time TD .
- If PER is infinite and PW is finite, the block produces a single pulse of width PW and infinite period.
- If PW is infinite and PER is finite, the block produces a step response with pulses of width TR to a value $I1$ every PER seconds.
- If $PW > PER$, the block produces a step response with pulses of width TR to a value $I1$ every PER seconds.

The block uses a small conductance internally to prevent numerical simulation issues. The conductance connects the + and - ports of the device and has a conductance $GMIN$:

- By default, $GMIN$ matches the **Minimum conductance GMIN** parameter of the SPICE Environment Parameters block, whose default value is $1e-12$.
- To change $GMIN$, add a SPICE Environment Parameters block to your model and set the **Minimum conductance GMIN** parameter to the desired value.

Dialog Box and Parameters

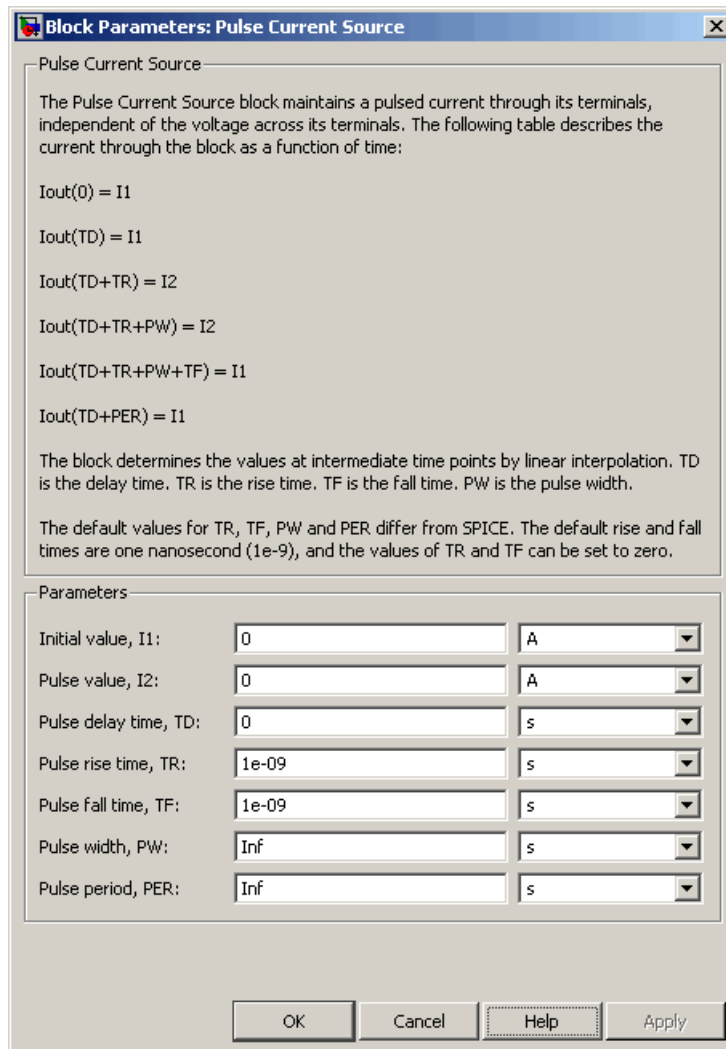

Initial value, I1

The value of the output current at time zero. The default value is 0 A.

Pulse Current Source

Pulse value, I2

The value of the output current when the output is high. The default value is 0 A.

Pulse delay time, TD

The time at which the pulse first starts. The default value is 0 s.

Pulse rise time, TR

The time it takes the output current to rise from the **Initial value, I1** value to the **Pulse value, I2** value. The default value is 1e-09 s. The value must be greater than or equal to 0.

Pulse fall time, TF

The time it takes the output current to fall from the **Pulse value, I2** value to the **Initial value, I1** value. The default value is 1e-09 s. The value must be greater than or equal to 0.

Pulse width, PW

The time width of the output pulse. The default value is Inf s. The value must be greater than 0.

Pulse period, PER

The period of the output pulse. The default value is Inf s. This value means that the block produces a single pulse with an infinite period. The value must be greater than 0.

Ports

The block has the following ports:

+

Positive electrical voltage.

-

Negative electrical voltage.

See Also

Pulse Voltage Source

Purpose Model periodic square pulse voltage source

Library SPICE-Compatible Sources

Description



Pulse Voltage Source

The Pulse Voltage Source block represents a voltage source whose output voltage value is a periodic square pulse as a function of time and is independent of the current through the source. The following equations describe the output voltage as a function of time:

$$V_{out}(0) = V1$$

$$V_{out}(TD) = V1$$

$$V_{out}(TD + TR) = V2$$

$$V_{out}(TD + TR + PW) = V2$$

$$V_{out}(TD + TR + PW + TF) = V1$$

$$V_{out}(TD + PER) = V1$$

where:

- $V1$ is the **Initial value**, **V1** parameter value.
- $V2$ is the **Pulse value**, **V2** parameter value.
- TD is the **Pulse delay time**, **TD** parameter value.
- TR is the **Pulse rise time**, **TR** parameter value.
- TF is the **Pulse fall time**, **TF** parameter value.
- PW is the **Pulse width**, **PW** parameter value.
- PER is the **Pulse period**, **PER** parameter value.

Pulse Voltage Source

The block determines the values at intermediate time points by linear interpolation.

The specified values for PW and PER have the following effect on the block output:

- If both PW and PER are infinite, the block produces a step response at time TD .
- If PER is infinite and PW is finite, the block produces a single pulse of width PW and infinite period.
- If PW is infinite and PER is finite, the block produces a step response with pulses of width TR to a value $V1$ every PER seconds.
- If $PW > PER$, the block produces a step response with pulses of width TR to a value $V1$ every PER seconds.

Dialog Box and Parameters

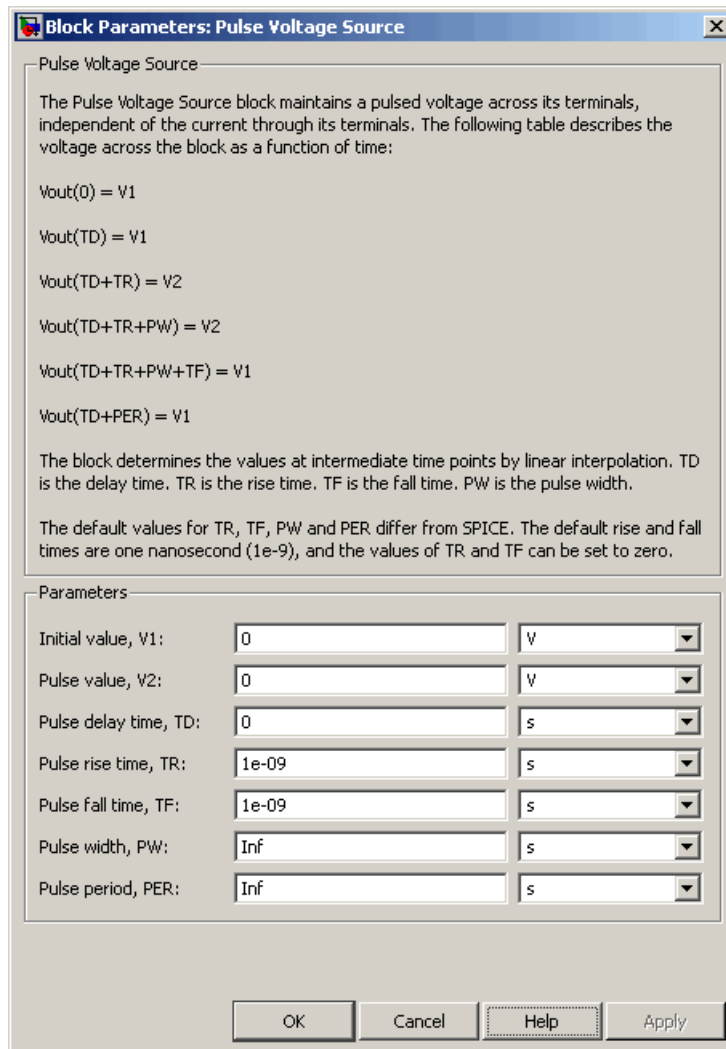

Initial value, V1

The value of the output voltage at time zero. The default value is 0 V.

Pulse Voltage Source

Pulse value, V2

The value of the output voltage when the output is high. The default value is 0 V.

Pulse delay time, TD

The time at which the pulse first starts. The default value is 0 s.

Pulse rise time, TR

The time it takes the output voltage to rise from the **Initial Value, I1** value to the **Pulse Value, V2** value. The default value is 1e-09 s. The value must be greater than or equal to 0.

Pulse fall time, TF

The time it takes the output voltage to fall from the **Pulse Value, V2** value to the **Initial Value, V1** value. The default value is 1e-09 s. The value must be greater than or equal to 0.

Pulse width, PW

The time width of the output pulse. The default value is Inf s.

Pulse period, PER

The period of the output pulse. The default value is Inf s. This value means that the block produces a single pulse with an infinite period.

Ports

The block has the following ports:

+

Positive electrical voltage.

-

Negative electrical voltage.

See Also

Pulse Current Source

Purpose Model polynomial voltage-controlled current source

Library SPICE-Compatible Sources

Description

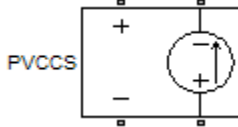

The PVCCS (Polynomial Voltage-Controlled Current Source) block represents a current source whose output current value is a polynomial function of the voltage across the input ports. The following equations describe the current through the source as a function of time:

- If you specify an n -element vector of polynomial coefficients for the **Polynomial coefficients** parameter:

$$I_{out} = p(0) + p(1) * V_{in} + \dots + p(n - 1) * V_{in}^{n-1} + p(n) * V_{in}^n$$

- If you specify a scalar coefficient for the **Polynomial coefficients** parameter:

$$I_{out} = p * V_{in}$$

where:

- V_{in} is the voltage across the input ports.
- p is the **Polynomial coefficients** parameter value.

The block uses a small conductance internally to prevent numerical simulation issues. The conductance connects the output ports of the device and has a conductance $GMIN$:

- By default, $GMIN$ matches the **Minimum conductance GMIN** parameter of the SPICE Environment Parameters block, whose default value is $1e-12$.
- To change $GMIN$, add a SPICE Environment Parameters block to your model and set the **Minimum conductance GMIN** parameter to the desired value.

Dialog Box and Parameters

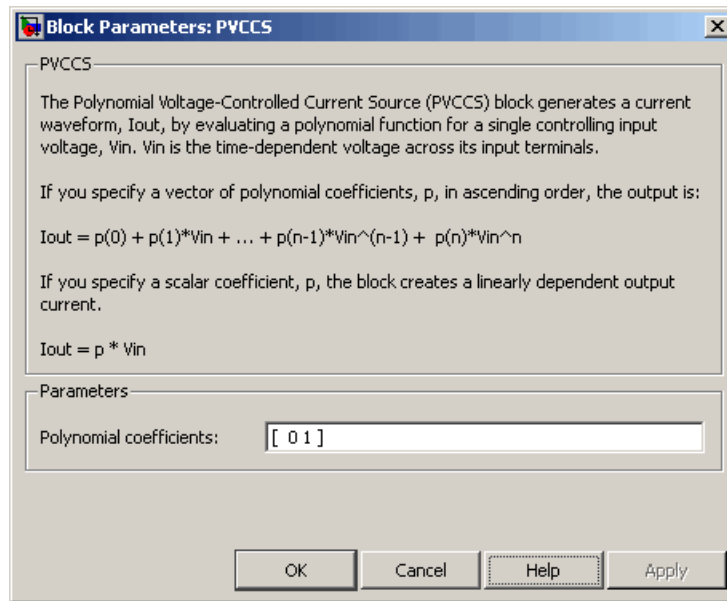

Polynomial coefficients

The polynomial coefficients that relate the input voltage to the output current, as described in the preceding section. The default value is [0 1].

Ports

The block has the following ports:

- + Positive electrical input voltage.
- Negative electrical input voltage.
- N+ Positive electrical output voltage.
- N- Negative electrical output voltage.

See Also PCCCS, PCCVS, PVCCS2, and PVCVS

Purpose

Model polynomial voltage-controlled current source with two controlling inputs

Library

SPICE-Compatible Sources

Description

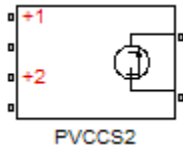

The PVCCS2 (Two-Input Polynomial Voltage-Controlled Current Source) block represents a current source whose output current value is a polynomial function of the voltages across the pairs of controlling input ports. The following equations describes the current through the source as a function of time:

$$I_{out} = p_1 + p_2 * V_{in1} + p_3 * V_{in2} + p_4 * V_{in1}^2 + p_5 V_{in1} * V_{in2} + p_6 * V_{in2}^2 + \dots$$

where:

- V_{in1} is the voltage across the first pair of input ports.
- V_{in2} is the voltage across the second pair of input ports.
- p is the **Polynomial coefficients** parameter value.

The block uses a small conductance internally to prevent numerical simulation issues. The conductance connects the output ports of the device and has a conductance $GMIN$:

- By default, $GMIN$ matches the **Minimum conductance GMIN** parameter of the SPICE Environment Parameters block, whose default value is $1e-12$.
- To change $GMIN$, add a SPICE Environment Parameters block to your model and set the **Minimum conductance GMIN** parameter to the desired value.

Dialog Box and Parameters

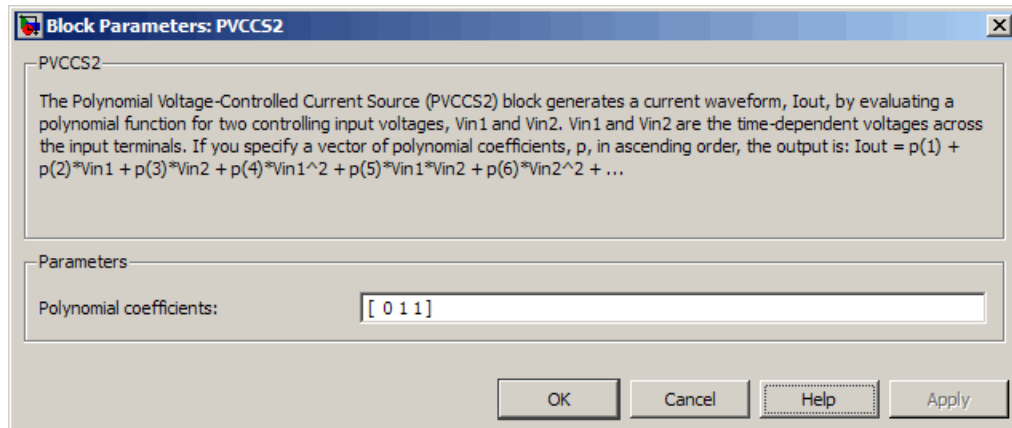

Polynomial coefficients

The polynomial coefficients that relate the input voltage to the output current, as described in the preceding section. The default value is [0 1 1].

Ports

The block has the following ports:

- +1 Positive electrical input voltage of first controlling source.
- 1 Negative electrical input voltage of first controlling source.
- +2 Positive electrical input voltage of second controlling source.
- 2 Negative electrical input voltage of second controlling source.
- N+ Positive electrical output voltage.
- N- Negative electrical output voltage.

PVCCS2

See Also

PCCCS2, PCCVS2, PVCCS, and PVCVS2

Purpose Model polynomial voltage-controlled voltage source

Library SPICE-Compatible Sources

Description

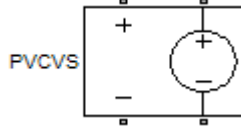

The PVCVS (Polynomial Voltage-Controlled Voltage Source) block represents a voltage source whose output voltage value is a polynomial function of the voltage across the input ports. The following equations describe the voltage across the source as a function of time:

- If you specify an n -element vector of polynomial coefficients for the **Polynomial coefficients** parameter:

$$V_{out} = p(0) + p(1) * V_{in} + \dots + p(n-1) * V_{in}^{n-1} + p(n) * V_{in}^n$$

- If you specify a scalar coefficient for the **Polynomial coefficients** parameter:

$$V_{out} = p * V_{in}$$

where:

- V_{in} is the voltage across the input ports.
- p is the **Polynomial coefficients** parameter value.

Dialog Box and Parameters

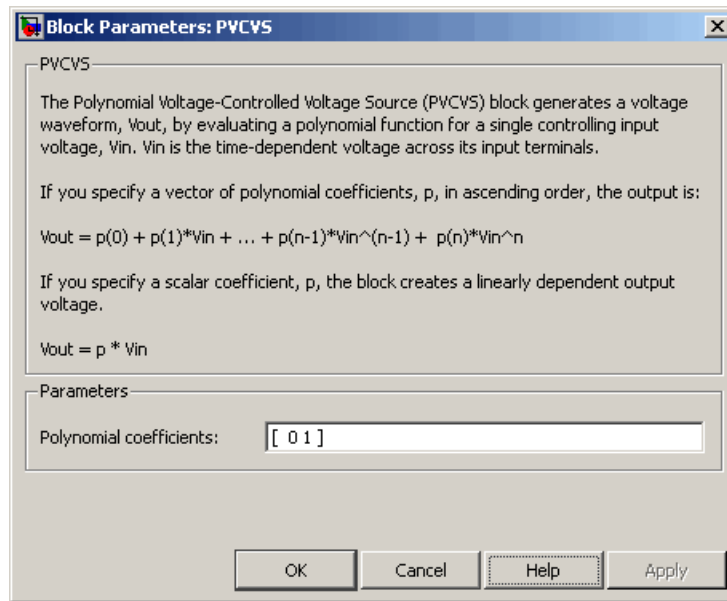

Polynomial coefficients

The polynomial coefficients that relate the input voltage to the output voltage, as described in the preceding section. The default value is [0 1].

Ports

The block has the following ports:

- + Positive electrical input voltage.
- Negative electrical input voltage.
- N+ Positive electrical output voltage.
- N- Negative electrical output voltage.

See Also PCCCS, PCCVS, PVCCS, and PVCVS2

PVCVS2

Purpose

Model polynomial voltage-controlled voltage source with two controlling inputs

Library

SPICE-Compatible Sources

Description

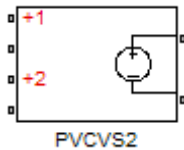

The PVCVS2 (Two-Input Polynomial Voltage-Controlled Voltage Source) block represents a voltage source whose output voltage value is a polynomial function of the voltages across the pairs of controlling input ports. The following equations describes the voltage across the source as a function of time:

$$V_{out} = p_1 + p_2 * V_{in1} + p_3 * V_{in2} + p_4 * V_{in1}^2 + p_5 V_{in1} * V_{in2} + p_6 * V_{in2}^2 + \dots$$

where:

- V_{in1} is the voltage across the first pair of input ports.
- V_{in2} is the voltage across the second pair of input ports.
- p is the **Polynomial coefficients** parameter value.

The block uses a small conductance internally to prevent numerical simulation issues. The conductance connects the output ports of the device and has a conductance *GMIN*:

- By default, *GMIN* matches the **Minimum conductance GMIN** parameter of the SPICE Environment Parameters block, whose default value is $1e-12$.
- To change *GMIN*, add a SPICE Environment Parameters block to your model and set the **Minimum conductance GMIN** parameter to the desired value.

Dialog Box and Parameters

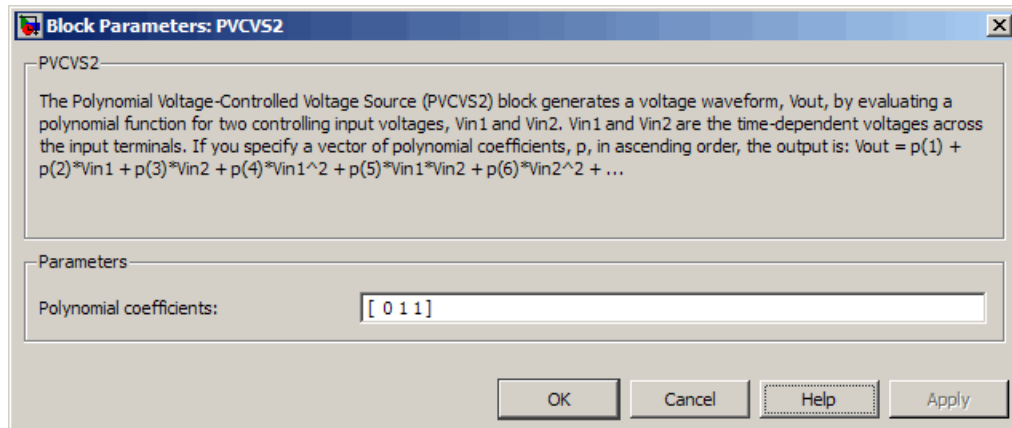

Polynomial coefficients

The polynomial coefficients that relate the input voltage to the output voltage, as described in the preceding section. The default value is [0 1 1].

Ports

The block has the following ports:

- +1 Positive electrical input voltage of first controlling source.
- 1 Negative electrical input voltage of first controlling source.
- +2 Positive electrical input voltage of second controlling source.
- 2 Negative electrical input voltage of second controlling source.
- N+ Positive electrical output voltage.
- N- Negative electrical output voltage.

PVCVS2

See Also

PCCCS2, PCCVS2, PVCCS2, and PVCVS

Purpose Model lookup table current source

Library SPICE-Compatible Sources

Description



PWL Current Source

The PWL Current Source block represents a current source that you specify in lookup table form using a vector of time values and a vector of the corresponding current values. You must specify at least four time-current value pairs. The block generates a time-dependent current based on these time-current values using the selected interpolation and extrapolation methods. You have a choice of three interpolation methods and two extrapolation methods. The output current is independent of the voltage across the terminals of the source.

The block uses a small conductance internally to prevent numerical simulation issues. The conductance connects the + and - ports of the device and has a conductance *GMIN*:

- By default, *GMIN* matches the **Minimum conductance GMIN** parameter of the SPICE Environment Parameters block, whose default value is $1e-12$.
- To change *GMIN*, add a SPICE Environment Parameters block to your model and set the **Minimum conductance GMIN** parameter to the desired value.

PWL Current Source

Dialog Box and Parameters

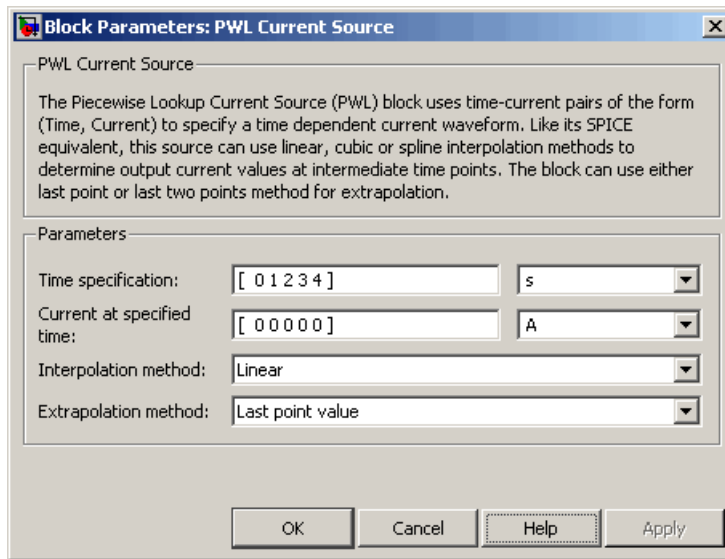

Time specification

The vector of time values as a tabulated 1-by-n array. The time values vector must be strictly monotonically increasing. The values can be non-uniformly spaced. The default value is [0 1 2 3 4] s.

Current at specified time

The vector of current values as a tabulated 1-by-n array. The current values vector must be the same size as the time values vector. The default value is [0 0 0 0 0] A.

Interpolation method

Select the method the block uses determine the output current values at intermediate time points that are not specified in the preceding vectors:

- **Linear** — Use a linear function. This is the default method.

- **Cubic** — Use the Piecewise Cubic Hermite Interpolation Polynomial (PCHIP). For more information, see [1] and the `pchip` MATLAB® function.
- **Spline** — Use the cubic spline interpolation algorithm described in [2].

Extrapolation method

Select the method the block uses determine the output current values at time points that are outside the time range specified in the preceding vectors:

- **Last point value** — Use the last specified current value at the appropriate end of the range. That is, use the last specified current value for all time values greater than the last specified time argument, and the first specified current value for all time values less than the first specified time argument. This is the default method.
- **Last 2 points** — Extrapolate using the linear method (regardless of the interpolation method specified), based on the last two current values at the appropriate end of the range. That is, use the first and second specified current values if the time value is below the specified range, and the two last specified current values if the time value is above the specified range.

Ports

The block has the following ports:

- +
Positive electrical voltage.
- Negative electrical voltage.

References

[1] D. Kahaner, Cleve Moler, and Stephen Nash *Numerical Methods and Software* Prentice Hall, 1988.

PWL Current Source

[2] W.H. Press, B.P. Flannery, S.A. Teukolsky, and W.T. Wetterling
Numerical Recipes in C: The Art of Scientific Computing Cambridge
University Press, 1992.

See Also

PWL Voltage Source

Purpose Model lookup table voltage source

Library SPICE-Compatible Sources

Description

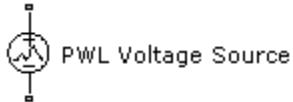

The PWL Voltage Source block represents a voltage source that you specify in lookup table form using a vector of time values and a vector of the corresponding voltage values. You must specify at least four time-current value pairs. The block generates a time-dependent voltage based on these time-voltage values using the selected interpolation and extrapolation methods. You have a choice of three interpolation methods and two extrapolation methods. The output voltage is independent of the current through the source.

Dialog Box and Parameters

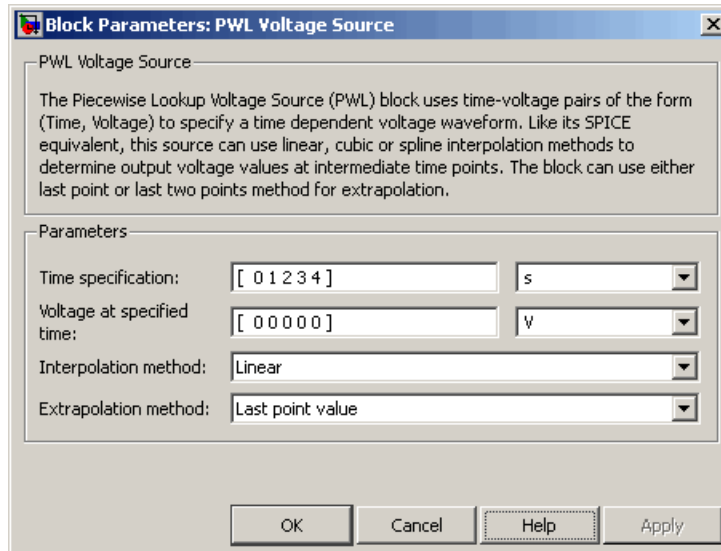

PWL Voltage Source

Time specification

The vector of time values as a tabulated 1-by-n array. The time values vector must be strictly monotonically increasing. The values can be non-uniformly spaced. The default value is [0 1 2 3 4] s.

Voltage at specified time

The vector of voltage values as a tabulated 1-by-n array. The voltage values vector must be the same size as the time values vector. The default value is [0 0 0 0 0] V.

Interpolation method

Select the method the block uses determine the output voltage values at intermediate time points that are not specified in the preceding vectors:

- **Linear** — Use a linear function. This is the default method.
- **Cubic** — Use the Piecewise Cubic Hermite Interpolation Polynomial (PCHIP). For more information, see [1] and the `pchip` MATLAB function.
- **Spline** — Use the cubic spline interpolation algorithm described in [2].

Extrapolation method

Select the method the block uses determine the output voltage values at time points that are outside the time range specified in the preceding vectors:

- **Last point value** — Use the last specified voltage value at the appropriate end of the range. That is, use the last specified voltage value for all time values greater than the last specified time argument, and the first specified voltage value for all time values less than the first specified time argument. This is the default method.
- **Last 2 points** — Extrapolate using the linear method (regardless of the interpolation method specified), based on the last two voltage values at the appropriate end of the range. That is, use the first and second specified voltage values if

the time value is below the specified range, and the two last specified voltage values if the time value is above the specified range.

Ports

The block has the following ports:

+

Positive electrical voltage.

-

Negative electrical voltage.

References

[1] D. Kahaner, Cleve Moler, and Stephen Nash *Numerical Methods and Software* Prentice Hall, 1988.

[2] W.H. Press, B.P. Flannery, S.A. Teukolsky, and W.T. Wetterling *Numerical Recipes in C: The Art of Scientific Computing* Cambridge University Press, 1992.

See Also

PWL Current Source

Relay

Purpose

Model switching and associated delay of relay

Library

Passive Devices

Description

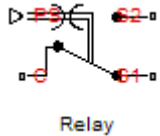

The Relay block models a relay controlled by an external physical signal. In the steady state, the relay behaves as follows:

- When the external physical signal at port PS is greater than the **Threshold** parameter, the relay is *energized* (meaning closed). The common port C connects to the normally open port S2.
- When the external physical signal at port PS is less than or equal to the **Threshold** parameter, the relay is *not energized* (meaning open). The common port C connects to the normally closed port S1.

During switching, the relay behaves as follows:

- When the relay closes, the C to S1 connection breaks open after delay **Time-to-break C-S1 connection**. The C to S2 connection closes after delay **Time-to-make C-S2 connection**.
- When the relay opens, the C to S2 connection breaks open after delay **Time-to-break C-S2 connection**. The C to S1 connection closes after delay **Time-to-make C-S1 connection**.

You can specify break delays that are longer than the close delays to implement a make-before-break behavior.

Basic Assumptions and Limitations

If the PS input changes during the switching process, the block behavior can be inaccurate. The switching delay occurs due to both mechanical inertia and the fact that modeling inertia as a delay requires approximation.

Dialog Box and Parameters

Block Parameters: Relay

Relay

The block represents a relay. If the external physical signal PS is greater than the threshold, then the common terminal C gets connected to terminal S2, otherwise terminal C is connected to terminal S1.

The Connected resistance R and Open-circuit conductance G must be greater than zero.

Parameters

Time-to-break C-S1 connection:	<input type="text" value="0"/>	s
Time-to-make C-S1 connection:	<input type="text" value="0"/>	s
Time-to-break C-S2 connection:	<input type="text" value="0"/>	s
Time-to-make C-S2 connection:	<input type="text" value="0"/>	s
Connected resistance R:	<input type="text" value="0.01"/>	Ohm
Open-circuit conductance G:	<input type="text" value="1e-08"/>	1/Ohm
Threshold:	<input type="text" value="0"/>	
Initial connection:	<input type="text" value="C to S1 closed, C to S2 open"/>	

OK Cancel Help Apply

Time-to-break C-S1 connection

Time it takes the connection between ports C and S1 to break apart when the relay is energized. The default value is 0 s.

Time-to-make C-S1 connection

Time it takes the connection between ports C and S1 to close when the relay is not energized. The default value is 0 s.

Time-to-break C-S2 connection

Time it takes the connection between ports C and S2 to break apart when the relay is not energized. The default value is 0 s.

Time-to-make C-S2 connection

Time it takes the connection between ports C and S2 to close when the relay is not energized. The default value is 0 s.

Connected resistance R

Resistance across closed relay contacts. The parameter value must be greater than zero. The default value is 0.01 Ω .

Open-circuit conductance G

Conductance across open relay contacts. The parameter value must be greater than zero. The default value is 1e-08 1/ Ω .

Threshold

If the external physical signal is greater than this value, the relay is energized. The default value is 0.

Initial connection

For the initial state of the relay, select one of the following options:

- C to S1 closed, C to S2 open — The common port C connects to the S1 contact. This is the default option.
- C to S1 open, C to S2 closed — The common port C connects to the S2 contact.

Ports

This block has the following ports:

PS

Physical signal that energizes and de-energizes the relay.

C

Common electrical port.

S1

Normally-closed electrical port.

S2

Normally-open electrical port.

See Also

Simscape Switch

Purpose Model SPICE-compatible resistor

Library Passive Devices

Description



Resistor

The Resistor block represents a SPICE-compatible resistor. You can specify the resistance in one of the following ways:

- As a resistance value
- As process information that the block uses to calculate a resistance value

The block models temperature dependence. There are two ways to specify the resistor temperature:

- When you select `Device` temperature for the **Model temperature dependence using** parameter, the resistor temperature is

$$T = T_C + T_O$$

where:

- T_C is the **Circuit temperature** parameter value from the SPICE Environment Parameters block. If this block doesn't exist in the circuit, T_C is the default value of this parameter.
- T_O is the **Offset local circuit temperature, TOFFSET** parameter value.
- When you select `Fixed` temperature for the **Model temperature dependence using** parameter, the resistor temperature is the **Fixed circuit temperature, TFIXED** parameter value.

The block adjusts the specified or calculated resistance value for temperature using the following equation:

$$R = R_0(1 + TC1(T - T_{nom}) + TC2(T - T_{nom})^2)$$

Where

Resistor

- R_0 is the specified or calculated resistance value.
- $TC1$ is the **First order temperature coefficient**, TC1 parameter value.
- $TC2$ is the **Second order temperature coefficient**, TC2 parameter value.
- T_{nom} is the **Parameter extraction temperature**, TMEAS parameter value.

Dialog Box and Parameters

Resistance Tab

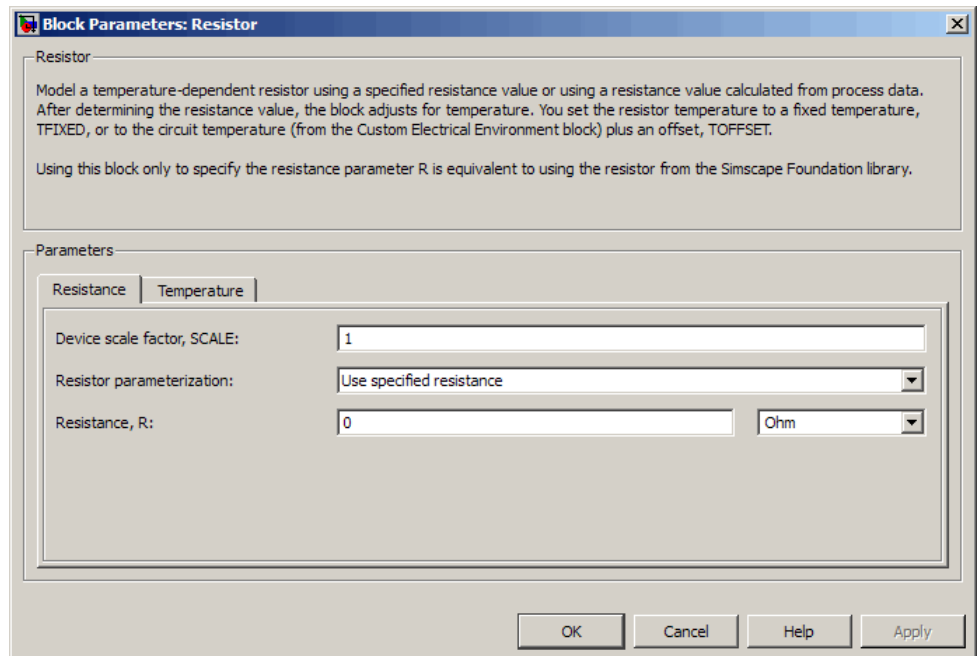

Device scale factor, SCALE

The number of parallel resistors that the block represents. This value multiplies the output current. The default value is 1.

Resistor parameterization

Select one of the following options for specifying the resistor value:

- **Use specified resistance** — Provide the resistance value directly. This option is the default.
- **Calculate from process information** — Provide process parameters that the block uses to calculate the resistance value.

When you select this option, the block calculates the resistance using the following equation:

$$R = RSH * \frac{(LENGTH - NARROW)}{(WIDTH - NARROW)}$$

where:

- *RSH* is the **Sheet resistance**, **RSH** parameter value.
- *LENGTH* is the **Resistor length**, **LENGTH** parameter value.
- *WIDTH* is the **Resistor width**, **WIDTH** parameter value.
- *NARROW* is the **Etch narrowing**, **NARROW** parameter value.

Resistance, R

Resistance value. This parameter is only visible when you select **Use specified resistance** for the **Resistor parameterization** parameter. The default value is 0 Ω.

Sheet resistance, RSH

Resistance per square of the resistor. This parameter is only visible when you select **Calculate from process information** for the **Resistor parameterization** parameter. The default value is 0 Ω.

Resistor length, LENGTH

Length dimension of the resistor. This parameter is only visible when you select **Calculate from process information** for the

Resistor

Resistor parameterization parameter. The default value is $1e-06$ m.

Resistor width, WIDTH

Width dimension of the resistor. This parameter is only visible when you select `Calculate` from process information for the **Resistor parameterization** parameter. The default value is $1e-06$ m.

Etch narrowing, NARROW

Amount by which the resistor length and width are reduced due to side etching. This parameter is only visible when you select `Calculate` from process information for the **Resistor parameterization** parameter. The default value is 0 m.

Temperature Tab

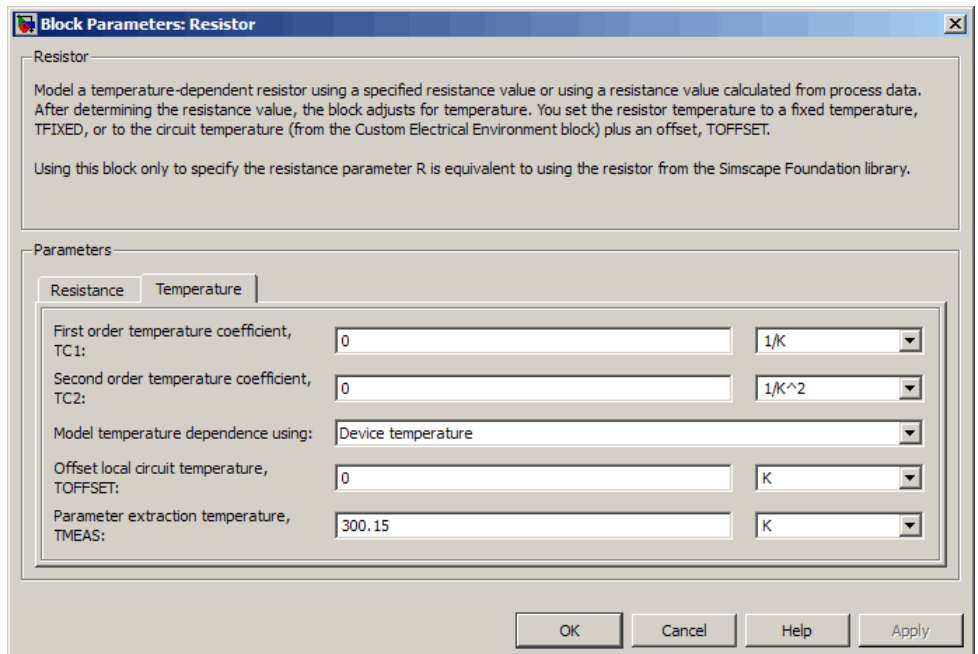

First order temperature coefficient, TC1

Coefficient for the linear term in the equation that the block uses to adjust the specified or calculated resistance value for temperature. The default value is 0 1/K.

Second order temperature coefficient, TC2

Coefficient for the quadratic term in the equation the block uses to adjust the specified or calculated resistance value for temperature. The default value is 0 1/K².

Model temperature dependence using

Select one of the following options for modeling the resistor temperature dependence:

- **Device temperature** — Use the device temperature, which is the **Circuit temperature** parameter value (from the SPICE Environment Parameters block, if one exists in the circuit, or the default value for this block otherwise) plus the **Offset local circuit temperature, TOFFSET** parameter value.
- **Fixed temperature** — Use a temperature that is independent of the circuit temperature to model temperature dependence.

Offset local circuit temperature, TOFFSET

The amount by which the resistor temperature differs from the circuit temperature. This parameter is only visible when you select **Device temperature** for the **Model temperature dependence using** parameter. The default value is 0 K.

Parameter extraction temperature, TMEAS

The temperature at which the resistor parameters were measured. The default value is 300.15 K. The value must be greater than 0.

Fixed circuit temperature, TFIXED

The temperature at which to simulate the resistor. This parameter is only visible when you select **Fixed temperature** for the **Model temperature dependence using** parameter. The default value is 300.15 K. The value must be greater than 0.

Ports

The block has the following ports:

Resistor

- + Positive electrical voltage.
- Negative electrical voltage.

See Also

Diode

Purpose Model an S-R Latch behaviorally

Library Logic

Description

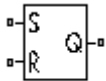

S-R Latch

The S-R Latch block is an abstracted behavioral model of a set-reset latch. It does not model the internal individual MOSFET devices. Therefore, the block runs quickly during simulation but retains the correct I/O behavior.

The block models gate inputs electrically as having infinite resistance and a finite or zero capacitance. If the gate voltage is greater than the threshold voltage V_{TH} , then the input taken is 1 (HIGH). Otherwise, the input is zero (LOW). The gate threshold voltage V_{TH} is halfway between the **Low level input voltage** (V_{IL}) and **High level input voltage** (V_{IH}) parameters.

The block models the gate output as a voltage source driving a series resistor and a capacitor that connects to ground. The output pin connects to the resistor-capacitor connection node. The voltage source is equal to either the **Low level output voltage** (V_{OL}) or the **High level output voltage** (V_{OH}) parameter, according to the logic levels of the gate inputs and the S-R latch truth table.

S	R	Q
0	0	0
0	1	0
1	0	1
1	1	1

The block sets the value of the gate output capacitor such that the resistor-capacitor time constant is equal to the propagation delay.

S-R Latch

Basic Assumptions and Limitations

The block does not model the internal individual MOSFET devices that make up the gate. This limitation has the following implications:

- The behavior of this block is abstracted. In particular, response to input noise and inputs that are around the logic threshold voltage can be inaccurate. Also, dynamic response is approximate.
- The linear drop in output voltage as a function of output current is an approximation to the MOSFET or bipolar output behavior.
- Modeling of the output as a controlled voltage source is representative of a totem-pole or push-pull output stage. To model a device with an open-collector:
 - 1 Connect the output pin to the base of an NPN Bipolar Transistor or PNP Bipolar Transistor block.
 - 2 Set the **Output resistance** parameter to a suitable value.

Dialog Box and Parameters

Inputs Tab

Block Parameters: S-R Latch

S-R Latch
This block implements a simplified model of a set-reset latch. Set the input low, input high, output low and output high voltages for the supply voltage used. Default values are typical for a supply voltage of 5 volts.

Parameters

Inputs | Outputs

Low level input voltage: 2 V

High level input voltage: 3 V

Average input capacitance: 5 pF

OK Cancel Help Apply

Low level input voltage

Voltage value less than which the block interprets the input voltage as LOW. The default value is 2 V.

High level input voltage

Voltage value greater than which the block interprets the input voltage as HIGH. The default value is 3 V.

Average input capacitance

Fixed capacitance that approximates the input capacitance for a MOSFET gate. You can usually find this capacitance value on a manufacturer datasheet. The default value is 5 pF. Setting this value to zero can result in faster simulation times.

Outputs Tab

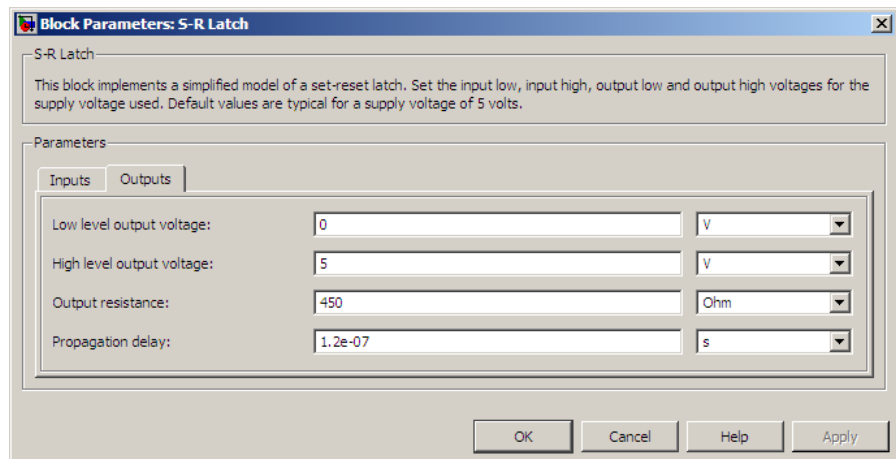

Low level output voltage

Voltage value V_{OL} at the output when the output logic level is LOW. The default value is 0 V.

High level output voltage

Voltage value V_{OH} at the output when the output logic level is HIGH. The default value is 5 V.

S-R Latch

Output resistance

This parameter is the ratio of output voltage drop to output current. Set this parameter to $(V_{OH} - V_{OH1}) / I_{OH1}$, where V_{OH1} is the reduced output high voltage when the output current is I_{OH1} . The default value is 450 Ω .

Propagation delay

Time it takes for the output to swing from LOW to HIGH or HIGH to LOW, after the input logic levels change. The default value is 1.2e-07 s.

Ports

This block has the following ports:

- S
Electrical input port corresponding to the set pin.
- R
Electrical input port corresponding to the reset pin.
- Q
Electrical output port corresponding to the output pin.

Purpose Model brushless motor with closed-loop torque control

Library Actuators & Drivers

Description

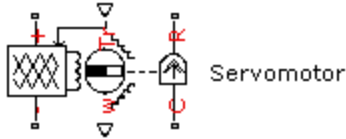

The Servomotor block represents a brushless motor with closed-loop torque control. This block abstracts the torque-speed behavior of the combined motor and motor driver in order to support system-level simulation where simulation speed is important.

The block allows for the range of torques and speeds that the torque-speed envelope defines. You specify this data in the block dialog box as a set of speed data points and corresponding maximum torque values. The following figure shows a typical torque-speed envelope for a servomotor.

Servomotor

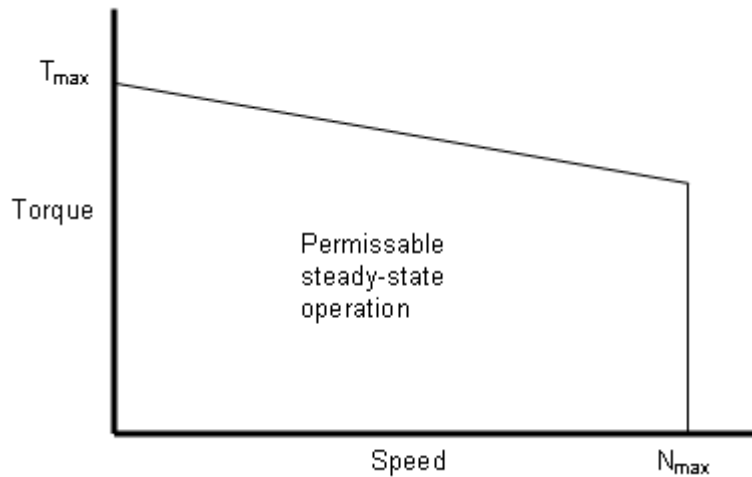

Specify the torque-speed envelope for the forward-direction motoring region (Quadrant 1) only. This region is typically the only one specified by manufacturers. The Servomotor block implements this torque-speed envelope regardless of motor direction or power flow direction, interpreting the x-axis as the absolute value of speed and the y-axis as the absolute value of torque.

The block models the electrical losses as the sum of three terms:

- 1 A supply series resistance.
- 2 A torque-independent electrical loss, P_0 .
- 3 A torque-dependent electrical loss $k\tau^2$, where τ is the torque and k is a constant.

The block produces a positive torque acting from the mechanical C to R ports.

Basic Assumptions and Limitations

This model is based on the following assumptions:

- The motor driver tracks a torque demand with a time constant T_c .
- Motor speed fluctuations due to mechanical load do not affect the motor torque tracking.

Dialog Box and Parameters

Electrical Torque Tab

Block Parameters: Servomotor

Servomotor

This block represents a servomotor and driver operating in torque-control mode. Based on the assumption that torque is proportional to current, this is equivalent to the driver controlling current. The motor's permissible range of torques and speeds is defined by the manufacturer torque-speed envelope, and the output torque is assumed to track the torque reference demand T_r with time constant T_c . If the motor manufacturer does not define an envelope, then set the vector of maximum torque values to $[T_{max} \ T_{max} \ 0 \ 0]$ and the vector of rotational speed values to $[0 \ (1-\epsilon)\omega_{max} \ (1+\epsilon)\omega_{max} \ 2\omega_{max}]$ where T_{max} is the rated maximum continuous torque, ω_{max} is the maximum speed and ϵ is a small positive number e.g. 0.01.

The controlled servomotor should be connected to a DC supply. Electrical losses are assumed to be the sum of a torque-independent term plus a term proportional to the square of the torque. In addition, a resistor in series with the supply can be included to model transmission losses between power supply and servomotor driver.

The block produces a positive torque acting from the mechanical C to R ports.

Parameters

Electrical Torque | Mechanical

Vector of rotational speeds:	[0 3.75e+03 7.5e+03 8e+03]	rpm
Vector of maximum torque values:	[0.09 0.08 0.07 0]	N*m
Torque control time constant, T_c :	0.02	s
Motor and driver overall efficiency (percent):	100	
Speed at which efficiency is measured:	3.75e+03	rpm
Torque at which efficiency is measured:	0.08	N*m
Torque-independent electrical losses:	0	W
Supply series resistance:	0	Ohm

OK Cancel Help Apply

Vector of rotational speeds

Rotational speeds for permissible steady-state operation. The default value is [0 3.75e+03 7.5e+03 8e+03] rpm. To avoid poor performance due to an infinite slope in the torque-speed

curve, specify a vector of rotational speeds that does not contain duplicate consecutive values.

Vector of maximum torque values

Maximum torque values for permissible steady-state operation.

These values correspond to the speeds in the **Vector of rotational speeds in RPM** parameter and define the torque-speed envelope for the motor. The default value is [0.09 0.08 0.07 0] Nm.

Torque Control time constant, Tc

Time constant with which the motor driver tracks a torque demand. The default value is 0.02 s.

Motor and driver overall efficiency (percent)

The block defines overall efficiency as

$$\eta = 100 \times \frac{\tau_0 \times \omega_0}{\tau_0 \times \omega_0 + P_0 + k\tau_0^2}$$

where:

- τ_0 represents the **Torque at which efficiency is measured**
- ω_0 represents the **Speed at which efficiency is measured**
- P_0 represents the **Torque-independent electrical losses**
- $k\tau_0^2$ represents the torque-dependent electrical losses.

At initialization, the block solves the efficiency equation for k .

The block neglects losses associated with the rotor damping.

Speed at which efficiency is measured

Speed that the block uses to calculate torque-dependent electrical losses. The default value is 3.75e+03 rpm.

Torque at which efficiency is measured

Torque that the block uses to calculate torque-dependent electrical losses. The default value is 0.08 Nm.

Torque-independent electrical losses

Fixed electrical loss associated with the driver when the motor current and torque are zero. The default value is zero.

Supply series resistance

The equivalent resistance used in series with the DC supply to model electrical losses that are proportional to the driver supply current. The block assumes that the DC supply current is approximately constant under constant load conditions. The default value is 0 Ω .

Mechanical Tab

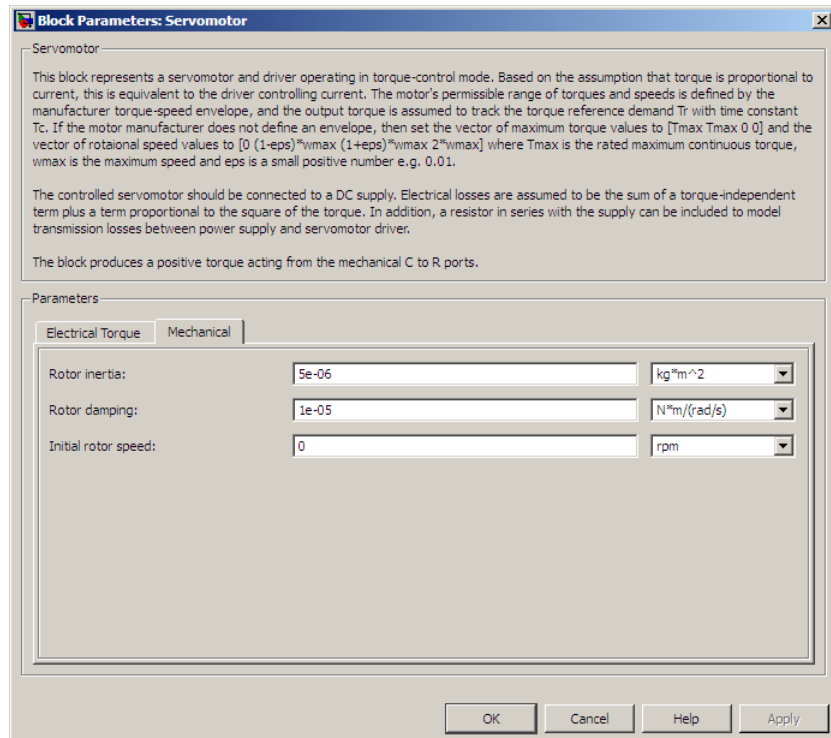

Servomotor

Rotor inertia

Rotor resistance to change in motor motion. The default value is $5e-06 \text{ kg}\cdot\text{m}^2$. The value can be zero.

Rotor damping

Rotor damping. The default value is $1e-05 \text{ N}\cdot\text{m}/(\text{rad}/\text{s})$. The value can be zero.

Initial rotor speed

Rotor speed at the start of the simulation. The default value is 0 rpm.

Ports

This block has the following ports:

- + Positive electrical DC supply.
- Negative electrical DC supply.
- Tr Reference torque demand.
- w Mechanical speed output.
- C Mechanical rotational conserving port.
- R Mechanical rotational conserving port.

See Also

Generic Rotary Actuator, DC Motor, Induction Motor, Shunt Motor, and Universal Motor.

Purpose Model single-frequency FM current source

Library SPICE-Compatible Sources

Description



SFFM Current Source

The SFFM Current Source block represents a single-frequency current source whose frequency-modulated output current value is independent of the voltage across its terminals. The following equation describes the current through the source as a function of time:

$$I_{out} = IO + IA * \sin((2\pi * FC * Time) + MI * \sin(2\pi * FS * Time))$$

where:

- *IO* is the **Current offset**, **IO** parameter value.
- *IA* is the **Current amplitude**, **IA** parameter value.
- *FC* is the **Carrier frequency**, **FC** parameter value.
- *MI* is the **Modulation index**, **MI** parameter value.
- *FS* is the **Signal frequency**, **FS** parameter value.

The block uses a small conductance internally to prevent numerical simulation issues. The conductance connects the + and - ports of the device and has a conductance *GMIN*:

- By default, *GMIN* matches the **Minimum conductance GMIN** parameter of the SPICE Environment Parameters block, whose default value is 1e-12.
- To change *GMIN*, add a SPICE Environment Parameters block to your model and set the **Minimum conductance GMIN** parameter to the desired value.

SFFM Current Source

Dialog Box and Parameters

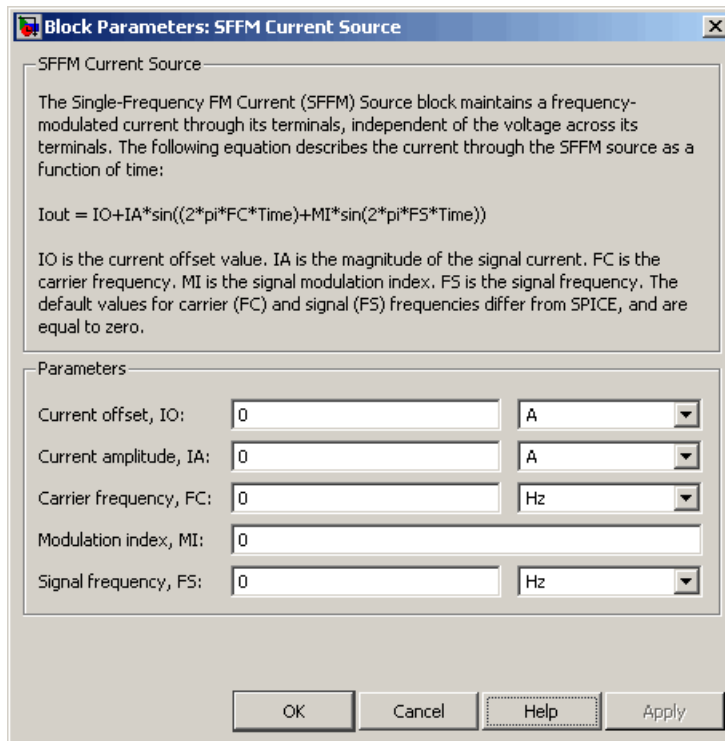

Current offset, I_O

The magnitude of the time-independent part of the output current. The default value is 0 A.

Current amplitude, I_A

The magnitude of the sinusoidal part of the output current. The default value is 0 A.

Carrier frequency, F_C

Frequency of the carrier wave. The default value is 0 Hz. The value must be greater than or equal to 0.

Modulation index, MI

The amount by which the modulated signal varies around its unmodulated level. The default value is 0. The value must be greater than or equal to 0.

Signal frequency, FS

Frequency of the modulated signal. The default value is 0 Hz. The value must be greater than or equal to 0.

Ports

The block has the following ports:

- +
Positive electrical voltage.
- Negative electrical voltage.

See Also

SFFM Voltage Source

SFFM Voltage Source

Purpose Model single-frequency FM voltage source

Library SPICE-Compatible Sources

Description

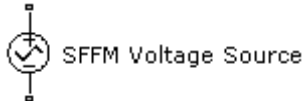

The SFFM Voltage Source block represents a single-frequency voltage source whose frequency-modulated output voltage value is independent of the current through the source. The following equation describes the output voltage as a function of time:

$$V_{out} = VO + VA * \sin((2\pi * FC * Time) + MI * \sin(2\pi * FS * Time))$$

where:

- VO is the **Voltage offset**, **VO** parameter value.
- VA is the **Voltage amplitude**, **VA** parameter value.
- FC is the **Carrier frequency**, **FC** parameter value.
- MI is the **Modulation index**, **MI** parameter value.
- FS is the **Signal frequency**, **FS** parameter value.

Dialog Box and Parameters

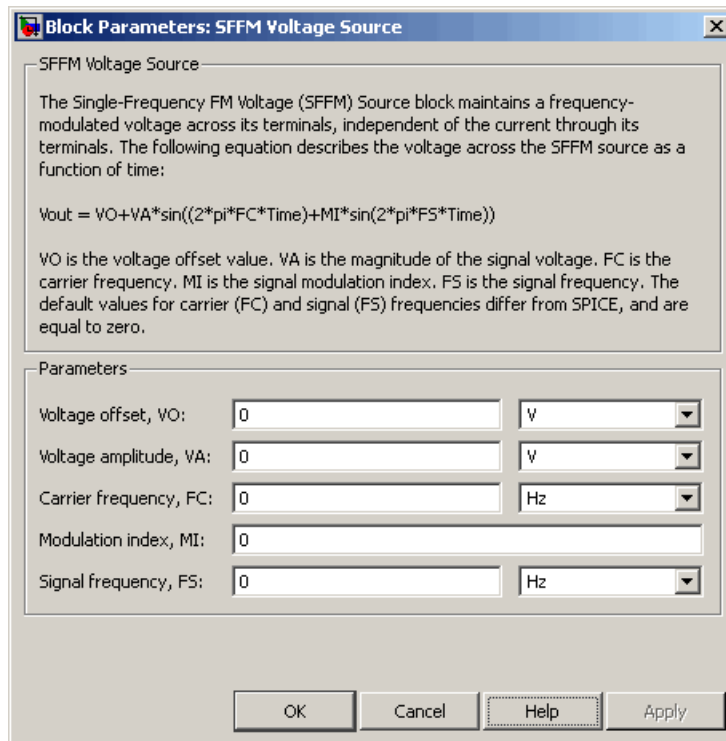

Voltage offset, V_O

The magnitude of the time-independent part of the output voltage. The default value is 0 V.

Voltage amplitude, V_A

The magnitude of the sinusoidal part of the output voltage. The default value is 0 V.

Carrier frequency, FC

Frequency of the carrier wave. The default value is 0 Hz. The value must be greater than or equal to 0.

SFFM Voltage Source

Modulation index, MI

The amount by which the modulated signal varies around its unmodulated level. The default value is 0. The value must be greater than or equal to 0.

Signal frequency, FS

Frequency of the modulated signal. The default value is 0 Hz. The value must be greater than or equal to 0.

Ports

The block has the following ports:

+

Positive electrical voltage.

-

Negative electrical voltage.

See Also

SFFM Current Source

Purpose Model electrical and torque characteristics of shunt motor

Library Actuators & Drivers

Description

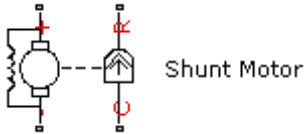

The Shunt Motor block represents the electrical and torque characteristics of a shunt motor using the following equivalent circuit model.

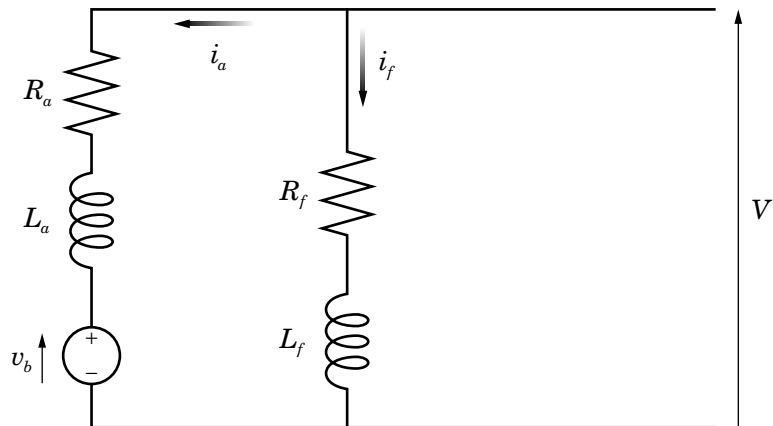

When you set the **Model parameterization** parameter to **By equivalent circuit parameters**, you specify the equivalent circuit parameters for this model:

- R_a — Armature resistance
- L_a — Armature inductance
- R_f — Field winding resistance

Shunt Motor

- L_f — **Field winding inductance**

The Shunt Motor block computes the motor torque as follows:

- 1 The magnetic field in the motor induces the following back emf v_b in the armature:

$$v_b = L_{af} i_f \omega$$

where L_{af} is a constant of proportionality and ω is the angular velocity.

- 2 The mechanical power is equal to the power reacted by the back emf:

$$P = v_b i_a = L_{af} i_f i_a \omega$$

- 3 The motor torque is:

$$T = P / \omega = L_{af} i_f i_a$$

The torque-speed characteristic for the Shunt Motor block model is related to the parameters in the preceding figure. When you set the **Model parameterization** parameter to **By rated power, rated speed & no-load speed**, the block solves for the equivalent circuit parameters as follows:

- 1 For the steady-state torque-speed relationship, L has no effect.

- 2 Sum the voltages around the loop:

$$V = i_a R_a + L_{af} i_f \omega$$

$$V = i_f R_f$$

- 3 Solve the preceding equations for i_a and i_f :

$$i_f = \frac{V}{R_f}$$
$$i_a = \frac{V}{R_a} \left(1 - \frac{L_{af}\omega}{R_f} \right)$$

4 Substitute these values of i_a and i_f into the equation for torque:

$$T = \frac{L_{af}}{R_a R_f} \left(1 - \frac{L_{af}\omega}{R_f} \right) V^2$$

The block uses the rated speed and power to calculate the rated torque. The block uses the rated torque and no-load speed values to get one equation that relates R_a and L_{af}/R_f . It uses the no-load speed at zero torque to get a second equation that relates these two quantities. Then, it solves for R_a and L_{af}/R_f .

The block models motor inertia J and damping B for all values of the **Model parameterization** parameter. The output torque is:

$$T_{load} = \frac{L_{af}}{R_a R_f} \left(1 - \frac{L_{af}\omega}{R_f} \right) V^2 - J\dot{\omega} - B\omega$$

The block produces a positive torque acting from the mechanical C to R ports.

Shunt Motor

Dialog Box and Parameters

Electrical Torque Tab

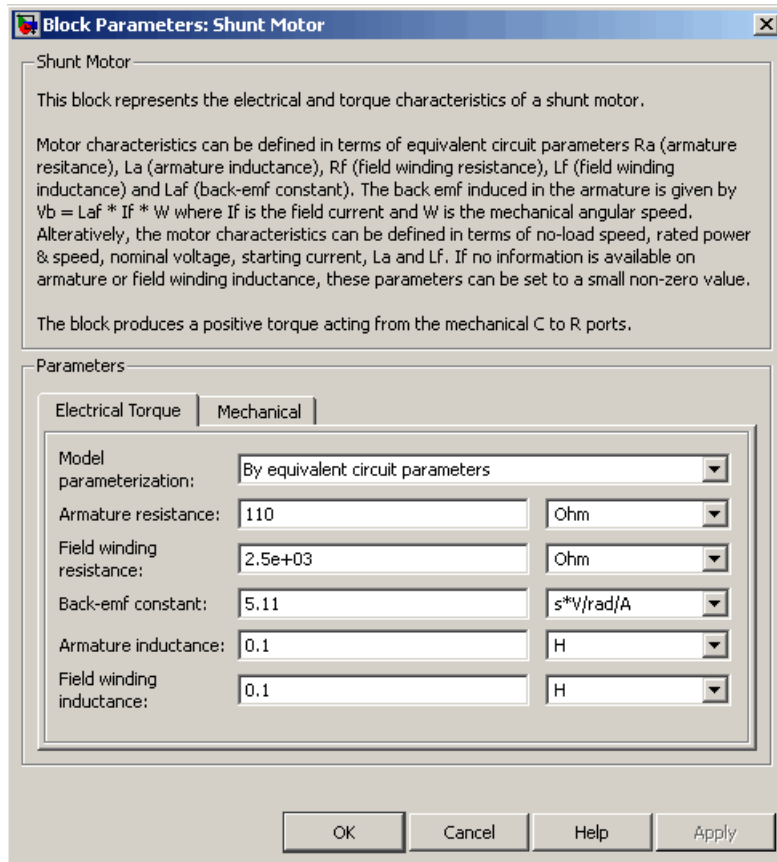

Model parameterization

Select one of the following methods for block parameterization:

- By equivalent circuit parameters — Provide electrical parameters for an equivalent circuit model of the motor. This is the default method.

- By rated power, rated speed & no-load speed — Provide power and speed parameters that the block converts to an equivalent circuit model of the motor.

Armature resistance

Resistance of the armature. This parameter is only visible when you select **By equivalent circuit parameters** for the **Model parameterization** parameter. The default value is 110 Ω .

Field winding resistance

Resistance of the field winding. This parameter is only visible when you select **By equivalent circuit parameters** for the **Model parameterization** parameter. The default value is 2.5e+03 Ω .

Back-emf constant

The ratio of the voltage generated by the motor to the motor speed. The default value is 5.11 s*V/rad/A.

Armature inductance

Inductance of the armature. If you do not have information about this inductance, set the value of this parameter to a small, nonzero number. The default value is 0.1 H. The value can be zero.

Field winding inductance

Inductance of the field winding. If you do not have information about this inductance, set the value of this parameter to a small, nonzero number. The default value is 0.1 H. The value can be zero.

No-load speed

Speed of the motor when no load is applied. This parameter is only visible when you select **By rated power, rated speed & no-load speed** for the **Model parameterization** parameter. The default value is 4.6e+03 rpm.

Rated speed (at rated load)

Motor speed at the rated load. This parameter is only visible when you select **By rated power, rated speed & no-load**

Shunt Motor

speed for the **Model parameterization** parameter. The default value is $4e+03$ rpm.

Rated load (mechanical power)

The mechanical load for which the motor is rated to operate. This parameter is only visible when you select **By rated power, rated speed & no-load speed** for the **Model parameterization** parameter. The default value is 50 W.

Rated DC supply voltage

The voltage at which the motor is rated to operate. This parameter is only visible when you select **By rated power, rated speed & no-load speed** for the **Model parameterization** parameter. The default value is 220 V.

Starting current at rated DC supply voltage

The initial current when starting the motor with the rated DC supply voltage. This parameter is only visible when you select **By rated power, rated speed & no-load speed** for the **Model parameterization** parameter. The default value is 2.09 A.

Mechanical Tab

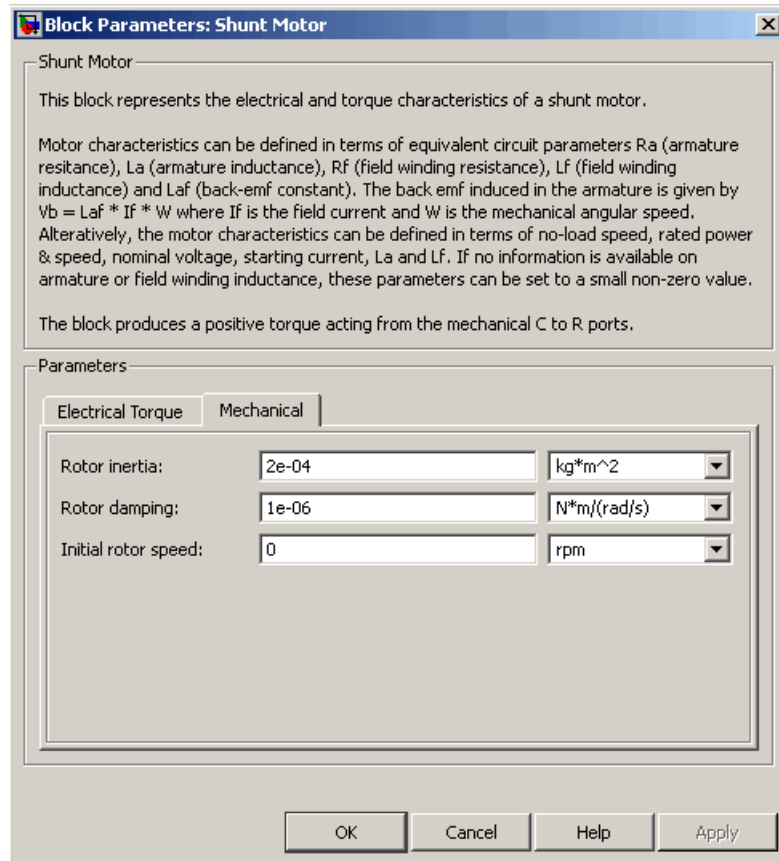

Rotor inertia

Rotor inertia. The default value is $2e-04 \text{ kg}\cdot\text{m}^2$. The value can be zero.

Rotor damping

Rotor damping. The default value is $1e-06 \text{ N}\cdot\text{m}/(\text{rad}/\text{s})$. The value can be zero.

Shunt Motor

Initial rotor speed

Speed of the rotor at the start of the simulation. The default value is 0 rpm.

Ports

The block has the following ports:

+

Positive electrical input.

-

Negative electrical input.

C

Mechanical rotational conserving port.

R

Mechanical rotational conserving port.

References

[1] Bolton, W. *Mechatronics: Electronic Control Systems in Mechanical and Electrical Engineering*, 3rd edition Pearson Education, 2004.

See Also

DC Motor, Induction Motor, Servomotor, and Universal Motor.

Purpose Model damped sinusoidal current source

Library SPICE-Compatible Sources

Description



Sinusoidal Current Source

The Sinusoidal Current Source block represents a damped sinusoidal current source whose output current is independent of the voltage across the terminals of the source. The following equations describe the current through the source as a function of time:

$$I_{out}(Time < TD) = IO$$

$$I_{out}(Time \geq TD) = IO + IA * e^{-(Time-TD)*DF} * \sin(2\pi * FREQ * (Time - TD))$$

where:

- IO is the **Current offset**, **IO** parameter value.
- IA is the **Sinusoidal amplitude**, **IA** parameter value.
- $FREQ$ is the **Sinusoidal frequency**, **FREQ** parameter value.
- TD is the **Time delay**, **TD** parameter value.
- DF is the **Damping factor**, **DF** parameter value.

The block uses a small conductance internally to prevent numerical simulation issues. The conductance connects the + and - ports of the device and has a conductance $GMIN$:

- By default, $GMIN$ matches the **Minimum conductance GMIN** parameter of the SPICE Environment Parameters block, whose default value is 1e-12.

Sinusoidal Current Source

- To change *GMIN*, add a SPICE Environment Parameters block to your model and set the **Minimum conductance GMIN** parameter to the desired value.

Dialog Box and Parameters

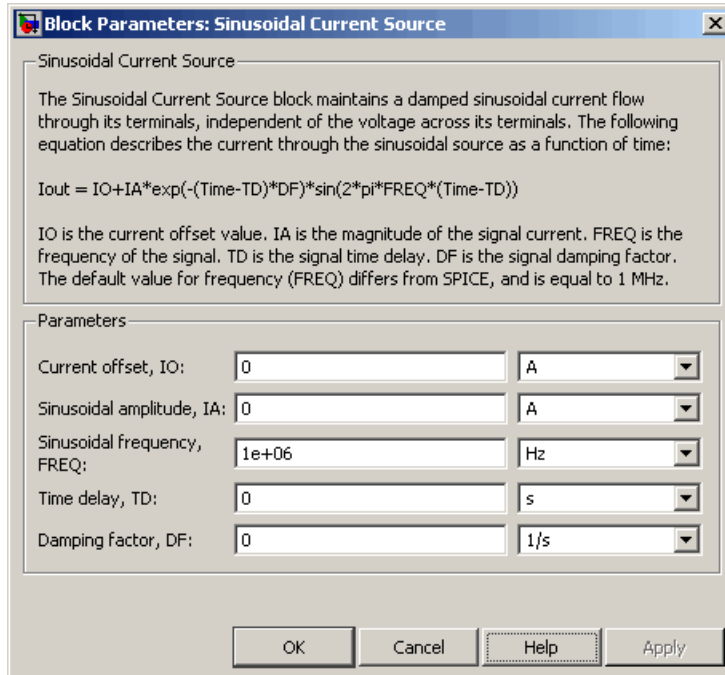

Current offset, I_0

The magnitude of the time-independent part of the output current. The default value is 0 A.

Sinusoidal amplitude, I_A

The magnitude of the sinusoidal part of the output current. The default value is 0 A.

Sinusoidal frequency, $FREQ$

The frequency of the output sine wave. The default value is 1e+06 Hz. The value can be less than 0.

Time delay, TD

The time at which the sine wave first starts. The default value is 0 s. The value can be less than 0.

Damping factor, DF

The amount by which to amplify or reduce the exponential damping term that multiplies the sine wave to produce the output current. The default value is 0 1/s. The value must be greater than or equal to 0.

Ports

The block has the following ports:

+

Positive electrical voltage.

-

Negative electrical voltage.

See Also

Sinusoidal Voltage Source

Sinusoidal Voltage Source

Purpose Model damped sinusoidal voltage source

Library SPICE-Compatible Sources

Description

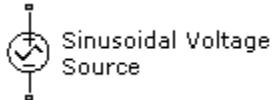

The Sinusoidal Voltage Source block represents a damped sinusoidal voltage source whose output voltage is independent of the current through the source. The following equations describe the output as a function of time:

$$V_{out}(Time < TD) = VO$$

$$V_{out}(Time \geq TD) = VO + VA * e^{-(Time-TD)*DF} * \sin(2\pi * FREQ * (Time - TD))$$

where:

- VO is the **Voltage offset**, **VO** parameter value.
- VA is the **Sinusoidal amplitude**, **VA** parameter value.
- $FREQ$ is the **Sinusoidal frequency**, **FREQ** parameter value.
- TD is the **Time delay**, **TD** parameter value.
- DF is the **Damping factor**, **DF** parameter value.

Dialog Box and Parameters

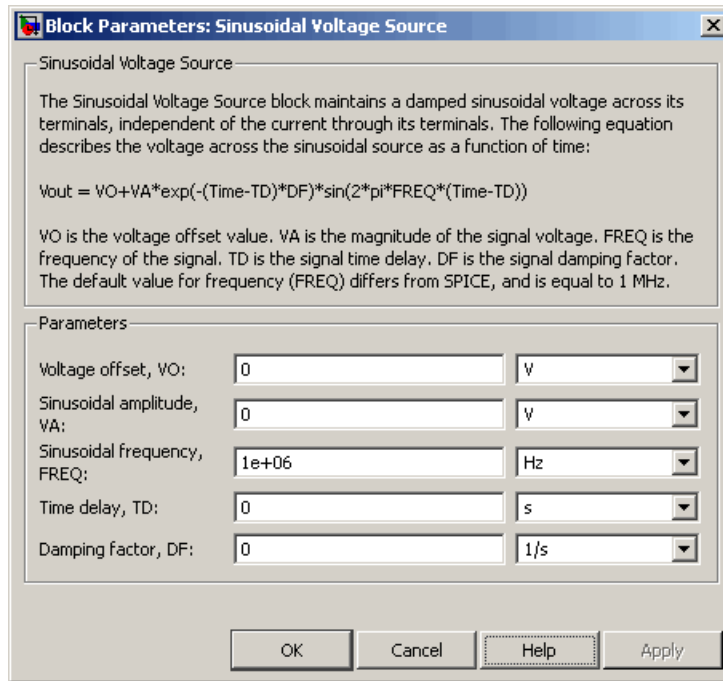

Voltage offset, V_0

The magnitude of the time-independent part of the output voltage. The default value is 0 V.

Sinusoidal amplitude, V_A

The magnitude of the sinusoidal part of the output voltage. The default value is 0 V.

Sinusoidal frequency, $FREQ$

The frequency of the output sine wave. The default value is 1e+06 Hz. The value can be less than 0.

Time delay, T_D

The time at which the sine wave first starts. The default value is 0 s. The value can be less than 0.

Sinusoidal Voltage Source

Damping factor, DF

The amount by which to amplify or reduce the exponential damping term that multiplies the sine wave to produce the output voltage. The default value is 0 1/s. The value must be greater than or equal to 0.

Ports

The block has the following ports:

+

Positive electrical voltage.

-

Negative electrical voltage.

See Also

Sinusoidal Current Source

Purpose

Model single solar cell

Library

Sources

Description

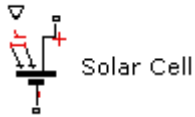

The Solar Cell block represents a solar cell current source.

The Solar Cell block model includes the following components:

- “Solar-Induced Current” on page 2-523
- “Temperature Dependence” on page 2-525

Solar-Induced Current

The block represents a single solar cell as a resistance R_s that is connected in series with a parallel combination of the following elements:

- Current source
- Two exponential diodes
- Parallel resistor R_p

The output current I is:

$$I = I_{ph} - I_s * \left(e^{(V+I*R_s)/(N_1*V_t)} - 1 \right) - I_{s2} * \left(e^{(V+I*R_s)/(N_2*V_t)} - 1 \right) - (V + I * R_s) / R_p$$

where:

- I_{ph} is the solar-induced current:

$$I_{ph} = I_{ph0} \times \frac{I_r}{I_{r0}}$$

where:

- I_r is the irradiance (light intensity) in W/m^2 falling on the cell.
- I_{ph0} is the measured solar-generated current for the irradiance I_{r0} .

Solar Cell

- I_s is the saturation current of the first diode.
- I_{s2} is the saturation current of the second diode.
- V_t is the thermal voltage, kT/q , where:
 - k is the Boltzmann constant.
 - T is the **device operating temperature** parameter value.
 - q is the elementary charge on an electron.
- N is the quality factor (diode emission coefficient) of the first diode.
- N_2 is the quality factor (diode emission coefficient) of the second diode.
- V is the voltage across the solar cell electrical ports.

The quality factor varies for amorphous cells, and is typically 2 for polycrystalline cells.

The block lets you choose between two models:

- An 8-parameter model where the preceding equation describes the output current
- A 5-parameter model that applies the following simplifying assumptions to the preceding equation:
 - The saturation current of the second diode is zero.
 - The impedance of the parallel resistor is infinite.

If you choose the 5-parameter model, you can parameterize this block in terms of the preceding equivalent circuit model parameters or in terms of the short-circuit current and open-circuit voltage the block uses to derive these parameters.

All models adjust the block resistance and current parameters as a function of temperature.

Temperature Dependence

Several solar cell parameters depend on temperature. There are two ways to specify the solar cell temperature:

- When you select `Device` temperature for the **Model temperature dependence using** parameter, the solar cell temperature is

$$T = T_C + T_O$$

where:

- T_C is the **Circuit temperature** parameter value from the SPICE Environment Parameters block. If this block doesn't exist in the circuit, T_C is the default value of this parameter.
- T_O is the **Offset local circuit temperature, TOFFSET** parameter value.
- When you select `Fixed` temperature for the **Model temperature dependence using** parameter, the solar cell temperature is the **Fixed circuit temperature, TFIXED** parameter value.

The block provides the following relationship between the solar-induced current I_{ph} and the solar cell temperature T :

$$I_{ph}(t) = I_{ph} * (1 + TIPH1 * (T - T_{meas}))$$

where:

- $TIPH1$ is the **First order temperature coefficient for Iph, TIPH1** parameter value.
- T_{meas} is the **Parameter extraction temperature, TMEAS** parameter value.

The block provides the following relationship between the saturation current of the first diode I_s and the solar cell temperature T :

Solar Cell

$$I_{s1}(T) = I_{s1} * \left(\frac{T}{T_{meas}} \right)^{(TXIS1/N)} * e^{\left(EG * \left(\frac{T}{T_{meas}} - 1 \right) \right) / (N * V_t)}$$

where $TXIS1$ is the **Temperature exponent for Is**, $TXIS1$ parameter value.

The block provides the following relationship between the saturation current of the second diode I_{s2} and the solar cell temperature T :

$$I_{s2}(T) = I_{s2} * \left(\frac{T}{T_{meas}} \right)^{(TXIS2/N_2)} * e^{\left(EG * \left(\frac{T}{T_{meas}} - 1 \right) \right) / (N_2 * V_t)}$$

where $TXIS2$ is the **Temperature exponent for Is2**, $TXIS2$ parameter value.

The block provides the following relationship between the series resistance R_s and the solar cell temperature T :

$$R_s(T) = R_s * \left(\frac{T}{T_{meas}} \right)^{TRS1}$$

where $TRS1$ is the **Temperature exponent for Rs**, $TRS1$ parameter value.

The block provides the following relationship between the parallel resistance R_p and the solar cell temperature T :

$$R_p(T) = R_p * \left(\frac{T}{T_{meas}} \right)^{TRP1}$$

where $TRP1$ is the **Temperature exponent for Rp**, $TRP1$ parameter value.

Dialog Box and Parameters

Main Tab

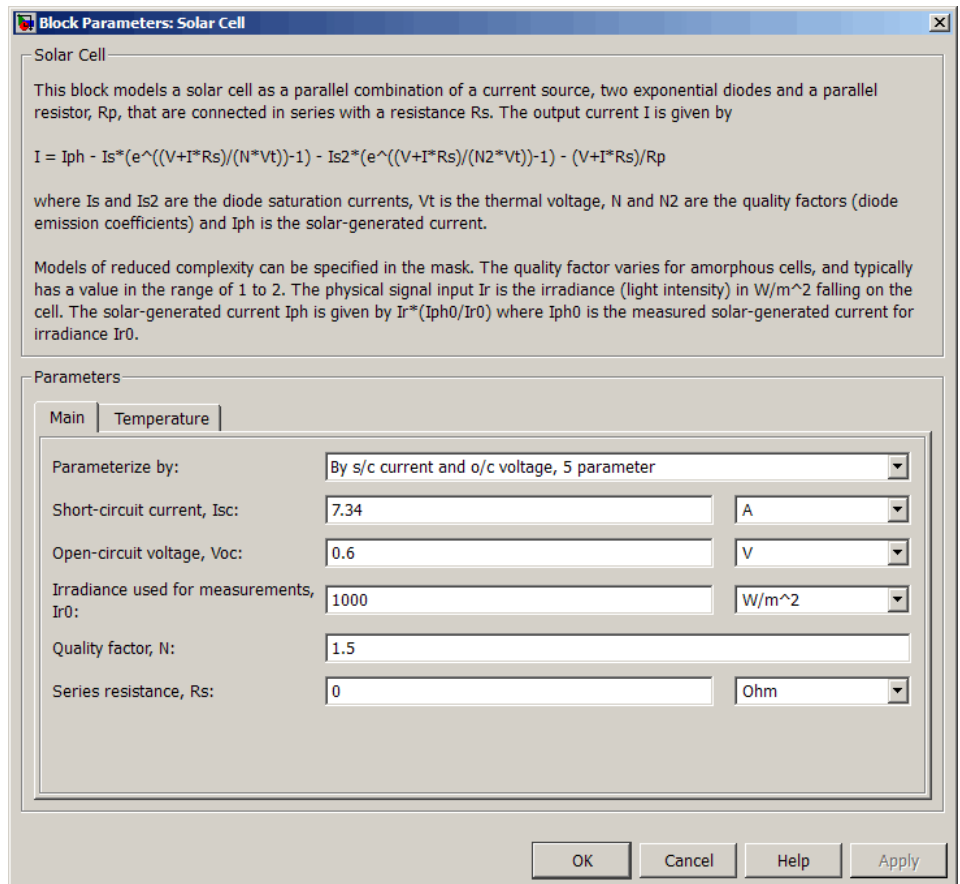

Parameterize by

Select one of the following methods for block parameterization:

- By s/c current and o/c voltage, 5 parameter — Provide short-circuit current and open-circuit voltage that the block converts to an equivalent circuit model of the solar cell. This is the default option.

- By equivalent circuit parameters, 5 parameters — Provide electrical parameters for an equivalent circuit model of the solar cell using the 5-parameter solar cell model that makes the following assumptions:
 - The saturation current of the second diode is zero.
 - The parallel resistor has infinite impedance.
- By equivalent circuit parameters, 8 parameters — Provide electrical parameters for an equivalent circuit model of the solar cell using the 8-parameter solar cell model.

Short-circuit current, I_{sc}

The current that flows when you short-circuit the solar cell. This parameter is only visible when you select **By s/c current and o/c voltage**, 5 parameter for the **Parameterize by** parameter . The default value is 7.34 A.

Open-circuit voltage, V_{oc}

The voltage across the solar cell when it is not connected. This parameter is only visible when you select **By s/c current and o/c voltage**, 5 parameter for the **Parameterize by** parameter . The default value is 0.6 V.

Diode saturation current, I_s

The asymptotic reverse current of the first diode for increasing reverse bias in the absence of any incident light. This parameter is only visible when you select one of the following settings:

- By equivalent circuit parameters, 5 parameters for the **Parameterize by** parameter
- By equivalent circuit parameters, 8 parameters for the **Parameterize by** parameter

The default value is $1e-06$ A.

Diode saturation current, I_{s2}

The asymptotic reverse current of the second diode for increasing reverse bias in the absence of any incident light. This parameter is only visible when you select **By equivalent**

circuit parameters, 8 parameters for the **Parameterize by** parameter. The default value is 0 A.

Solar-generated current, I_{ph0}

The solar-induced current when the irradiance is I_{r0} . This parameter is only visible when you select one of the following settings:

- By equivalent circuit parameters, 5 parameters for the **Parameterize by** parameter
- By equivalent circuit parameters, 8 parameters for the **Parameterize by** parameter

The default value is 7.34 A.

Irradiance used for measurements, I_{r0}

The irradiance that produces a current of I_{ph0} in the solar cell. The default value is 1000 W/m².

Quality factor, N

The emission coefficient of the first diode. The default value is 1.5.

Quality factor, $N2$

The emission coefficient of the second diode. This parameter is only visible when you select **By equivalent circuit parameters**, 8 parameters for the **Parameterize by** parameter. The default value is 2.

Series resistance, R_s

The internal series resistance. The default value is 0 Ω .

Parallel resistance, R_p

The internal parallel resistance. This parameter is only visible when you select **By equivalent circuit parameters**, 8 parameters for the **Parameterize by** parameter. The default value is inf Ω .

Solar Cell

Temperature Tab

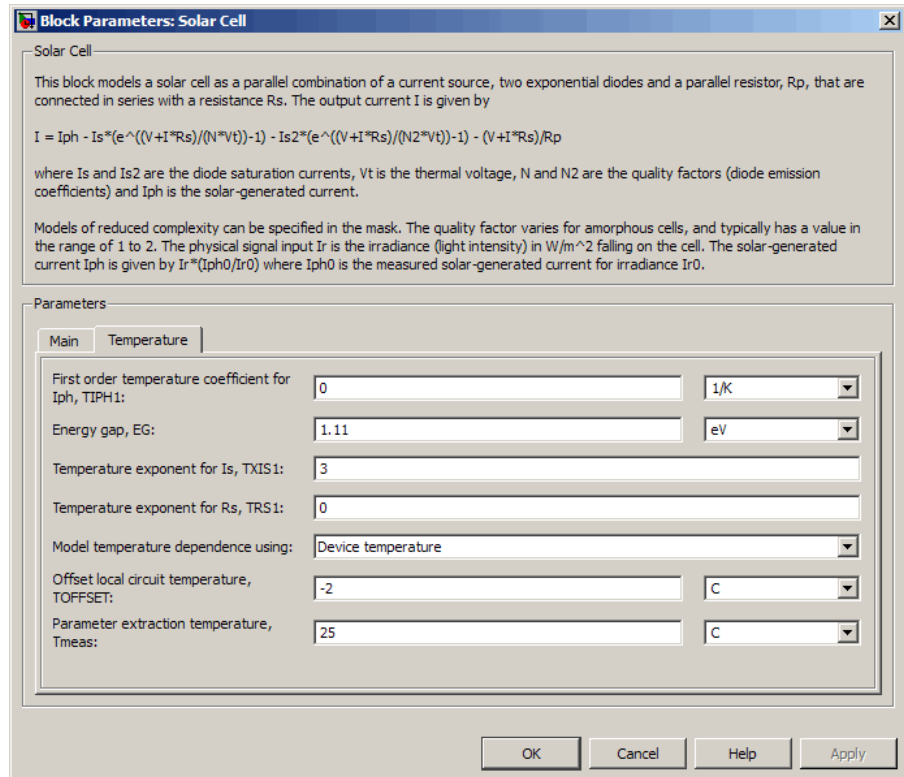

First order temperature coefficient for I_{ph} , TIPH1

The order of the linear increase in the solar-generated current as temperature increases. The default value is 0 1/K. The value must be greater than or equal to 0.

Energy gap, EG

The solar cell activation energy. The default value is 1.11 eV. The value must be greater than or equal to the **Minimum energy gap EGMIN** parameter of the SPICE Environment Parameters block, whose default value is 0.1.

Temperature exponent for I_s , TXIS1

The order of the exponential increase in the current from the first diode as temperature increases. The default value is 3. The value must be greater than or equal to 0.

Temperature exponent for I_{s2} , TXIS2

The order of the exponential increase in the current from the second diode as temperature increases. The default value is 3. This parameter is only visible when you select **By equivalent circuit parameters**, 8 parameters for the **Parameterize by** parameter. The value must be greater than or equal to 0.

Temperature exponent for R_s , TRS1

The order of the exponential increase in the series resistance as temperature increases. The default value is 0. The value must be greater than or equal to 0.

Temperature exponent for R_p , TRP1

The order of the exponential increase in the parallel resistance as temperature increases. The default value is 0. This parameter is only visible when you select 8 parameters for the **Solar cell model parameter**. The value must be greater than or equal to 0.

Model temperature dependence using

Select one of the following options for modeling the solar cell temperature dependence:

- **Device temperature** — Use the device temperature, which is the **Circuit temperature** parameter value (from the SPICE Environment Parameters block, if one exists in the circuit, or the default value for this block otherwise) plus the **Offset local circuit temperature, TOFFSET** parameter value.
- **Fixed temperature** — Use a temperature that is independent of the circuit temperature to model temperature dependence.

Offset local circuit temperature, TOFFSET

The amount by which the solar cell temperature differs from the circuit temperature. This parameter is only visible when

Solar Cell

you select `Device temperature` for the **Model temperature dependence using** parameter. The default value is -2 C.

Parameter extraction temperature, TMEAS

The temperature at which the solar cell parameters were measured. The default value is 25 C. The value must be greater than 0.

Fixed circuit temperature, TFIXED

The temperature at which to simulate the solar cell. This parameter is only visible when you select `Fixed temperature` for the **Model temperature dependence using** parameter. The default value is 25 C. The value must be greater than 0.

Ports

The block has the following ports:

- Ir
Incident irradiance.
- +
- Positive electrical voltage.
-
- Negative electrical voltage.

References

[1] Gow, J.A. and C.D. Manning. "Development of a Photovoltaic Array Model for Use in Power-Electronics Simulation Studies." IEE Proceedings of Electric Power Applications, Vol. 146, No. 2, pp. 193–200, March 1999.

Purpose Model electrical characteristics and generated force of solenoid

Library Actuators & Drivers

Description The Solenoid block represents the electrical characteristics and generated force for the solenoid in the following figure:

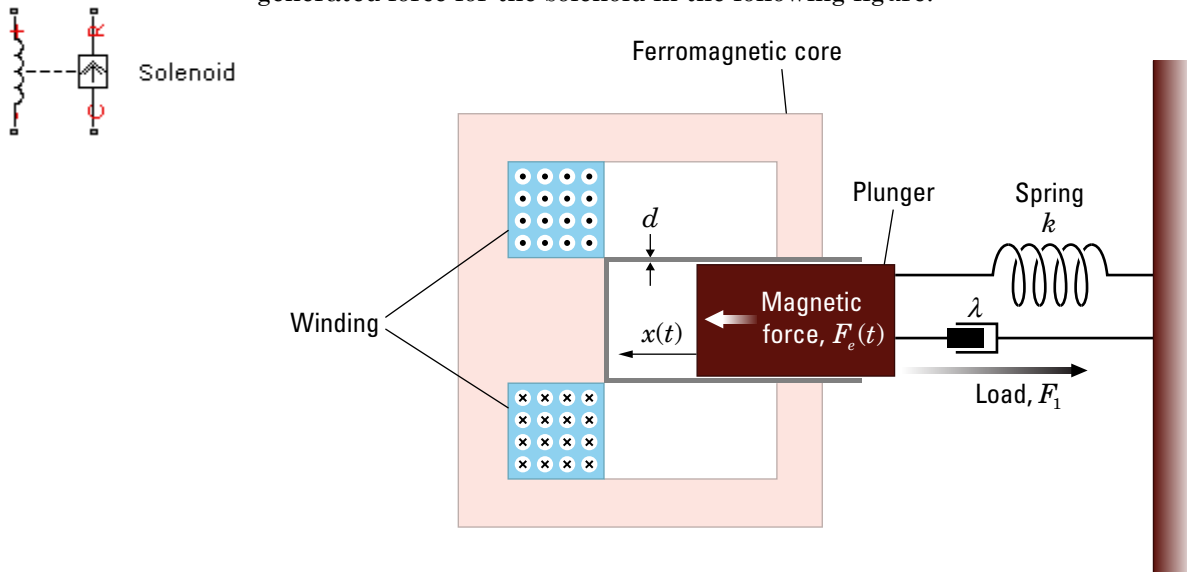

The return spring is optional. To remove the effects of this spring from the model, set the **Spring constant** parameter to 0.

The equation of motion for the plunger as a function of position, x , is:

$$F_l + m\ddot{x} + \lambda\dot{x} + kx = F_e$$

where F_e is the electromagnetic force, F_l is the load force, λ is the viscous damping term and m is the plunger mass. The electromagnetic force is related to the solenoid current and inductance by:

$$F_e = \frac{1}{2}i^2 \frac{\partial L(x)}{\partial x}$$

Solenoid

The inductance, which is derived in [1], can be written as:

$$\frac{\partial L(x)}{\partial x} = \frac{-\beta}{(\alpha + \beta x)^2}$$

where α and β are constants. Plugging the preceding equation into the equation for electromagnetic force gives the force-stroke relationship of the solenoid for a current i_0 :

$$F = \frac{1}{2} i_0^2 \frac{-\beta}{(\alpha + \beta x)^2}$$

The Solenoid block solves for α and β by taking the two specified force and stroke measurements and substituting them into the preceding equation. It solves the resulting equations for α and β .

A positive current from the electrical + to - ports creates a negative force (i.e., a pulling force) from the mechanical C to R ports.

Dialog Box and Parameters

Magnetic Force Tab

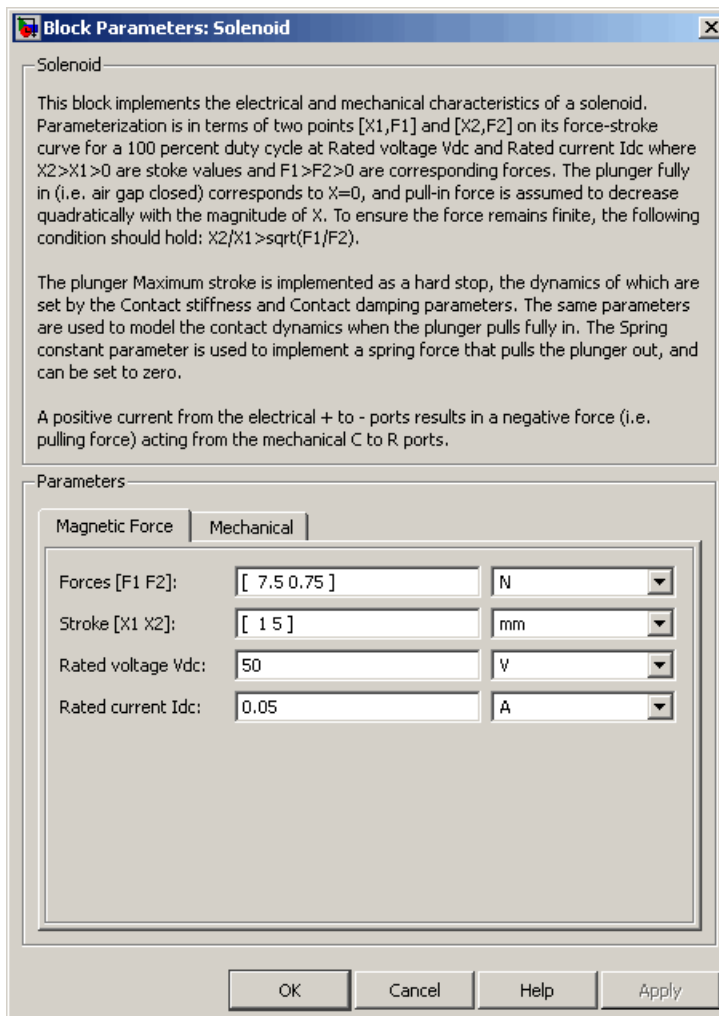

Solenoid

Forces [F1 F2]

A vector of the force values at the two points on the force-stroke curve. The second measurement point must be at a stroke that is greater than that of the first measurement point. When the manufacturer doesn't provide a force-stroke curve, set F1 to the holding torque (when X1 = 0) and F2 to the pull-in torque when running the solenoid at the **Rated voltage Vdc** and **Rated current Idc** values. The default value is [7.5 0.75] N.

Stroke [X1 X2]

A vector of the stroke (plunger distance from the fully closed position) values at the two points on the force-stroke curve. The second measurement point must be at a stroke that is greater than that of the first measurement point. To ensure a finite force value, the points must meet the condition

$$\frac{X2}{X1} > \sqrt{\frac{F1}{F2}}$$

The default value is [1 5] mm.

Rated voltage Vdc

The voltage at which the solenoid is rated to operate. This voltage value is used to measure the **Forces [F1 F2]** and **Stroke [X1 X2]** values. The default value is 50 V.

Rated current Idc

The current that flows when the solenoid is supplied with the **Rated voltage Vdc** voltage. The default value is 0.05 A.

Mechanical Tab

Block Parameters: Solenoid

Solenoid

This block implements the electrical and mechanical characteristics of a solenoid. Parameterization is in terms of two points $[X1, F1]$ and $[X2, F2]$ on its force-stroke curve for a 100 percent duty cycle at Rated voltage V_{dc} and Rated current I_{dc} where $X2 > X1 > 0$ are stroke values and $F1 > F2 > 0$ are corresponding forces. The plunger fully in (i.e. air gap closed) corresponds to $X=0$, and pull-in force is assumed to decrease quadratically with the magnitude of X . To ensure the force remains finite, the following condition should hold: $X2/X1 > \sqrt{F1/F2}$.

The plunger Maximum stroke is implemented as a hard stop, the dynamics of which are set by the Contact stiffness and Contact damping parameters. The same parameters are used to model the contact dynamics when the plunger pulls fully in. The Spring constant parameter is used to implement a spring force that pulls the plunger out, and can be set to zero.

A positive current from the electrical + to - ports results in a negative force (i.e. pulling force) acting from the mechanical C to R ports.

Parameters

Magnetic Force **Mechanical**

Spring constant:	200	N/m
Stroke for zero spring force:	5	mm
Damping:	1	N/(m/s)
Plunger mass:	0.05	kg
Maximum stroke:	Inf	mm
Initial plunger position:	5	mm
Contact stiffness:	1e+06	N/m
Contact damping:	500	N/(m/s)

OK Cancel Help Apply

Solenoid

Spring constant

Constant representing the stiffness of the spring that acts to retract the plunger when the solenoid is powered off. The force is zero when the plunger is displaced to the **Stroke for zero spring force** parameter value. The default value is 200 N/m. Set the spring constant to zero if there is no spring.

Stroke for zero spring force

The stroke at which the spring provides no force. The default value is 5 mm.

Damping

The term λ in the equation of motion for the plunger as a function of position that linearly damps the plunger motion. The default value is 1 N/(m/s). The value can be zero.

Plunger mass

The weight of the solenoid plunger. The default value is 0.05 kg. The value can be zero.

Maximum stroke

The maximum amount by which the plunger can be displaced. You can use this parameter to model a hard endstop that limits the stroke. The default value is Inf mm, which means no stroke limit.

Initial plunger position

The amount by which the plunger is displaced at the start of the simulation. The default value is 0 m.

Contact stiffness

Stiffness of the plunger contact that models the hard stop at the minimum ($x = 0$) and maximum ($x = \mathbf{Maximum\ stroke}$) plunger positions. The default value is 1e+06 N/m.

Contact damping

Damping of the plunger contact that models the hard stop at the minimum ($x = 0$) and maximum ($x = \mathbf{Maximum\ stroke}$) plunger positions. The default value is 150 N/(m/s).

Ports

The block has the following ports:

- + Positive electrical input.
- Negative electrical input.
- C Mechanical translational conserving port.
- R Mechanical translational conserving port.

References

- [1] S.E. Lyshevski. *Electromechanical Systems, Electric Machines, and Applied Mechatronics* CRC, 1999.

SPICE Environment Parameters

Purpose Set parameters that apply to all connected SPICE-compatible blocks

Library Utilities

Description The SPICE Environment Parameters block lets you set parameters that apply to all SPICE-compatible blocks in an electrical network:



SPICE Environment
Parameters

- Circuit temperature
- Minimum conductance

If your Simulink® model does not contain a SPICE Environment Parameters block, all blocks use the default values of these parameters. You must connect every network in the system to a SPICE Environment Parameters block to override the default values.

Note The simple semiconductor models in the Semiconductors sublibrary are not temperature dependent, so the SPICE Environment Parameters block only changes the minimum conductance parameter used by the exponential diode and bipolar transistor models.

Dialog Box and Parameters

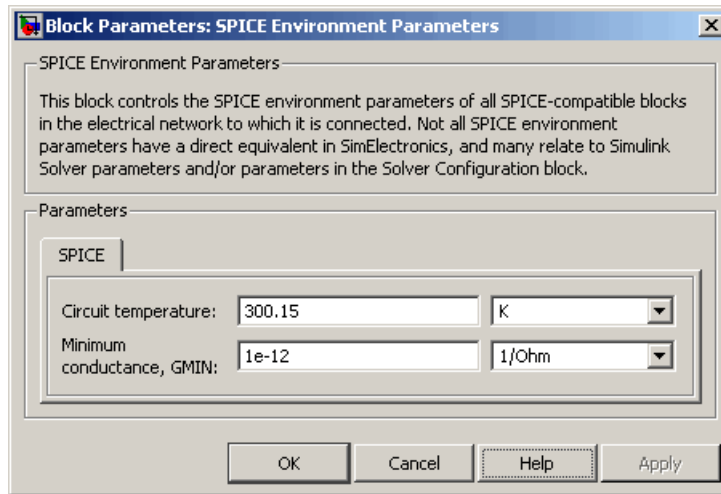

Circuit temperature

The temperature of the connected SPICE-compatible blocks. The default value is 300.15 K.

Minimum conductance GMIN

The minimum conductance used by some blocks. The default value is 1e-12 1/Ω.

Ports

The block has the following ports:

OUT

Electrical output.

Stepper Motor

Purpose

Model stepper motor

Library

Actuators & Drivers

Description

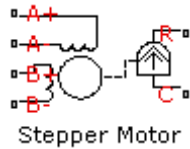

The Stepper Motor block represents a stepper motor. It uses the input pulse trains, A and B, to control the mechanical output according to the following equations:

$$\frac{di_A}{dt} = (v_A - Ri_A + K_m \omega \sin(N_r \theta)) / L$$

$$\frac{di_B}{dt} = (v_B - Ri_B - K_m \omega \cos(N_r \theta)) / L$$

$$\frac{d\omega}{dt} = (-K_m i_a \sin(N_r \theta) + K_m i_b \cos(N_r \theta) - B\omega) / J$$

$$\frac{d\theta}{dt} = \omega$$

where:

- i_A and i_B are the A and B phase winding currents.
- v_A and v_B are the A and B phase winding voltages.
- K_m is the motor torque constant.
- N_r is the number of teeth on each of the two rotor poles. The **Full step size** parameter is $(\pi/2)/N_r$.
- R is the winding resistance.
- L is the winding inductance.
- B is the rotational damping.
- J is the inertia.

If the initial rotor is zero or some multiple of $(\pi/2)/N_p$, the rotor is aligned with the phase winding of pulse A. This happens when there is a positive current flowing from the A+ to the A- ports and there is no current flowing from the B+ to the B- ports.

Use the Stepper Motor Driver block to create the pulse trains for the Stepper Motor block.

The Stepper Motor block produces a positive torque acting from the mechanical C to R ports when the phase of pulse A leads the phase of pulse B.

Basic Assumptions and Limitations

The model is based on the following assumptions:

- This model neglects magnetic saturation effects, detent torque, and any magnetic coupling between phases.
- When you select the **Start simulation from steady state** check box in the Simscape Solver Configuration block, this block will not initialize an **Initial rotor angle** value between $-\pi$ and π .

Stepper Motor

Dialog Box and Parameters

Electrical Torque Tab

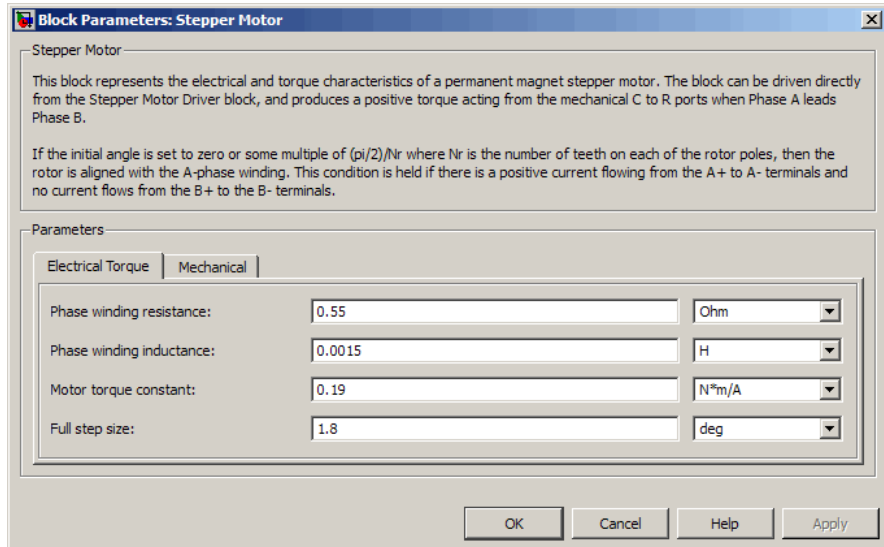

Phase winding resistance

Resistance of the A and B phase windings. The default value is 0.55 Ω .

Phase winding inductance

Inductance of the A and B phase windings. The default value is 0.0015 H.

Motor torque constant

Motor torque constant K_m . The default value is 0.19 N*m/A.

Full step size

Step size when changing the polarity of either the A or B phase current. The default value is 1.8°.

Mechanical Tab

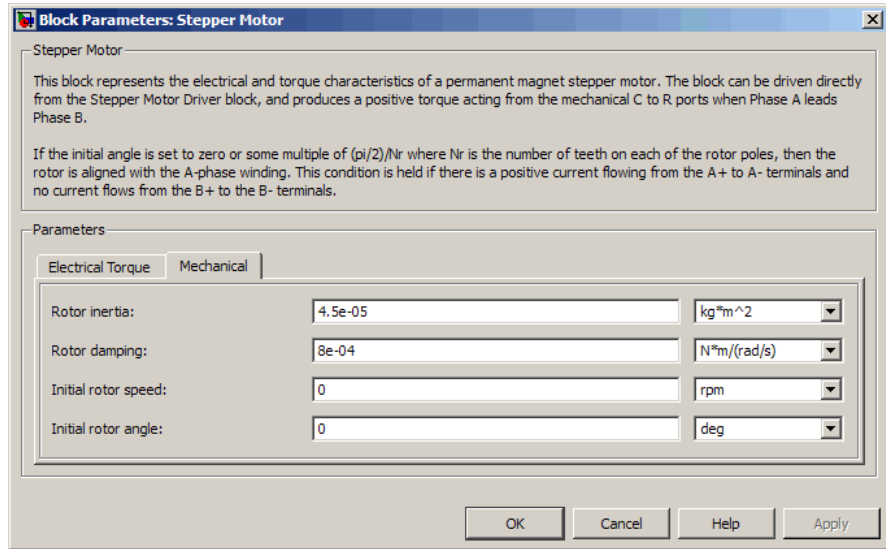

Rotor inertia

Resistance of the rotor to change in motor motion. The default value is $4.5e-05 \text{ kg}\cdot\text{m}^2$. The value can be zero.

Rotor damping

Energy dissipated by the rotor. The default value is $8e-04 \text{ N}\cdot\text{m}/(\text{rad}/\text{s})$. The value can be zero.

Initial rotor speed

Speed of the rotor at the start of the simulation. The default value is 0 rpm.

Initial rotor angle

Angle of the rotor at the start of the simulation. The default value is 0 rad.

Ports

The block has the following ports:

Stepper Motor

A+	Positive electrical output of pulse A.
A-	Negative electrical output of pulse A
B+	Positive electrical output of pulse B.
B-	Negative electrical output of pulse B.
C	Mechanical rotational conserving port.
R	Mechanical rotational conserving port.

Examples

See the Controlled Stepper Motor demo.

References

- [1] M. Bodson, J. N. Chiasson, R. T. Novotnak and R. B. Rekowski. "High-Performance Nonlinear Feedback Control of a Permanent Magnet Stepper Motor." IEEE Transactions on Control Systems Technology, Vol. 1, No. 1, March 1993.
- [2] P. P. Acarnley. *Stepping Motors: A Guide to Modern Theory and Practice*. New York: Peregrinus, 1982.
- [3] S.E. Lyshevski. *Electromechanical Systems, Electric Machines, and Applied Mechatronics*. CRC, 1999.

See Also

Stepper Motor Driver

Purpose Model stepper motor driver

Library Actuators & Drivers

Description

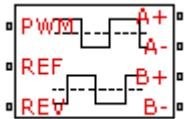

Stepper Motor Driver

The Stepper Motor Driver block represents a stepper motor driver. It creates the pulse trains, A and B, required to control the motor. This block initiates a step each time the voltage at the PWM port rises above the **Enable threshold voltage**.

If the voltage at the REV port is less than or equal to the **Reverse threshold voltage**, pulse A leads pulse B by 90 degrees. If the voltage at the REV port is greater than the **Reverse threshold voltage**, pulse B leads pulse A by 90 degrees and the motor direction is reversed.

At time zero, pulse A is positive and pulse B is negative.

Use the Controlled PWM Voltage block to create the voltage at the PWM port. This block creates a network engine event every time the PWM signal goes high. The network engine event triggers a simulation time point when the PWM signal goes high, which ensures good simulation accuracy. If you instead use the Controlled Voltage Source block from the Foundation library, which is controlled by Simulink, you need to set a suitably small time step for the simulation. For information about specifying the Simulink step size, see “Choosing a Solver” in the Simulink User’s Guide.

Stepper Motor Driver

Dialog Box and Parameters

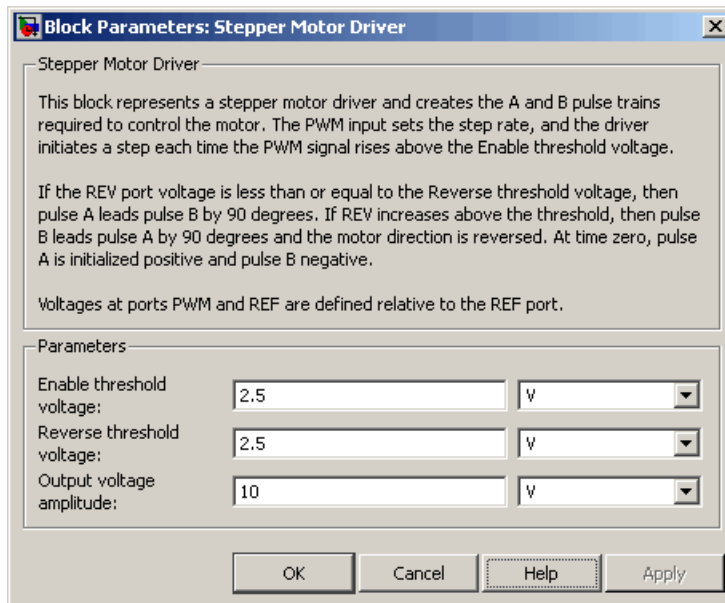

Enable threshold voltage

When the voltage at the PWM port rises above this threshold, the Stepper Motor Driver block initiates a step. The default value is 2.5 V.

Reverse threshold voltage

When the voltage at the REV port rises above this threshold, pulse B leads pulse A by 90 degrees and the motor direction is reversed. The default value is 2.5 V.

Output voltage amplitude

Amplitude of the output pulse trains. The default value is 10 V.

Ports

The block has the following ports:

A+

Positive electrical output of pulse A.

- A- Negative electrical output of pulse A
- B+ Positive electrical output of pulse B.
- B- Negative electrical output of pulse B.
- PWM Triggering input step voltage.
- REF Input floating reference voltage.
- REV Input voltage that controls motor direction.

Examples

See the Controlled Stepper Motor demo.

See Also

Controlled PWM Voltage and Stepper Motor.

Strain Gauge

Purpose Model deformation sensor

Library Sensors

Description The Strain Gauge block represents a sensor that generates a change in resistance as a function of strain using the following equation:

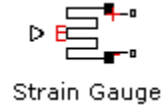

$$\frac{\Delta R}{R} = K\varepsilon$$

where:

- $\Delta R/R$ is the fractional change in resistance.
- ε is the strain at port B.
- K is the **Gauge factor** parameter value.

Dialog Box and Parameters

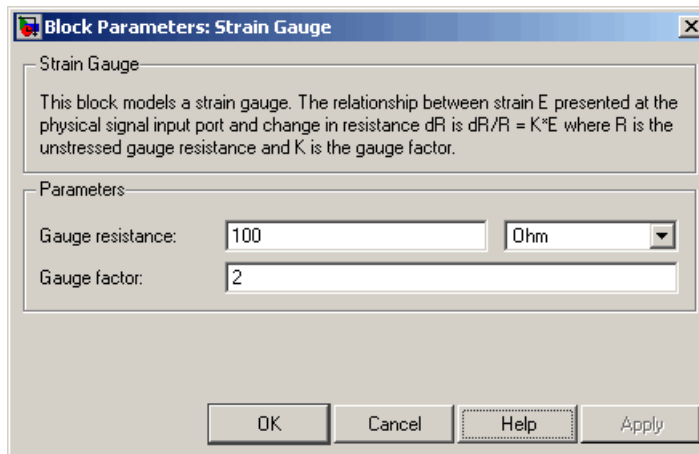

Gauge resistance

The unstressed gauge resistance. The default value is 100 Ω .

Gauge factor

The ratio K of the fractional change in resistance to the fractional change in length. The default value is 2.

Ports

The block has the following ports:

- B
Strain input.
- +
- Positive electrical port.
-
- Negative electrical port.

Timer

Purpose

Model timer integrated circuit behaviorally

Library

Integrated Circuits

Description

The Timer block is a behavioral model of a timer integrated circuit such as the NE555.

The following figure shows the implementation structure.

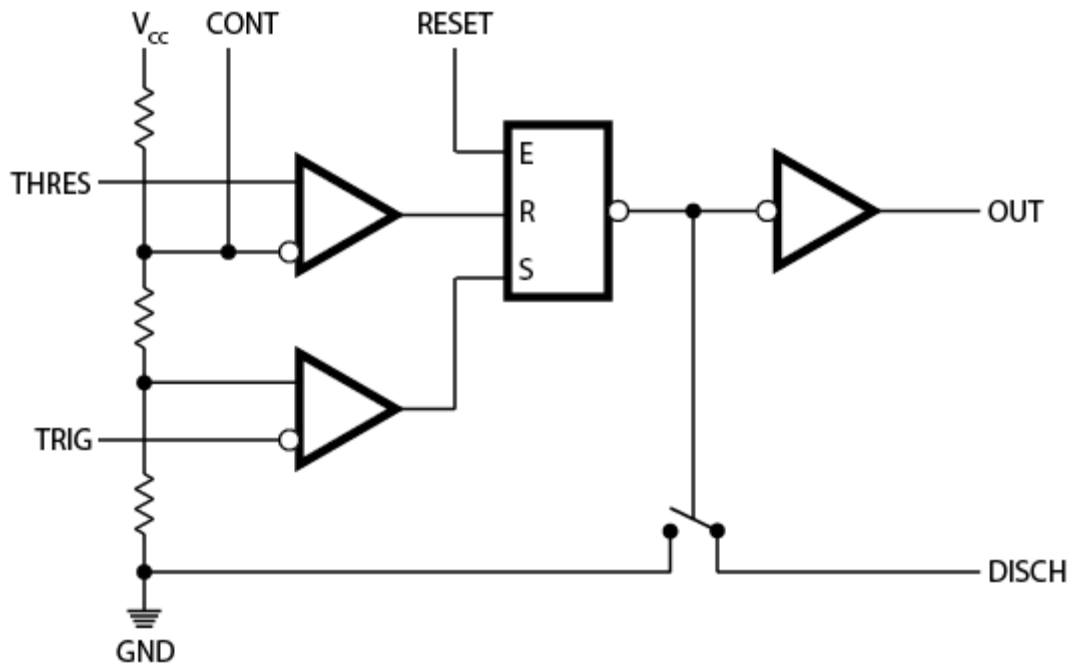

The **Potential divider component resistance** parameter sets the values of the three resistors creating the potential divider. The two comparator inputs have infinite input resistance and zero input capacitance. The S-R Latch block provides the functionality of the set-reset latch. It includes an output capacitor and a resistor with values set to match the **Propagation delay** parameter value. The block models the output stage inverter using a SimElectronics CMOS

NOT block. You define the output resistance, low-level output voltage, and high-level output voltage for the CMOS gate in the Timer block dialog box. The discharge switch approximates the NPN bipolar transistor on a real timer as a switch with defined switch on-resistance and off-resistance values.

Basic Assumptions and Limitations

This block has the following limitations:

- The behavior is abstracted. Results are not as accurate as a transistor-level model.
- Delay in response to changing inputs depends solely upon the RC time constant of the resistor-capacitor network at the output of the latch. In practice, the delay has a more complex dependency on the device structure. Set this value based on the output-pulse rise and fall times.
- The drop in output voltage is a linear function of output current. In practice, the relationship is that of a bipolar transistor push-pull pair.
- The controlled switch arrangement used by the block is an approximation of an open-collector arrangement.
- The power supply connects internally within the component, and the block assumes that the GND pin is grounded.

Timer

Dialog Box and Parameters

Supply Tab

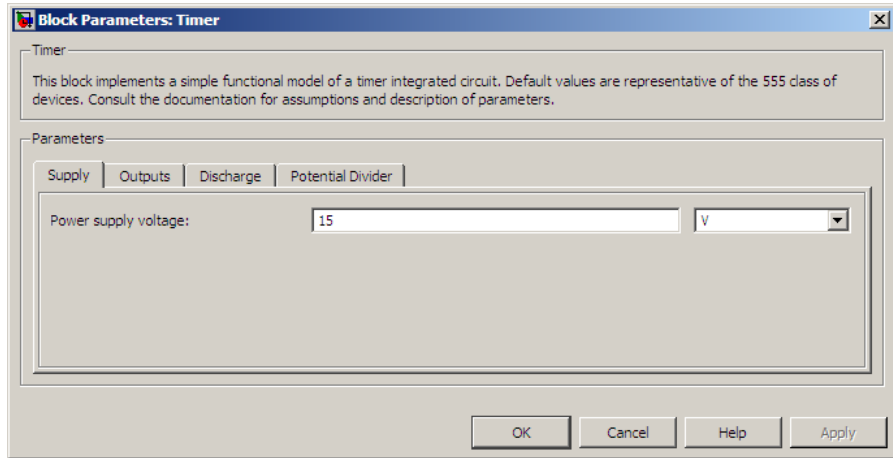

Power supply voltage

The voltage value V_{cc} that the block applies internally to the timer component. The default value is 15 V.

Outputs Tab

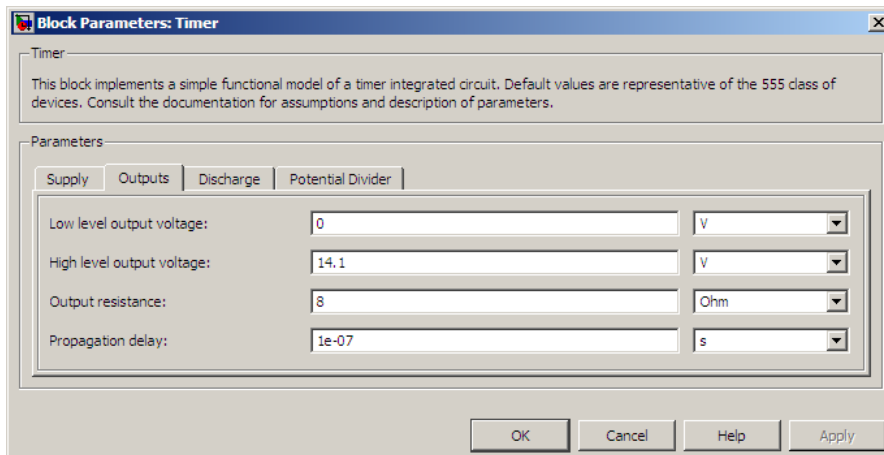

Low level output voltage

The output voltage when the timer output is low and no output current is drawn. The default value is 0 V.

High level output voltage

The output voltage V_{OH} when the timer output is high and no current is drawn. The default value is 14.1 V.

Output resistance

The ratio of output voltage drop to output current. Set this parameter to $(V_{OH} - V_{OH1}) / I_{OH1}$, where V_{OH1} is the reduced output high voltage when the output current is I_{OH1} . The default value is 8 Ω .

Propagation delay

Set this value to the input-pulse or output-pulse rise time. The default value is 1e-07 s.

Discharge Tab

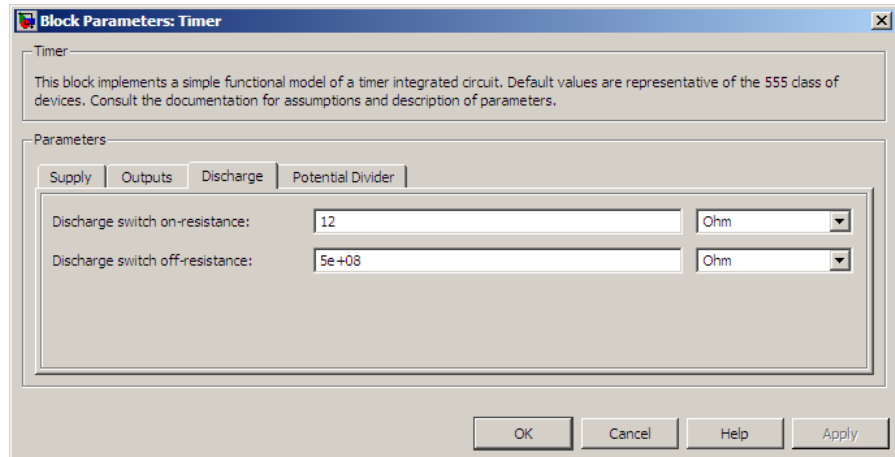

Discharge switch on-resistance

A representative value is the discharge pin saturation voltage divided by the corresponding current. The default value is 12 Ω .

Discharge switch off-resistance

A representative value is the discharge pin leakage current divided by the corresponding pin voltage. The default value is 5e+08 Ω .

Potential Divider Tab

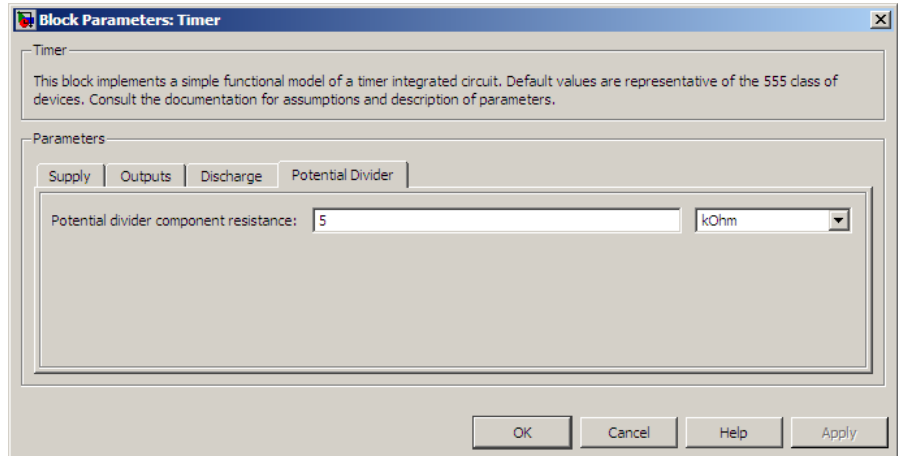

Potential divider component resistance

A typical value for a 555-type timer is 5 k Ω . You can measure it directly across the positive supply and control pins when the chip does not connect to a circuit. The default value is 5 k Ω .

Ports

This block has the following ports:

THRES

Electrical port corresponding to the threshold pin.

TRIG

Electrical port corresponding to the trigger pin.

CONT

Electrical port corresponding to the control pin.

RESET

Electrical port corresponding to the reset pin.

OUT

Electrical port corresponding to the output pin.

Timer

DISCH

Electrical port corresponding to the discharge pin.

See Also

S-R Latch and Comparator.

Purpose

Model resistor with thermal port

Library

Passive Devices

Description

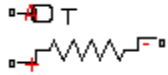

Thermal Resistor

The Thermal Resistor block represents a temperature-dependent resistor. The resistance when the temperature at the thermal port is T is

$$R = R_0(1 + \alpha(T - T_0))$$

where:

- R_0 is the nominal resistance at the reference temperature T_0 .
- α is the temperature coefficient.

The following equation describes the thermal behavior of the block:

$$Q = K_d t_c \frac{dT}{dt}$$

where:

- Q is the net heat flow into port A.
- K_d is the **Dissipation factor** parameter value.
- t_c is the **Thermal time constant** parameter value.
- dT/dt is the rate of change of the temperature.

Thermal Resistor

Dialog Box and Parameters

Electrical Tab

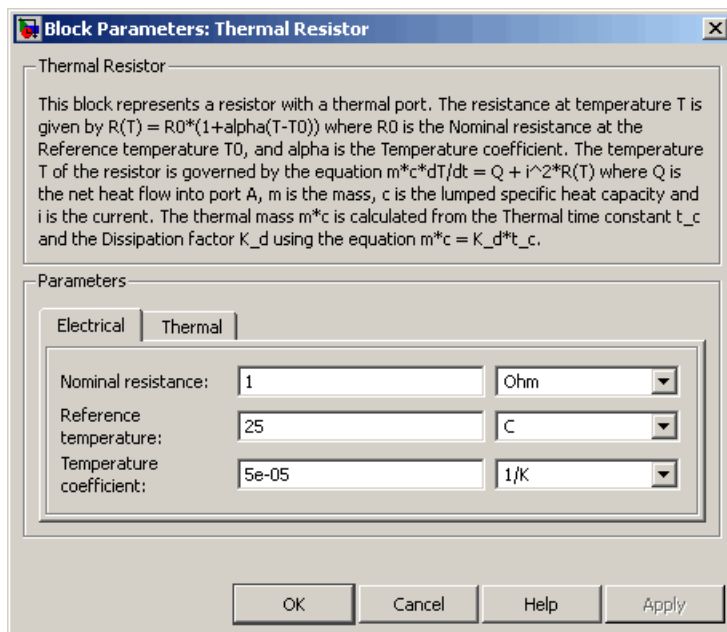

Nominal resistance

The nominal resistance of the thermistor at the reference temperature. Many datasheets quote the nominal resistance at 25°C and list it as R25. The default value is 1 Ω.

Reference temperature

The temperature at which the nominal resistance was measured. The default value is 25 °C.

Temperature coefficient

The coefficient α in the equation that describes resistance as a function of temperature. The default value is 5e-05 1/K.

Thermal Tab

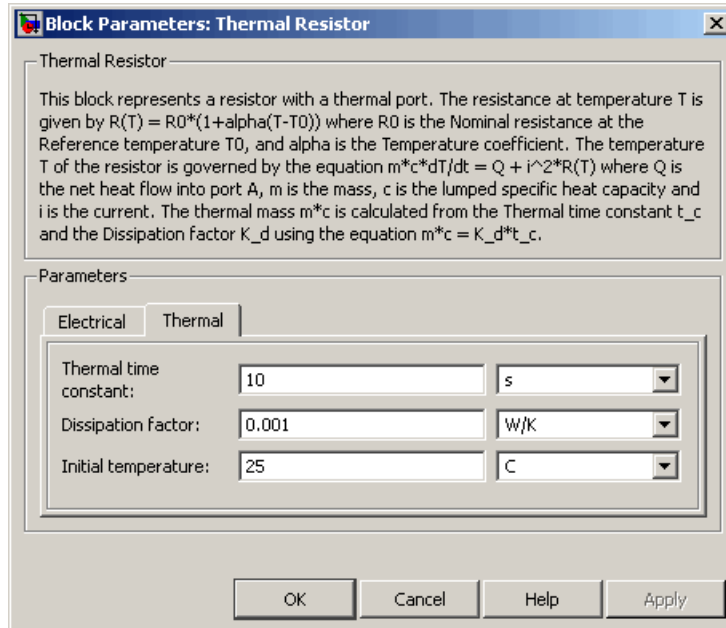

Thermal time constant

The time it takes the resistor temperature to reach 63% of the final temperature change when a step change in ambient temperature occurs. The default value is 10 s.

Dissipation factor

The thermal power required to raise the thermal resistor temperature by one K. The default value is 0.001 W/K.

Initial temperature

The temperature of the thermal resistor at the start of the simulation. The default value is 25 °C.

Ports

The block has the following ports:

Thermal Resistor

- A Resistor thermal port.
- + Positive electrical port.
- Negative electrical port.

See Also Thermistor, Thermocouple.

Purpose Model NTC thermistor using B-parameter equation

Library Sensors

Description The Thermistor block represents an NTC thermistor using the B-parameter equation. The resistance at temperature T is

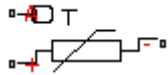

Thermistor

$$R = R_0 (e^{B(1/T - 1/T_0)} - 1)$$

where:

- R_0 is the nominal resistance at the reference temperature T_0 .
- B is the characteristic temperature constant.

The following equation describes the thermal behavior of the block:

$$Q = K_d t_c \frac{dT}{dt}$$

where:

- Q is the net heat flow into port A.
- K_d is the **Dissipation factor K_d** parameter value.
- t_c is the **Thermal time constant t_c** parameter value.
- dT/dt is the rate of change of the temperature.

To model the thermistor in free space:

- 1 Connect the thermistor to the B port of a Simscape Convective Heat Transfer block.
- 2 Connect the A port of the Convective Heat Transfer block to a Simscape Ideal Temperature Source block whose temperature is set to the ambient temperature.

Thermistor

- 3 Set the **Area** parameter of the Convective Heat Transfer block to an approximate area A_{nom} .
- 4 Set the **Heat transfer coefficient** parameter of the Convective Heat Transfer block to K_d/A_{nom} .

Dialog Box and Parameters

Electrical Tab

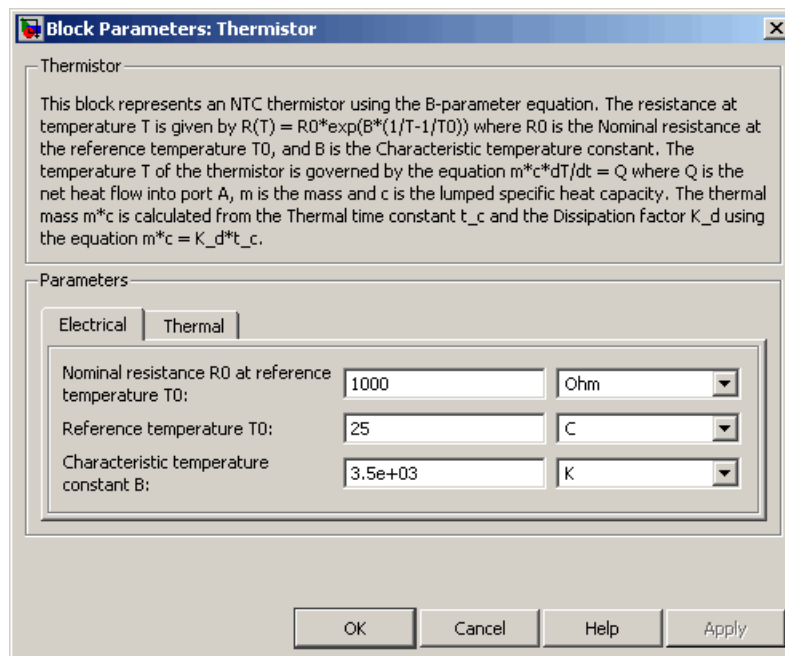

Nominal resistance R0 at reference temperature T0

The nominal resistance of the thermistor at the reference temperature. Many datasheets quote the nominal resistance at 25°C and list it as R25. The default value is 1000 Ω.

Reference temperature T_0

The temperature at which the nominal resistance was measured.
The default value is 25 °C.

Characteristic temperature constant B

The coefficient B in the equation that describes resistance as a function of temperature. The default value is 3.5e+03 K.

Thermal Tab

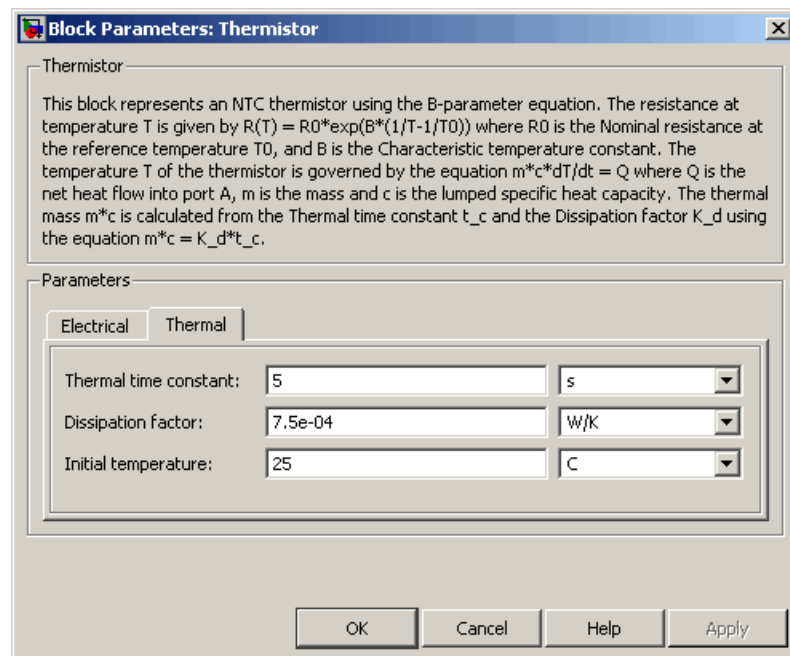

Thermal time constant

The time it takes the sensor temperature to reach 63% of the final temperature change when a step change in ambient temperature occurs. The default value is 5 s.

Thermistor

Dissipation factor

The thermal power required to raise the thermistor temperature by one K. The default value is $7.5e-04$ W/K.

Initial temperature

The temperature of the thermistor at the start of the simulation. The default value is 25 °C.

Ports

The block has the following ports:

- A Thermal port.
- + Positive electrical port.
- Negative electrical port.

See Also

Thermal Resistor

Purpose

Model sensor that converts thermal potential difference into electrical potential difference

Library

Sensors

Description

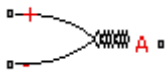

Thermocouple

The Thermocouple block represents a thermocouple using the standard polynomial parameterization defined in the NIST ITS-90 Thermocouple Database [1]. The voltage E across the device in mV is

$$E(\text{mV}) = c_0 + c_1*t + \dots + c_n*t^n$$

where:

- c_i is the i^{th} element of the **Coefficients [c0 c1 ... cn]** parameter value.
- t is the temperature difference in degrees Celsius between the temperature at the thermal port A and the **Reference temperature** parameter value.

Note The equation for voltage across the device as a function of temperature difference is defined in mV. The units of the voltage across the actual device is V.

The following equation describes the thermal behavior of the block:

$$Q = K_d t_c \frac{dT}{dt}$$

where:

- T is the temperature at port A.
- Q is the net heat flow into port A.
- K_d is the **Dissipation factor** parameter value.

Thermocouple

- t_c is the **Thermal time constant** parameter value.
- dT/dt is the rate of change of the temperature.

To model the thermocouple in free space:

- 1** Connect the thermocouple to the B port of a Simscape Convective Heat Transfer block.
- 2** Connect the A port of the Convective Heat Transfer block to a Simscape Ideal Temperature Source block whose temperature is set to the ambient temperature.
- 3** Set the **Area** parameter of the Convective Heat Transfer block to an approximate area A_{nom} .
- 4** Set the **Heat transfer coefficient** parameter of the Convective Heat Transfer block to K_d/A_{nom} .

Basic Assumptions and Limitations

The model is based on the following assumptions:

- The high-order polynomials this block uses are very sensitive to the number of significant figures used for computation. Use all available significant figures when specifying the **Coefficients [c0 c1 ... cn]** parameter.
- **Coefficients [c0 c1 ... cn]** are defined for use over a specified temperature range.
- This block does not include the additional exponential term that Type K thermocouples use when parameterized for $t > 0$.

Dialog Box and Parameters

Electrical Tab

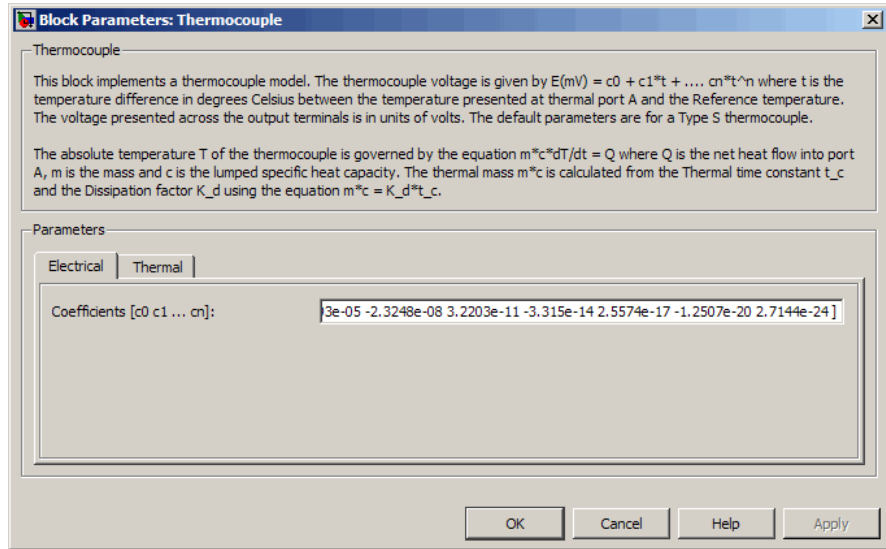

Coefficients [c0 c1 ... cn]

The vector of coefficients c in the equation that describes voltage as a function of temperature. The default value is [0 0.0054031 1.2593e-05 -2.3248e-08 3.2203e-11 -3.315e-14 2.5574e-17 -1.2507e-20 2.7144e-24]. This value specifies a Type S thermocouple, which is valid in the range -50 to 1064 degrees C.

Note You can download parameters for other standard thermocouple types from the NIST database [1]. For a demo of how to do this, see the Simulink Approximating Nonlinear Relationships: Type S Thermocouple demo, `sldemo_tc_script.m`, and the associated model file, `sldemo_tc.mdl`.

Thermocouple

Thermal Tab

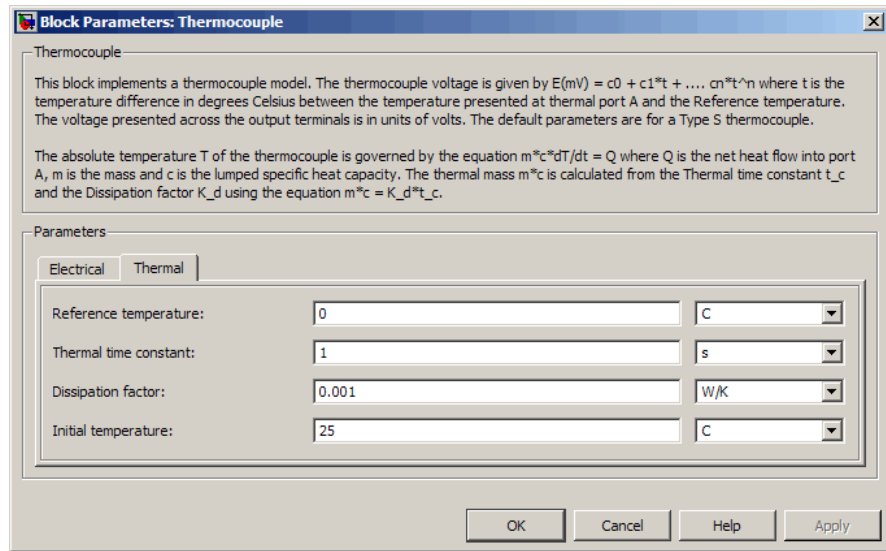

Reference temperature

The temperature the block subtracts from the temperature at the thermal port in calculating the voltage across the device. The default value is 0 °C.

Thermal time constant

The time it takes the thermocouple temperature to reach 63% of the final temperature change when a step change in ambient temperature occurs. The default value is 1 s.

Dissipation factor

The thermal power required to raise the thermocouple temperature by one K. The default value is 0.001 W/K.

Initial temperature

The temperature of the thermocouple at the start of the simulation. The default value is 25 °C.

Ports

The block has the following ports:

- A Thermocouple thermal port.
- + Positive electrical port.
- Negative electrical port.

References

[1] NIST ITS-90 Thermocouple Database
<http://srdata.nist.gov/its90/main>

See Also

Thermal Resistor.

Three-Winding Mutual Inductor

Purpose Model three coupled inductors

Library Passive Devices

Description

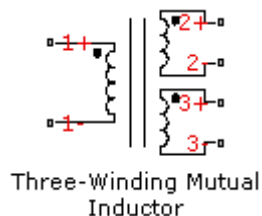

The Three-Winding Mutual Inductor block represents a set of three coupled inductors or windings. The voltage across the three windings is

$$V_1 = L_1 \frac{dI_1}{dt} + M_{12} \frac{dI_2}{dt} + M_{13} \frac{dI_3}{dt}$$

$$V_2 = M_{12} \frac{dI_1}{dt} + L_2 \frac{dI_2}{dt} + M_{23} \frac{dI_3}{dt}$$

$$V_3 = M_{13} \frac{dI_1}{dt} + M_{23} \frac{dI_2}{dt} + L_3 \frac{dI_3}{dt}$$

where:

- V_i is voltage across the i th winding.
- I_i is current through the i th winding.
- L_i is self inductance of the i th winding.
- M_{ij} is mutual inductance of the i th and j th windings, $M_{ij} = K_{ij} \sqrt{L_i L_j}$.

In the preceding equations, currents are positive when flowing into the positive node of their respective inductor terminals.

When you run a simulation that includes this block, the software checks the specified parameter values to ensure that the resulting device is passive. If it is not, the software issues an error.

Three-Winding Mutual Inductor

Dialog Box and Parameters

Block Parameters: Three-Winding Mutual Inductor

Three-Winding Mutual Inductor

This block models three coupled inductors. The following equations describe the voltage-current relationships, where currents are positive when flowing into the positive node of their respective inductor terminals.

$$V1 = L1 \cdot dI1/dt + M12 \cdot dI2/dt + M13 \cdot dI3/dt$$
$$V2 = M12 \cdot dI1/dt + L2 \cdot dI2/dt + M23 \cdot dI3/dt$$
$$V3 = M13 \cdot dI1/dt + M23 \cdot dI2/dt + L3 \cdot dI3/dt$$

where parameters L1, L2 and L3 are the winding self-inductances, and the $M_{i,j}$ s are the mutual inductances. $M_{i,j}$ is defined in terms of the Coefficient of Coupling $K_{i,j}$ using the equation $M_{i,j} = K_{i,j} \cdot \sqrt{L_i \cdot L_j}$. The absolute value of $|K|$ must be less than one and the eigenvalues of above system of equations must be greater than zero.

The parameters IC1, IC2 and IC3 set the initial currents flowing through windings 1, 2 and 3.

Parameters

Inductance L1:	<input type="text" value="0.001"/>	H
Inductance L2:	<input type="text" value="0.001"/>	H
Inductance L3:	<input type="text" value="0.001"/>	H
Coefficient of coupling, K12:	<input type="text" value="0.9"/>	
Coefficient of coupling, K13:	<input type="text" value="0.9"/>	
Coefficient of coupling, K23:	<input type="text" value="0.9"/>	
Specify initial condition?:	<input type="text" value="No"/>	

OK Cancel Help Apply

Inductance L1

The self inductance of the first winding. The default value is 0.001 H.

Three-Winding Mutual Inductor

Inductance L2

The self inductance of the second winding. The default value is 0.001 H.

Inductance L3

The self inductance of the third winding. The default value is 0.001 H.

Coefficient of coupling, K12

The coefficient that defines the mutual inductance between the first and second windings. The default value is 0.9. The absolute value must be between 0 and 1, exclusive.

Coefficient of coupling, K13

The coefficient that defines the mutual inductance between the first and third windings. The default value is 0.9. The absolute value must be between 0 and 1, exclusive.

Coefficient of coupling, K23

The coefficient that defines the mutual inductance between the second and third windings. The default value is 0.9. The absolute value must be between 0 and 1, exclusive.

Specify initial condition

Select one of the following options for specifying an initial condition:

- No — Do not specify an initial condition for the model. This is the default option.
- Yes — Specify the initial inductor currents.

Initial current port 1, IC1

The current flowing through the first winding at the start of the simulation. This parameter is only visible when you select **Yes** for the **Specify initial condition** parameter. The default value is 0 A.

Initial current port 2, IC2

The current flowing through the second winding at the start of the simulation. This parameter is only visible when you select

Three-Winding Mutual Inductor

Yes for the **Specify initial condition** parameter. The default value is 0 A.

Initial current port 3, IC3

The current flowing through the third winding at the start of the simulation. This parameter is only visible when you select Yes for the **Specify initial condition** parameter. The default value is 0 A.

Ports

The block has the following ports:

- 1+ Positive electrical voltage of the first mutual inductor.
- 1- Negative electrical voltage of the first mutual inductor.
- 2+ Positive electrical voltage of the second mutual inductor.
- 2- Negative electrical voltage of the second mutual inductor.
- 3+ Positive electrical voltage of the third mutual inductor.
- 3- Negative electrical voltage of the third mutual inductor.

Universal Motor

Purpose Model electrical and torque characteristics of a universal (or series) motor

Library Actuators & Drivers

Description

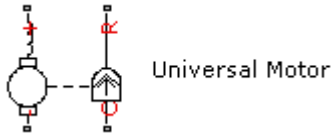

The Universal Motor block represents the electrical and torque characteristics of a universal (or series) motor using the following equivalent circuit model.

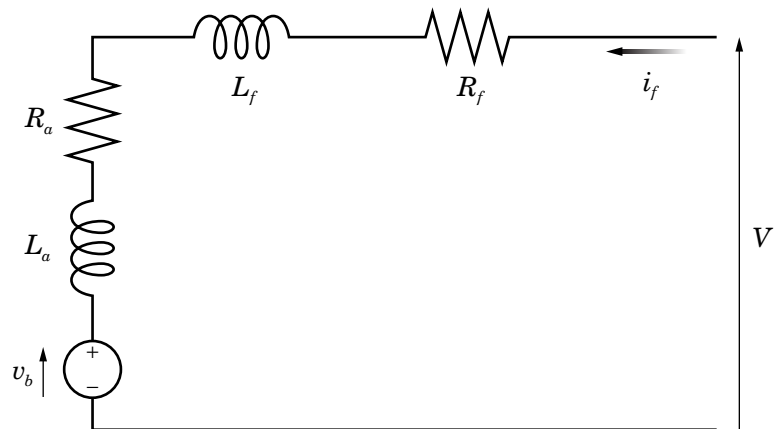

Where:

- R_a is the armature resistance.
- L_a is the armature inductance.
- R_f is the field winding resistance.
- L_f is the field winding inductance.

When you set the **Model parameterization** parameter to By equivalent circuit parameters, you specify the equivalent circuit parameters for this model. The Universal Motor block computes the motor torque as follows:

- 1 The magnetic field in the motor induces the following back emf v_b in the armature:

$$v_b = L_{af} i_f \omega$$

where L_{af} is a constant of proportionality and ω is the angular velocity.

- 2 The mechanical power is equal to the power reacted by the back emf:

$$P = v_b i_f = L_{af} i_f^2 \omega$$

- 3 The motor torque is:

$$T = P / \omega = L_{af} i_f^2$$

The torque-speed characteristic for the Shunt Motor block model is related to the parameters in the preceding figure. When you set the **Model parameterization** parameter to By DC rated power, rated speed & maximum torque or By DC rated power, rated speed & electrical power, the block solves for the equivalent circuit parameters as follows:

- 1 For the steady-state torque-speed relationship when using a DC supply, L has no effect.
- 2 Sum the voltages around the loop:

$$V = (R_f + R_a) i_f + v_b = (R_f + R_a + L_{af} \omega) i_f$$

Universal Motor

- 3 Solve the preceding equation for i_f and substitute this value into the equation for torque:

$$T = L_{af} \left(\frac{V}{R_f + R_a + L_{af} \omega} \right)^2$$

The block uses the rated speed and power to calculate the rated torque. The block uses the rated torque and rated speed values in the preceding equation plus the corresponding electrical power to determine values for $R_f + R_a$ and L_{af} .

When you set the **Model parameterization** parameter to By AC rated power, rated speed, current & electrical power, then the block must include the inductive terms L_a and L_f in the model. This requires information about the RMS rated current and voltage for the total inductance.

The block models motor inertia J and damping B for all values of the **Model parameterization** parameter. The output torque is:

$$T_{load} = L_{af} \left(\frac{V}{R_f + R_a + L_{af} \omega} \right)^2 - J\dot{\omega} - B\omega$$

The block produces a positive torque acting from the mechanical C to R ports.

Dialog Box and Parameters

Electrical Torque Tab

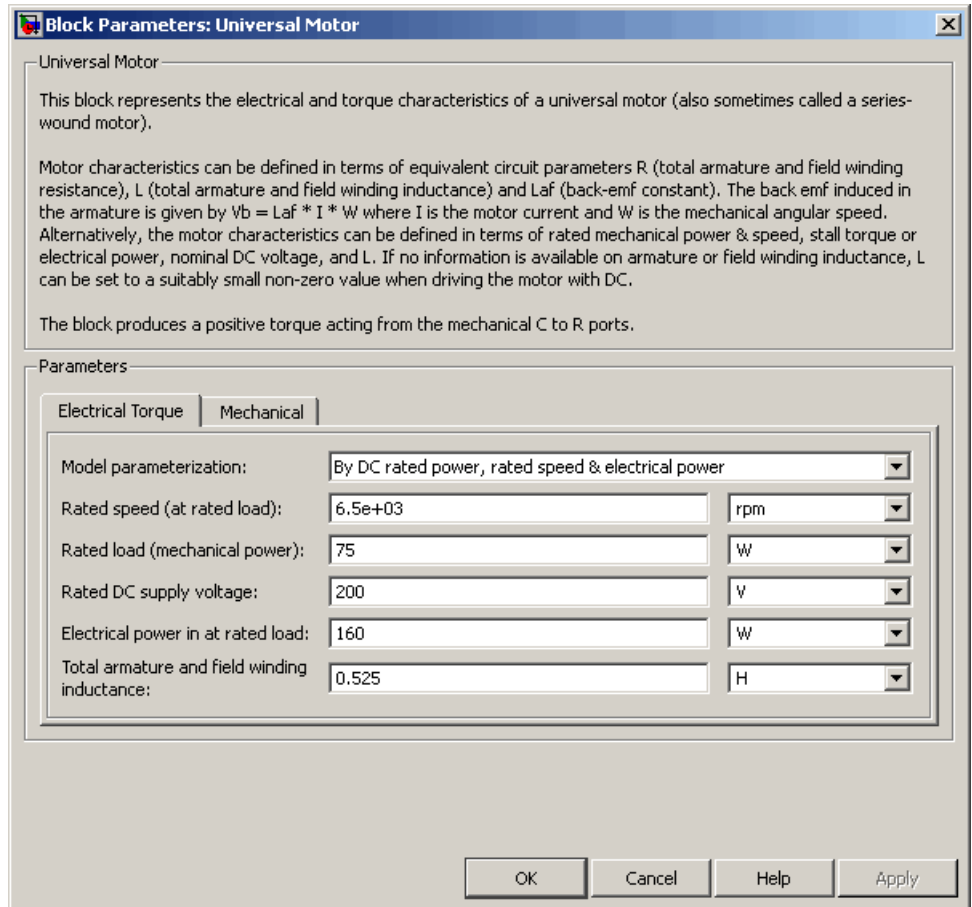

Model parameterization

Select one of the following methods for block parameterization:

- By equivalent circuit parameters — Provide electrical parameters for an equivalent circuit model of the motor.

- By DC rated power, rated speed & maximum torque — Provide DC power and speed parameters that the block converts to an equivalent circuit model of the motor. This is the default method.
- By DC rated power, rated speed & electrical power — Provide AC power and speed parameters that the block converts to an equivalent circuit model of the motor.
- By AC rated power, rated speed, current & electrical power — Provide AC power and speed parameters that the block converts to an equivalent circuit model of the motor.

Total armature and field winding resistance

Total resistance of the armature and field winding. This parameter is only visible when you select By equivalent circuit parameters for the **Model parameterization** parameter. The default value is 132.8 Ω .

Rated speed (at rated load)

Motor speed at the rated mechanical load. This parameter is only visible when you select By DC rated power, rated speed & maximum torque, By DC rated power, rated speed & electrical power, or By AC rated power, rated speed, current & electrical power for the **Model parameterization** parameter. The default value is 6.5e+03 rpm.

Rated load (mechanical power)

The mechanical load for which the motor is rated to operate. This parameter is only visible when you select By DC rated power, rated speed & maximum torque, By DC rated power, rated speed & electrical power, or By AC rated power, rated speed, current & electrical power for the **Model parameterization** parameter. The default value is 75 W.

Rated DC supply voltage

The DC voltage at which the motor is rated to operate. This parameter is only visible when you select By DC rated power, rated speed & maximum torque or By DC rated power, rated

speed & electrical power for the **Model parameterization** parameter. The default value is 200 V.

Electrical power in at rated load

The amount of electrical power the motor uses at the rated mechanical power. This parameter is only visible when you select By DC rated power, rated speed & electrical power or By AC rated power, rated speed, current & electrical power for the **Model parameterization** parameter. The default value is 160 W.

Maximum (starting) torque

Maximum torque the motor produces. This parameter is only visible when you select By DC rated power, rated speed & maximum torque for the **Model parameterization** parameter. The default value is 0.39 N*m.

Total armature and field winding inductance

Total inductance of the armature and field winding. If you do not have information about this inductance, set the value of this parameter to a small, nonzero number. This parameter is only visible when you select By equivalent circuit parameters, By DC rated power, rated speed & maximum torque, or By DC rated power, rated speed & electrical power for the **Model parameterization** parameter. The default value is 0.525 H.

Note You can set the **Total armature and field winding inductance** value to zero, but this only makes sense if you are driving the motor with a DC source.

RMS rated voltage

RMS supply voltage when the motor operates on AC power. This parameter is only visible when you select By AC rated power, rated speed, current & electrical power for the **Model parameterization** parameter. The default value is 240 V.

Universal Motor

RMS current at rated load

RMS current when the motor operates on AC power at the rated load. This parameter is only visible when you select By AC rated power, rated speed, current & electrical power for the **Model parameterization** parameter. The default value is 0.8 A.

AC frequency

Frequency of the AC supply voltage. This parameter is only visible when you select By AC rated power, rated speed, current & electrical power for the **Model parameterization** parameter. The default value is 50 Hz.

Mechanical Tab

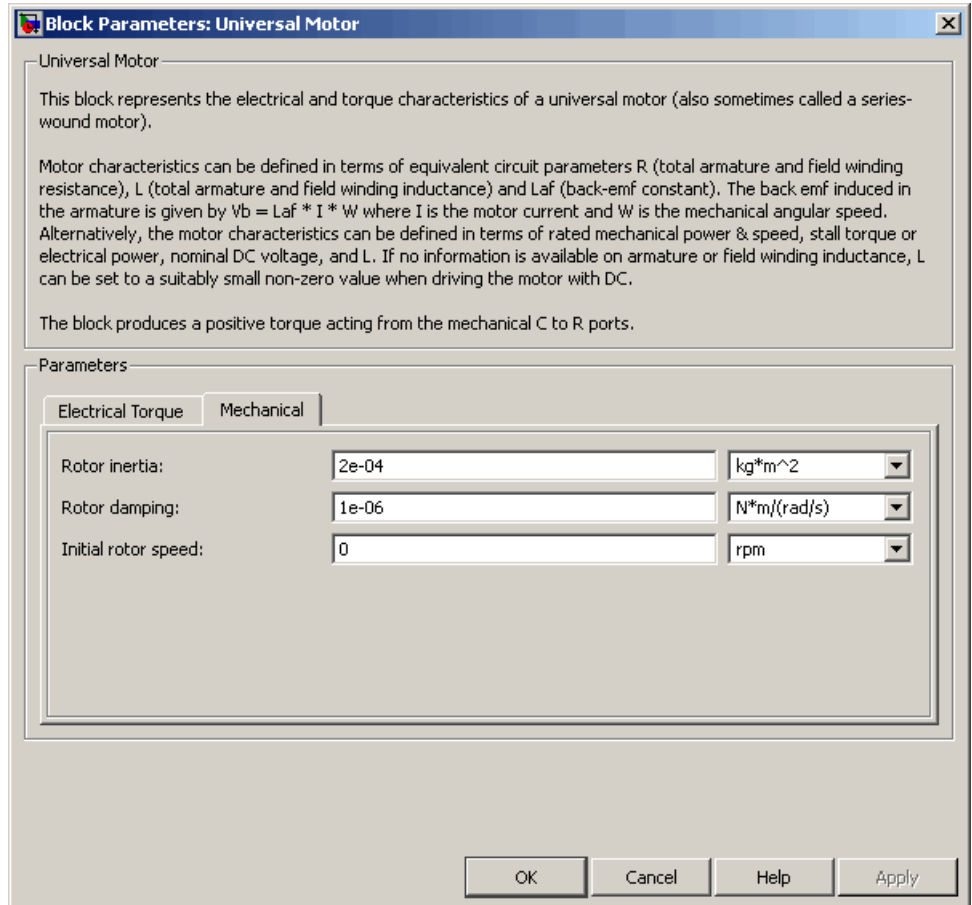

Rotor inertia

Rotor inertia. The default value is $2e-04 \text{ kg}\cdot\text{m}^2$. The value can be zero.

Universal Motor

Rotor damping

Rotor damping. The default value is $1e-06$ N*m/(rad/s). The value can be zero.

Initial rotor speed

Speed of the rotor at the start of the simulation. The default value is 0 rpm.

Ports

The block has the following ports:

+

Positive electrical port.

-

Negative electrical port.

C

Mechanical rotational conserving port.

R

Mechanical rotational conserving port.

References

[1] Bolton, W. *Mechatronics: Electronic Control Systems in Mechanical and Electrical Engineering* 3rd edition, Pearson Education, 2004.

See Also

DC Motor, Induction Motor, Servomotor, and Shunt Motor.

Purpose Model linear time-varying capacitor

Library Passive Devices

Description

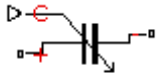

Variable Capacitor

The Variable Capacitor block represents a linear time-varying capacitor. The block provides two options for the relationship between the current i through the capacitor and the voltage v across the device when the capacitance at port C is C . The **Equation** parameter determines which of the following equations the block uses:

- $$i = \frac{dC}{dt} v + C \frac{dv}{dt}$$

Use the preceding equation when the capacitance is defined as the ratio of the charge Q to the steady-state voltage:

$$C(v) = \frac{Q(v)}{v}$$

- $$i = C \frac{dv}{dt}$$

Use the preceding equation when the capacitance is defined as the local gradient of the charge-voltage curve for a given voltage:

$$C(v) = \frac{dQ(v)}{dv}$$

The block includes a resistor in series with the variable capacitor. You can use this resistor to represent the total ohmic connection resistance of the capacitor. You may need to use this resistor to prevent numerical issues for some circuit topologies, such as where a Variable Capacitor block is connected in parallel with another capacitor block that does not have a series resistance.

Variable Capacitor

Dialog Box and Parameters

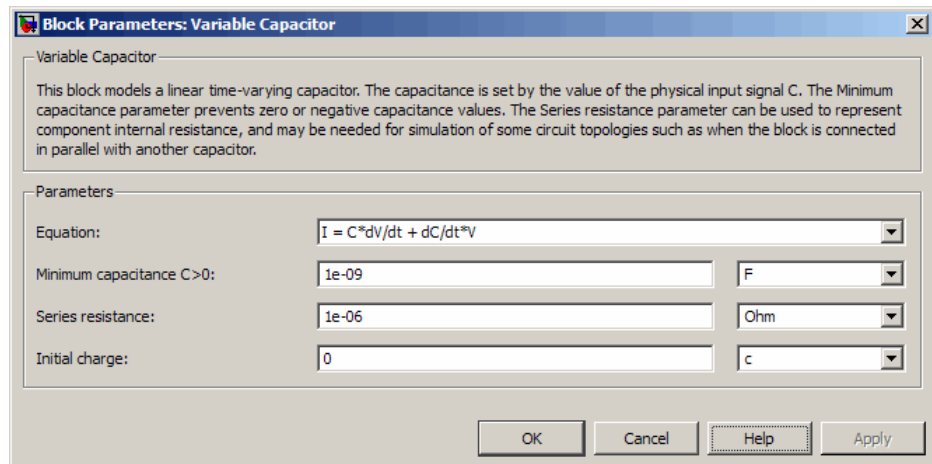

Equation

Select one of the following options for block capacitance:

- $I = C \cdot dV/dt + dC/dt \cdot V$ — This equation assumes the capacitance is defined as the ratio of the charge to the steady-state voltage. This option is the default.
- $I = C \cdot dV/dt$ — This equation assumes the capacitance is defined as the local gradient of the charge-voltage curve for a given voltage.

Minimum capacitance $C > 0$

The lower limit on the value of the signal at port C. This limit prevents the signal from reaching a value that has no physical meaning. The default value is 1e-09 F.

Series resistance

The value of the resistance placed in series with the variable capacitor. The default value is 1e-06 Ω .

Initial charge

The charge at the start of the simulation. This parameter is only visible when you select $I = C \cdot dV/dt + dC/dt \cdot V$ for the **Equation** parameter. The default value is 0 c.

Initial voltage

The output voltage at the start of the simulation. This parameter is only visible when you select $I = C \cdot dV/dt$ for the **Equation** parameter. The default value is 0 V.

Ports

The block has the following ports:

C

Capacitance. C must be finite and greater than zero.

+

Positive electrical port.

-

Negative electrical port.

See Also

Variable Inductor, Simscape Variable Resistor

Variable Inductor

Purpose Model linear time-varying inductor

Library Passive Devices

Description



Variable Inductor

The Variable Inductor block represents a linear time-varying inductor. The block provides two options for the relationship between the voltage v across the device and the current through the inductor i when the inductance at port L is L . The **Equation** parameter determines which of the following equations the block uses:

- $v = \frac{dL}{dt} i + L \frac{di}{dt}$

Use the preceding equation when the inductance is defined as the ratio of the magnetic flux Φ to the steady-state current:

$$L(i) = \frac{\Phi(i)}{i}$$

- $v = L \frac{di}{dt}$

Use the preceding equation when the inductance is defined as the local gradient of the flux-current curve for a given current:

$$L(i) = \frac{d\Phi(i)}{di}$$

The block includes a conductance in parallel with the variable inductor. You can use the conductor to represent the total insulation conductance of the inductor. You may need to use the conductor to prevent numerical issues for some circuit topologies, such as where a Variable Inductor block is connected in series with another inductor block that does not have a parallel conductance.

Dialog Box and Parameters

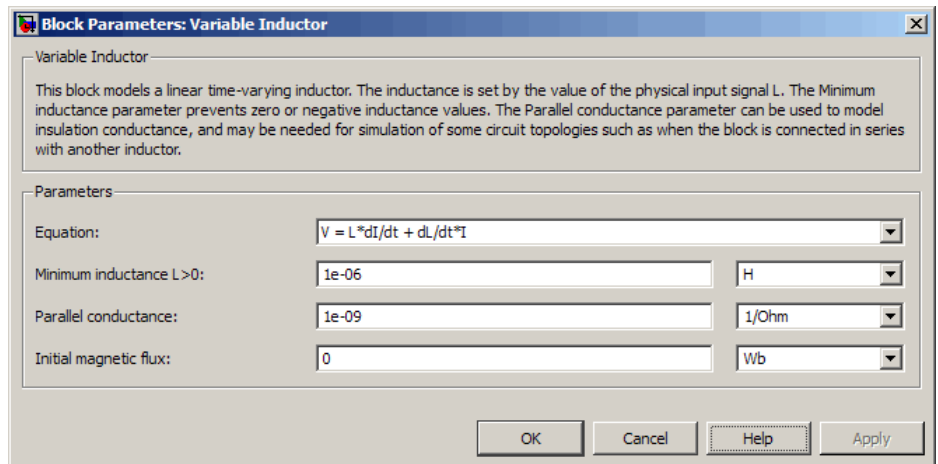

Equation

Select one of the following options for block inductance:

- $V = L \cdot dI/dt + dL/dt \cdot I$ — This equation assumes the inductance is defined as the ratio of the magnetic flux to the steady-state current. This option is the default.
- $V = L \cdot dI/dt$ — This equation assumes the inductance is defined as the local gradient of the flux-current curve for a given current.

Minimum inductance $L > 0$

The lower limit on the value of the signal at port L. This limit prevents the signal from reaching a value that has no physical meaning. The default value is $1e-06$ H.

Parallel conductance

The value of the conductance placed in parallel with the variable inductor. The default value is $1e-09$ $1/\Omega$.

Initial magnetic flux

The magnetic flux at the start of the simulation. This parameter is only visible when you select $V = L \cdot dI/dt + dL/dt \cdot I$ for the **Equation** parameter. The default value is 0 Wb.

Variable Inductor

Initial current

The output current at the start of the simulation. This parameter is only visible when you select $V = L \cdot dI/dt$ for the **Equation** parameter. The default value is 0 A.

Ports

The block has the following ports:

L

Inductance. L must be finite and greater than zero.

+

Positive electrical port.

-

Negative electrical port.

See Also

Variable Capacitor, Simscape Variable Resistor

Purpose Model voltage-controlled switch with hysteresis

Library Passive Devices

Description

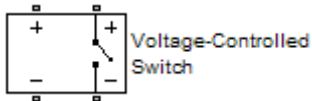

The Voltage-Controlled Switch block represents the electrical characteristics of a switch whose state is controlled by the voltage across the input ports (the *controlling voltage*):

- When the controlling voltage is greater than the sum of the **Threshold voltage, V_T** and **Hysteresis voltage, V_H** parameter values, the switch is closed and has a resistance equal to the **On resistance, R_{ON}** parameter value.
- When the controlling voltage is less than the **Threshold voltage, V_T** parameter value minus the **Hysteresis voltage, V_H** parameter value, the switch is open and has a resistance equal to the **Off resistance, R_{OFF}** parameter value.
- When the controlling voltage is greater than or less than the **Threshold voltage, V_T** parameter value by an amount less than or equal to the **Hysteresis voltage, V_H** parameter value, the voltage is in the *crossover region* and the state of the switch remains unchanged.

Basic Assumptions and Limitations

The block output resistance model is discontinuous during switching. The discontinuity might cause numerical issues. Try the following actions to resolve the issues:

- Set the **On resistance, R_{ON}** and **Off resistance, R_{OFF}** parameter values to keep the ratio R_{ON}/R_{OFF} as small as possible, and less than $1e+12$.
- Increase the **Hysteresis voltage, V_H** parameter value to reduce switch chatter.

Voltage-Controlled Switch

- Decrease the **Max step size** parameter value (in the Configuration Parameters block dialog box).

Note This increases the simulation time.

Dialog Box and Parameters

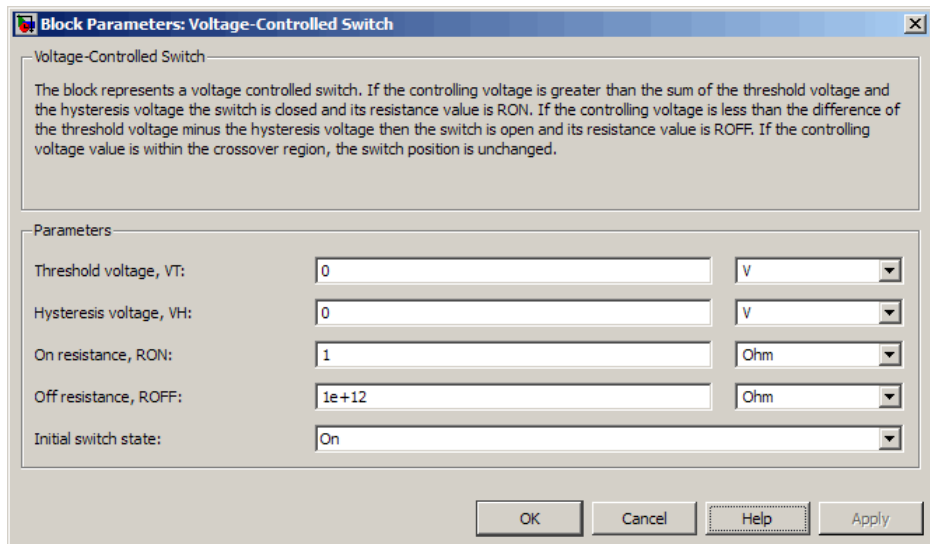

Threshold voltage, VT

The voltage above which the block interprets the controlling voltage as HIGH. The default value is 0 V.

Note The controlling voltage must differ from the threshold voltage by at least the **Hysteresis voltage, VH** parameter value to change the state of the switch.

Hysteresis voltage, VH

The amount by which the controlling voltage must exceed or fall below the **Threshold voltage, VT** parameter value to change the state of the switch. The default value is 0 V.

On resistance, RON

The resistance of the switch when it is closed. The default value is 1 Ω .

Off resistance, ROFF

The resistance of the switch when it is open. The default value is 1e+12 Ω .

Initial switch state

Select one of the following options for the state of the switch at the start of the simulation:

- **On** — The switch is initially closed and its resistance value is equal to the **On resistance, RON** parameter value. This is the default option.
- **Off** — The switch is initially open and its resistance value is equal to the **Off resistance, ROFF** parameter value.

Ports

The block has the following ports:

+

Positive electrical input and output ports.

-

Negative electrical input and output ports.

Voltage-Controlled Switch

Functions — Alphabetical List

netlist2sl

Purpose Convert SPICE netlist to library of Simulink blocks

Syntax
`modelname = netlist2sl(filename, newname)`
`modelname = netlist2sl(filename, options)`

Description `modelname = netlist2sl(filename, newname)` maps the circuit elements listed in the SPICE netlist file `filename` to a Simulink library or model `newname` that contains one or more blocks.

- `filename` is the full name of the netlist file; it can also include the path name.
- `newname` is the optional Simulink library or model name.

`netlist2sl` can import either subcircuit information or model card information into a block:

- When you import subcircuit data from a SPICE netlist, SimElectronics creates a block that represents the netlist.

The block dialog box for each imported block contains the following information:

- Subcircuit name
- Netlist file name
- Time the `netlist2sl` function created the block

You can look at a snapshot of the netlist the function used to create the block by clicking **Help** in the block dialog box.

- When you import model card data from a SPICE netlist, SimElectronics uses the data to populate the parameter values of the corresponding SPICE-compatible SimElectronics block.

SimElectronics only reads in device data. It ignores analysis statements such as `.TRAN`.

`modelName = netlist2sl(filename, options)` uses the information in the structure `options` to map the circuit elements in `filename` to a Simulink library. The structure has the following fields:

- **LibName** — A string that specifies the name of the Simulink library (or model) where `netlist2sl` puts the blocks.
- **ModelOnly** — A boolean value. True tells `netlist2sl` to generate a library that contains only blocks representing the model cards that appear in the SPICE file. False (the default value) tells `netlist2sl` to generate a library that contains all circuit information that appears in the SPICE file.
- **BlockDiagramType** — A string that indicates whether `netlist2sl` will generate a library or a model. Specifying 'library' causes the function to generate a library; specifying 'model' causes the function to generate a model without a library. 'library' and 'model' are the only two possible values. The default is 'library'.

The netlist file must define one or more SPICE subcircuits or model cards. To import a netlist that is not a subcircuit into the Simulink environment, add a subcircuit wrapper before using the `netlist2sl` function. “Example 2” on page 3-4 shows this procedure.

The output library has one block that represents the top-level subcircuit, and a block for each subcircuit that this subcircuit references. The block names match the subcircuit names, except that slashes (/) are replaced by underscores (_).

If the library already exists in the specified directory, `netlist2sl` adds new blocks to it. If a subcircuit name conflicts with an existing block name in the library or model, `netlist2sl` prompts you to either overwrite the existing block or rename the new block.

The model name, subcircuit name, instance name, and node name are all case insensitive.

When you create a library, you can drag and drop the blocks into any Simulink model. If you make any change to the library, Simulink applies the change to all instances of the affected block or blocks.

Note You cannot make changes directly to library blocks that you create with the `netlist2sl` function. To update the blocks, change the netlist and then run the `netlist2sl` function again.

Examples

Example 1

Suppose you have a netlist file, `SimpleDiode.cir` as follows:

```
.SUBCKT SimpleDiode 1 2
R1 1 3 100
D1 3 2 DMOD1
.model DMOD1 D(Is=1e-13 Rs=0.1)
.ENDS SimpleDiode
```

To import this netlist and create a library called `mylib` that contains a block called `SimpleDiode`, type the following at the MATLAB prompt:

```
netlist2sl('SimpleDiode.cir', 'mylib')
```

Example 2

Suppose you have a netlist that is not a subcircuit. To use the `netlist2sl` function, add a subcircuit wrapper to the netlist. Consider the following netlist file:

```
R1 1 3 100
D1 3 2 DMOD1
.model DMOD1 D(Is=1e-13 Rs=0.1)
```

If you want to probe nodes 1 and 2 in Simulink, add the subcircuit wrapper as follows:

```
.SUBCKT mydiode 1 2
R1 1 3 100
D1 3 2 DMOD1
.model DMOD1 D(Is=1e-13 Rs=0.1)
.ENDS mydiode
```

Then, apply the `netlist2sl` function to the modified netlist, as described in the preceding example.

Example 3

See the [Creating a Library Block from a Netlist](#) demo.

See Also

[“Importing SPICE Models Into a SimElectronics Library”](#)

B

Band-Limited Op-Amp block 2-2

C

CMOS AND block 2-6
CMOS Buffer block 2-10
CMOS NAND block 2-14
CMOS NOR block 2-18
CMOS NOT block 2-22
CMOS OR block 2-26
CMOS XOR block 2-30
Comparator block 2-34
Controlled PWM Voltage block 2-38
conversion
 netlist to Simulink library 3-2
Crystal block 2-41
Current-Controlled Switch block 2-47

D

DC Current Source block 2-50
DC Motor block 2-52
DC Voltage Source block 2-60
Diode block
 Diode 2-62
 Diode (SPICE) 2-76

E

Exponential Current Source block 2-92
Exponential Voltage Source block 2-95

F

Finite-Gain Op-Amp block 2-98
Fuse block 2-101

G

Generic Battery block 2-103

Generic Linear Actuator block 2-107
Generic Rotary Actuator block 2-113

H

H-Bridge block 2-119

I

Incremental Shaft Encoder block 2-125
Induction Motor block 2-128

L

Light-Emitting Diode block 2-140

N

N-Channel IGBT block 2-150
N-Channel JFET block 2-158
N-Channel MOSFET block 2-169
Negative Supply Rail block 2-177
netlist
 converting to Simulink library 3-2
netlist2s1 function 3-2
NJFET block 2-179
NMOS block 2-196
NPN Bipolar Transistor block 2-265
NPN block 2-237

O

Optocoupler block 2-273

P

P-Channel JFET block 2-281
P-Channel MOSFET block 2-292
Photodiode block 2-312
Piezo Linear Motor block 2-324
Piezo Rotary Motor block 2-334

Piezo Stack block 2-344
PJFET block 2-353
PMOS block 2-370
PNP Bipolar Transistor block 2-439
PNP block 2-411
Polynomial Current-Controlled Current Source block 2-300
Polynomial Current-Controlled Voltage Source block 2-306
Polynomial Voltage-Controlled Current Source block 2-465
Polynomial Voltage-Controlled Voltage Source block 2-471
Positive Supply Rail block 2-447
Proximity Sensor block 2-449
PS Sensor block 2-453
Pulse Current Source block 2-457
Pulse Voltage Source block 2-461
PWL Current Source block 2-477
PWL Voltage Source block 2-481

R

Relay block 2-484
Resistor block 2-487

S

S-R Latch block 2-493
Servomotor block 2-497
SFFM Current Source block 2-503
SFFM Voltage Source block 2-506
Shunt Motor block 2-509
Sinusoidal Current Source block 2-517

Sinusoidal Voltage Source block 2-520
Solar Cell block 2-523
Solenoid block 2-533
SPICE Environment Parameters block 2-540
Stepper Motor block 2-542
Stepper Motor Driver block 2-547
Strain Gauge block 2-550

T

Thermal Resistor block 2-559
Thermistor block 2-563
Thermocouple block 2-567
Three-Winding Mutual Inductor block 2-572
Timer block 2-552
Two-Input Polynomial Current-Controlled Current Source block 2-303
Two-Input Polynomial Current-Controlled Voltage Source block 2-309
Two-Input Polynomial Voltage-Controlled Current Source block 2-468
Two-Input Polynomial Voltage-Controlled Voltage Source block 2-474

U

Universal Motor block 2-576

V

Variable Capacitor block 2-585
Variable Inductor block 2-588
Voltage-Controlled Switch block 2-591